

AN INVESTIGATION OF DIAGONAL TENSIONS
IN REINFORCED CONCRETE BEAMS

A Thesis
Presented to
the Faculty of Graduate Studies and Research
The University of Manitoba

In Partial Fulfillment
of the Requirements for the Degree
Master of Science in Civil Engineering

by
King Hau Wu
July 1956

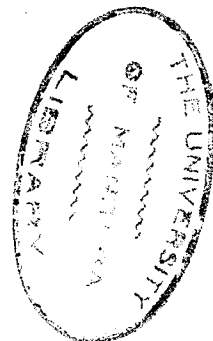

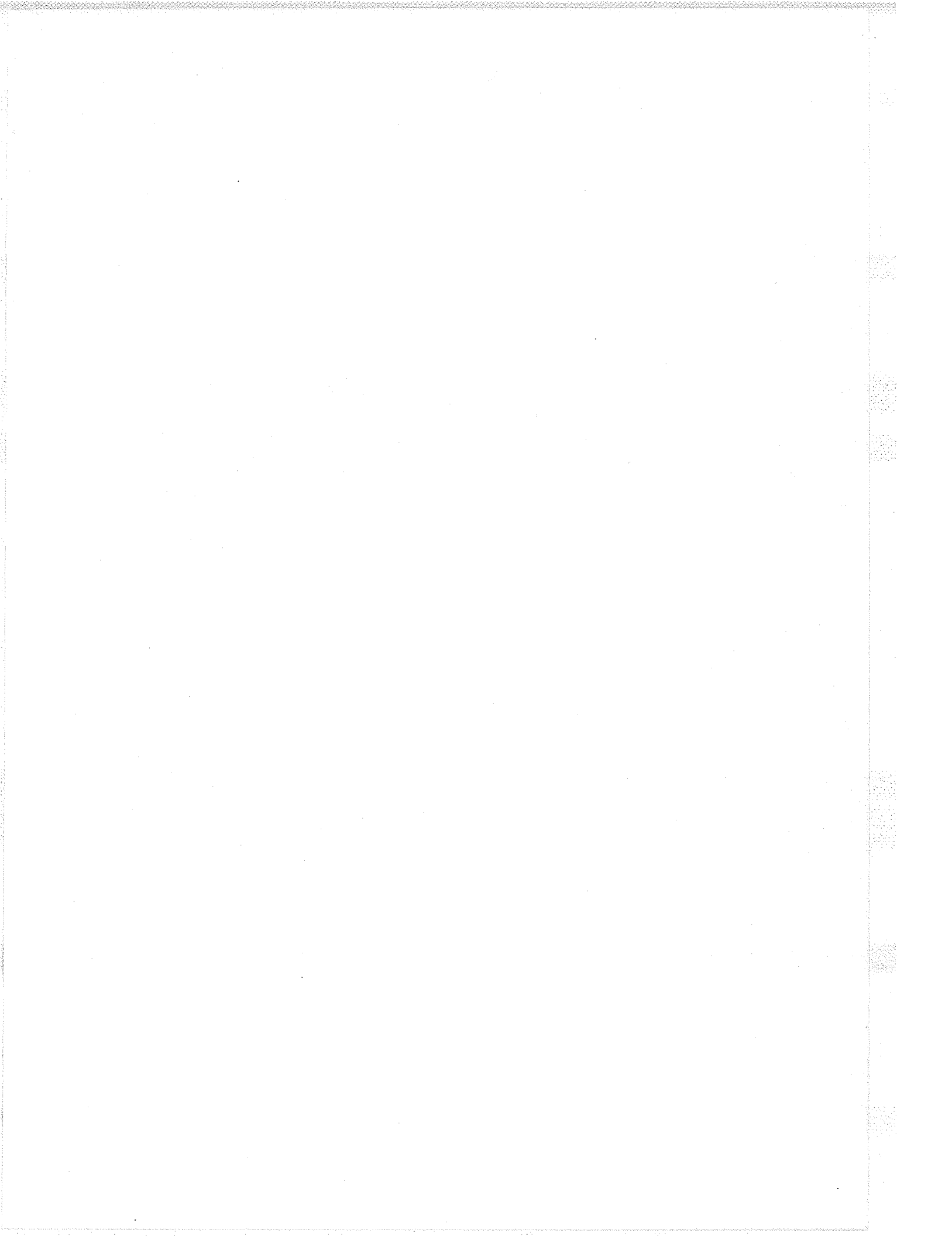

ACKNOWLEDGMENTS

I wish to acknowledge and to express my indebtedness to Prof. J. Hoogstraten who encouraged me to perform this investigation, suggested the basic principles, and gave valuable advice involved in it. He also kindly made the necessary arrangements with the National Research Council of Canada so that a fund of \$500.00 was granted for the expenses of the materials and labour in connection with this investigation. I appreciate the helpful suggestions and express my gratitude to Prof. C. M. Hovey who designed and supervised the fabrication of the concrete vibrators used in pouring the reinforced concrete beam specimens. To all the laboratory technicians who have helped me in this investigation I take this opportunity of expressing my obligation.

Grateful acknowledgments are made to Mr. G. W. Parkinson, Chief, Design Division of P.F.R.A., who was interested in this investigation and gave support for the accomplishment of this thesis. I am indebted to Mr. R. Bing-Wo, Engineer of P.F.R.A., who read the entire manuscript and reviewed it with me.

A vote of thanks is due D. Sameoto and B. Grainger, who traced all the figures in the thesis.

AN INVESTIGATION OF DIAGONAL TENSION
IN REINFORCED CONCRETE BEAMS

ABSTRACT

An investigation of diagonal tension of twenty-one reinforced concrete beams is presented in this thesis. Tests were carried out in three series of simply supported beams. A nest of rollers was inserted in each beam of Series I and II in order to eliminate the vertical shear stress of concrete in the compression zone. The beams of Series I were reinforced with tensile steel only while those of the other two series were provided with tensile and web reinforcement. The size of all beams was 8"x14"x6'-0". All beams except one were tested for three different positions of concentrated loads with a span of 5'-0". The compressive concrete strengths ranged from 1,800 to 5,500 psi. Deflections of the beams under load were measured and the crack patterns were observed and photographed. No strain gages were used to measure strains in the reinforcement.

All beams of Series I failed in an unexpected way other than diagonal tension failure. The test results indicate that the shear capacity of the beams of Series II seems to be affected by web and tensile reinforcement only and independent of concrete strength and shear span. The shear resistances contributed by concrete, web and tensile reinforcement in beams of Series III have been evaluated in the analysis. Due to the insufficient

number of beams tested, only a tentative ultimate shear equation was developed for computing shear capacity of reinforced concrete beams. Further, the application of the equation may be limited to beams similar to those of Series III and its accuracy will depend on the correctness of the estimation of the effective stirrups.

King Hau Wu

TABLE OF CONTENTS

CHAPTER		Page
I	INTRODUCTION	1
II	EARLY DEVELOPMENT OF SHEAR AND DIAGONAL TENSION IN REINFORCED CONCRETE BEAMS	3
	Early Development in Europe	3
	Early Development in the United States	4
III	SHEAR, BOND, AND DIAGONAL TENSION	6
	Shearing Stresses	6
	Bond Stresses	9
	Diagonal Tension in Plain Concrete Beams	9
	Diagonal Tension in Reinforced Concrete Beams	12
IV	REVIEW OF THE CURRENT INVESTIGATIONS OF SHEARING STRENGTH IN REINFORCED CONCRETE BEAMS	15
	The Investigation by Oreste Moretto	15
	The Investigation by Arthur P. Clark	16
	The Investigation by Moody - Viest	16
	Discussion of the Current Investigations	17
V	THEORIES AND METHODS OF EVALUATION OF THREE IMPORTANT FACTORS IN DIAGONAL TENSION STRENGTH	18
	Method of Evaluating the Shearing Strength of the Longitudinal Tension Steel	19

CHAPTER		Page
	Method of Evaluating the Shearing Strengths Developed by Tension in Vertical Stirrups and Uncracked Concrete	20
	Redistribution of Internal Stresses	22
VI	SPECIMENS, EQUIPMENT, AND TEST PROCEDURES	24
	Beams of Series I	24
	Beams of Series II	24
	Beams of Series III	25
	Types of Loading	25
	Designation of Beams	25
	Design of Beams	27
	Materials	27
	Fabrication of Specimens	29
	Test Equipment and Procedure	34
VII	TEST RESULTS	35
	Behavior prior to Formation of Diagonal Tension Cracks	68
	Initial Diagonal Tension Cracking	68
	Behavior after the Formation of Diagonal Tension Cracks	69
VIII	ANALYSIS OF TEST RESULTS	74
	Study of Failure for Beams in Series I	74
	Derivation of Ultimate Shear Equation for Beams of Series II	76

CHAPTER		Page
	Derivation of Ultimate Shear Equation for Beams of Series III	82
IX	SUMMARY, DISCUSSIONS, AND RECOMMENDATIONS . . .	91
	Summary	91
	Discussions	92
	Recommendations	94
	BIBLIOGRAPHY	96

LIST OF TABLES

TABLE		Page
1	Details of Specimens of Series I	26
2	Details of Specimens of Series II and III	26
3	Physical Properties of Steel Bars	28
4	Ratio of Concrete Mixtures	28
5	Cylinder Tests	36
6	Tests of No. 3 Steel Bars	37
7	Results of Tests of Three Different Series of Beam Specimens	38
8	Evaluation of Shear Forces Taken by Tension Steel For Beams of Series II	81
9	Comparison of Actual and Computed Shear Loads For Beams of Series II	81
10	Computation for the Derivation of Ultimate Equation for those Beams of Series III which Failed in Diagonal Tension	87
11	Comparison of Nominal and Calculated Ultimate Shearing Stresses for those Beams of Series III which Failed in Diagonal Tension	87

LIST OF FIGURES

FIGURE		Page
1.	Element of Beam Subjected to Shearing Stress and Its Shearing Stress Diagram	7
2.	Stress Trajectories of Plain and Reinforced Concrete Beams	11
3.	A Beam of Series I with Hypothetical Crack . . .	21
3A.	The Free Body Diagram of the Beam in Figure 3 .	21
4.	A Beam of Series II with Hypothetical Crack . .	21
4A.	The Free Body Diagram of the Beam in Figure 4 .	21
5.	A Beam of Series III with Hypothetical Crack . .	21
5A.	The Free Body Diagram of the Beam in Figure 5 .	21
6.	Reinforcement of Beams of Series II and III Subjected to "B" and "C" Loadings	30
7.	Reinforcement of Beams of Series II and III Subjected to "A" Loading	30
8.	Equipment for Fabricating Concrete Beams and Cylinders	31
9.	Concrete Beams and Cylinders Piled up in the Laboratory before Tests	31
10.	Sketch showing Testing Arrangement for Beam Specimens	33
11.	Picture showing Testing Arrangement for Beam Specimens	33
12.	Load Deflection Curve for Beam IIIA1	39

FIGURE		Page
13.	Load Deflection Curves for Beams IA1 and IIA1 .	40
14.	Load Deflection Curves for Beams IA2, IIA2, and IIIA2	41
15.	Load Deflection Curves for Beams IB3, IIB3, and IIIB3	42
16.	Load Deflection Curves for Beams IB4, IIB4, and IIIB4	43
17.	Load Deflection Curves for Beams IB5, IIB5, and IIIB5	44
18.	Load Deflection Curves for Beams IC6, IIC6, and IIIC6	45
19.	Load Deflection Curves for Beams IC7, IIC7, and IIIC7	46
20.	Detail and Crack Patterns of Beam IA1	47
21.	Detail and Crack Patterns of Beam IA2	48
22.	Detail and Crack Patterns of Beam IB3	49
23.	Detail and Crack Patterns of Beam IB4	50
24.	Detail and Crack Patterns of Beam IB5	51
25.	Detail and Crack Patterns of Beam IC6	52
26.	Detail and Crack Patterns of Beam IC7	53
27.	Detail and Crack Patterns of Beam IIA1	54
28.	Detail and Crack Patterns of Beam IIA2	55
29.	Detail and Crack Patterns of Beam IIB3	56
30.	Detail and Crack Patterns of Beam IIB4	57
31.	Detail and Crack Patterns of Beam IIB5	58

FIGURE		Page
32.	Detail and Crack Patterns of Beam IIC6	59
33.	Detail and Crack Patterns of Beam IIC7	60
34.	Detail and Crack Patterns of Beam IIIA1	61
35.	Detail and Crack Patterns of Beam IIIA2	62
36.	Detail and Crack Patterns of Beam IIIB3	63
37.	Detail and Crack Patterns of Beam IIIB4	64
38.	Detail and Crack Patterns of Beam IIIB5	65
39.	Detail and Crack Patterns of Beam IIIC6	66
40.	Detail and Crack Patterns of Beam IIIC7	67
41.	Broken Parts of Beam IB3 Showing Typical View of Beams of Series I after Failure	75
42.	Typical Failure for Beams of Series I	75
42A.	Free Body Diagram for Beams of Series I after the Formation of Diagonal Crack	75
43.	Graph Showing Relation of Areas and Shear Forces of Tensile Steel for Beams of Series II	83
44.	Comparison of Actual and Computed Ultimate Shear Loads for Beams of Series II	84
45.	Relation between Nominal Shearing Stresses Contributed by Concrete in Compression Zone and $f'_c (d/a)$	88
46.	Comparison of Nominal and Calculated Ultimate Shearing Stresses for Beams of Series III Failing in Diagonal Tension	89
47.	Recommended Beams in Place of the Beams of Series I for Further Investigation	95

NOTATION

The following notation is used throughout this thesis.

- A_s = area of tension reinforcement
 A_v = area of web reinforcement
 a = shear span which is the distance between a support and the nearest interior load point
 α = angle of web reinforcement to a horizontal line
 b = width of a rectangular beam
 C and C' = resultants of compressive stresses in concrete
 C_1 , C_2 , and C_3 = resultants of compressive stresses in concrete at diagonal tension failure for beams of Series I, II, and III respectively
 ΔC = increment of compressive force
 c = principal compressive stress
 d = effective depth of tension reinforcement
 f = horizontal fiber stress
 f_s = stress in tension reinforcement at failure
 f_v = critical tensile stress of web reinforcement
 f_y = yield point stress of reinforcement
 f'_c = compressive strength of 6 x 12 in. concrete control cylinders
 I = moment of inertia of cross section about neutral axis
 jd = internal moment arm
 K = $(\sin \alpha + \cos \alpha) \sin \alpha$ and $K = 1$ for beams with vertical stirrups
 k_1 and k_3 = coefficients
 M_s = moment at the critical section of a beam at shear failure

- m = number of stirrups across a diagonal crack
 O = perimeter of reinforcing bar
 P_I, P_{II} and P_{III} = ultimate loads at diagonal tension failure in beams of Series I, II, and III respectively
 P_c = initial cracking load
 P_u = ultimate load at diagonal tension failure
 P = ratio of A_s/bd
 Q = statical moment about neutral axis of that portion of cross section beyond the layer containing a particle
 q = moment arm between reaction of beam and resultant of tension for beams of Series I
 R_I, R_{II} and R_{III} = reactions at diagonal tension failure in beams of Series I, II, and III respectively
 r = ratio of A_v/b_s
 S = shearing force along the plane of tension reinforcement
 S_c = shearing force of uncracked concrete
 S_t = shearing force of tension reinforcement
 s = spacing of stirrup
 s_t = unit shearing stress of tension reinforcement
 T and T' = tension forces in tension reinforcement
 $T_1, T_2,$ and T_3 = tension forces in tension reinforcement at diagonal tension failure for beams of Series I, II, and III respectively
 T_v = total tension force in web reinforcement crossing a diagonal tension crack
 ΔT = increment of tension in tensile reinforcement
 t = principal tensile stress or diagonal tension

u = bond stress of reinforcement

V = shearing force

V_I and V_{II} = shearing forces at diagonal tension failure for beams
of Series I and II respectively

v = nominal shearing stress = $\frac{V}{bjd}$

v_I and v_{II} = $\frac{V_I}{bjd}$ and $\frac{V_{II}}{bjd}$ respectively

v_{II} = nominal shearing stress at diagonal tension failure

\bar{x} = longitudinal distance defining the location of T_v

ϕ = inclination of diagonal tension

CHAPTER I
INTRODUCTION

There are many different modes of failure of reinforced concrete beams. Their cause of failure may be due to either bending or shear exceeding its resisting capacity. There have been comparatively more research work and more theories developed in ultimate flexural strength of beams than those in ultimate shearing strength. Therefore the flexural stresses are better understood and the design criterias for flexure in building codes are generally safe. However, due to inadequate information from laboratories, building codes may not have sufficiently stringent requirements for beams subjected to shear. This may be a factor leading to inadequate structural designs and consequent failure.

On 17 August 1955, one span of a rigid frame warehouse at Wilkins Air Force Base, Shelby, U.S.A. collapsed. Serious cracks opened in several other warehouses of the same design. Various studies about this matter urged The American Concrete Institute to revise the diagonal tension requirement of the 1951 ACI Building code. Increased web reinforcement for diagonal tension and specified amounts of anchorage of negative tension reinforcement have been added in the Building Code Requirements for Reinforced Concrete (ACI 318-56) published in the ACI Journal, May 1956.

Because of the importance of the shearing stresses in reinforced concrete beams more investigations should be devoted to

this field. The purpose of this study was to investigate the contribution of longitudinal tensile reinforcement, web reinforcement, and concrete strength to the ultimate shearing strength of reinforced concrete beams.

In this investigation only simply supported reinforced concrete beams were tested and the web reinforcement was limited to one type of two-legged vertical stirrups. The nominal concrete strengths varied from 2,000 psi to 5,000 psi. The ratios of the area of the tensile steel to the effective cross sectional area of the concrete varied from 0.0256 to 0.0412. The beams were rather heavily reinforced in tension steel since flexural failure was to be avoided in this investigation.

CHAPTER II
EARLY DEVELOPMENT OF SHEAR AND DIAGONAL TENSION
IN REINFORCED CONCRETE BEAMS

It is of interest to describe the early development of shear and diagonal tension in reinforced concrete beams. Some of the early correct theories developed in this field were rejected and soon forgotten by others until they were found again and verified to be right. The early developments were mainly in Europe and in the United States.

Early development in Europe In 1899, W. Ritter presented the first published study of web reinforcement. He suggested Eq. (1) be used in designing vertical stirrups based on truss analogy.

$$v = \frac{A_v f_v j d}{s} \quad (1)$$

However it was not accepted because the basic concepts were not understood by some other well-known engineers of that time.

E. Mörsch, a great German engineer, established the first laboratory for testing shear in reinforced concrete beams. In 1902 he presented a pattern of diagonal cracks which indicated diagonal tension as the cause of shear failures in reinforced concrete beams.

Still some engineers in Europe did not agree with Mörsch. They believed that horizontal shear is the cause of shearing failures in reinforced concrete beams. Even an authority of that day considered the resistance of stirrups to be derived from their horizontal shearing strength instead of tensile strength.

In 1907 Mörsch presented an important paper pertaining to further developments in diagonal tension. He pointed out the following items:

(a) Diagonal tension is the cause of shear failures in reinforced concrete beams according to a study of stress trajectories.

(b) The nominal shearing stress should be used as a measure of diagonal tension and it is computed by Eq. (2)

$$v = \frac{V}{bjd} \quad (2)$$

(c) Stirrups act in tension but not in horizontal shear.

(d) Failure of reinforced concrete beams in diagonal tension was explained by means of redistribution of internal stresses after the formation of diagonal tension crack. This will be discussed in detail in Chapter V. The final failure of the beam may be caused by a crushing failure in the compression zone or by a bond failure in tensile reinforcement. He supported Eq. (1) by assuming that the vertical shear is entirely taken by stirrups and diagonal crack inclined at an angle of 45 degrees.

Eq. (2) is still employed in current design as a measure of diagonal tension. Modified Eq. (1) is also used in design of vertical stirrups in the ACI Building Code. The total vertical shear V in Eq. (2) has changed to V^* which is the difference of the total vertical shear and the allowable vertical shear resisted by concrete.

Early development in the United States In the United States diagonal tension in reinforced concrete beams were reported by E. A. Moritz and A. N. Talbot in 1906. M. O. Withey introduced Eq. (1) into

the American concrete literature. He indicated that in addition to the tension in the vertical stirrups, the uncracked concrete in the compression zone, and a possible dowel action of the longitudinal tensile reinforcement may carry part of the shear. In 1909 Talbot reported a study of web stresses from tests of 188 reinforced concrete beams.

By 1910, diagonal tension was well established as the cause of the shear failures in normal reinforced concrete beams in Europe and the United States. The theories concerning shear, bond and diagonal tension will be presented in Chapter III.

CHAPTER III

SHEAR, BOND, AND DIAGONAL TENSION

This chapter contains the derivations of formulas for nominal shearing and bond stresses, the distinction of shearing stresses from diagonal tension, and the explanation of diagonal tension cracks by means of stress trajectories in reinforced concrete beams. It was felt that a review of these would lead to a better understanding of the investigation. The subsequent paragraphs of this chapter are devoted to this purpose.

Shearing Stresses These stresses are those which tend to make one vertical or horizontal plane of concrete sliding along its adjacent plane. For homogeneous or plain concrete beams, unit shearing stress can be computed by Eq. (3) from principles of mechanics

$$v = \frac{VQ}{Ib} \quad (3)$$

Reinforced concrete beams are not homogeneous. When they are subjected to shearing forces, they behave in quite a different manner from that of plain concrete beams. It is usually assumed that no longitudinal tension is carried by the concrete and that there is no slipping between concrete and steel in calculating shearing and bond stresses.

Consider an element with a short length dx of the beam as a free body in Fig. 1 (a). The forces acting on this element are the resultants of compressive forces C and C' , the tensile forces T and T' , and the vertical shear V . The increment of tension, ΔT , tends to pull

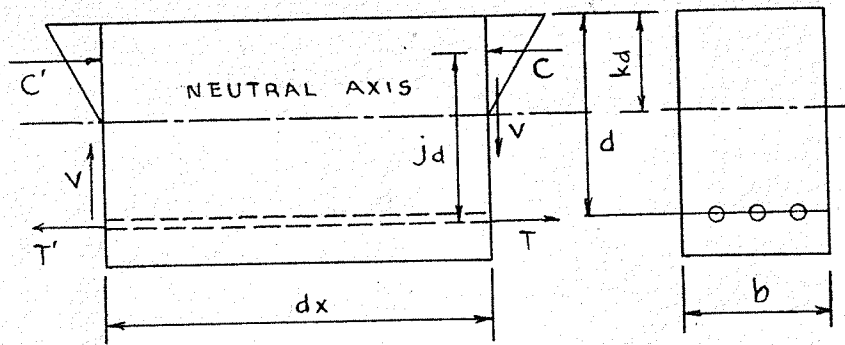

Fig. 1 (a)



Fig. 1 (d)

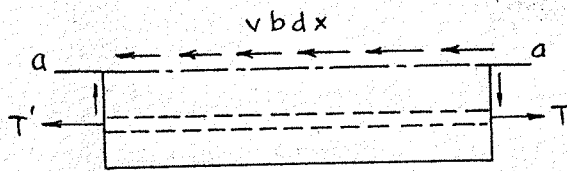

Fig. 1 (b)

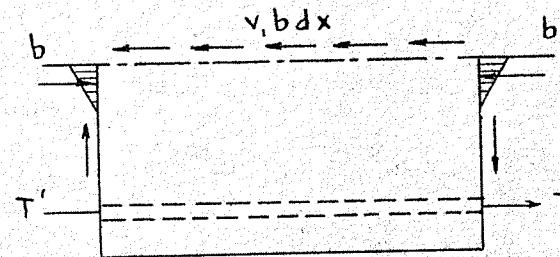

Fig. 1 (c)

Figure 1

Element of beam subjected to shearing stress
and its shearing stress diagram.

the lower part of the element to the right while the increment of compression, ΔC , tends to push the upper part to the left. However, these external forces must be in equilibrium. Therefore, the increment of tension, ΔT , in the steel can be computed by taking moments at A.

$$\begin{aligned} \Sigma M_A = 0 \quad \Delta T \cdot jd &= Vdx \\ \therefore \Delta T &= \frac{V dx}{jd} \end{aligned} \quad (4)$$

The free body in Fig. 1 (b) is a portion of the element of Fig. 1 (a) cut by the horizontal section line a - a between the neutral axis and the tension steel. The increment of tension, ΔT , is resisted by the horizontal shearing force $v b dx$ along the section line a-a.

Equilibrium gives

$$\Delta T = v b d x \quad (5)$$

$$\text{From Esq. (4) and (5) } v = \frac{V}{b j d} \quad (2)$$

Eq. (2) is the equation of nominal shearing stress which gives a constant unit shearing stress between the tension reinforcement and the neutral axis. This equation is applicable to reinforced concrete beams subjected to moment and shear only. If a direct thrust or a direct tension also acts upon the element, some modification to the equation is necessary.

The shearing stress in the compression zone is smaller than the nominal shearing stress because the increment of compression exists in the free body diagram. Fig. 1 (c) shows a portion of the element of Fig. 1 (a) cut by a horizontal line b-b above the neutral axis. The shearing stress at any point in the compression zone of reinforced concrete beams may be computed by Eq. (3). A typical distribution of unit

shearing stress in a cross section of a reinforced concrete beam is shown in Fig. 1 (d). Shearing stresses in compression zone are usually not calculated, only the nominal shearing stress is significant in designs and studies of reinforced concrete beams.

Bond Stresses Bond stress is the intensity of an adhesive force between the surfaces of the steel reinforcement and the concrete. The transmission of the increment in total tensile stress to the shearing stress is dependant on the bond between the concrete and the steel. Therefore in Fig. 1 (a) the bond force $u (\Sigma 0) (dx)$ must be equal to the increment of tension, ΔT .

$$u (\Sigma 0) dx = \Delta T \quad (6)$$

$$\text{Combine Eqs. (4) and (6)} \quad u (\Sigma 0) (dx) = \frac{V dx}{jd}$$

$$u = \frac{V}{\Sigma o jd} \quad (7)$$

Eq. (7) is the nominal bond stress in reinforced concrete beams. In this investigation, failure of reinforced concrete beams due to bond failure was very undesirable. Hence special anchorage with washers welded at the ends of steel bars was provided to prevent beams failing in this mode, although it was realized that with modern deformed bars bond failures are not probable in simple beams of normal proportion.

Diagonal tension in Plain Concrete Beams Diagonal tension is the inclined principal tension owing to the action of fiber stress and the horizontal and vertical shearing stresses in concrete beams. The simply supported plain concrete beam in Fig. 2 (a) is subjected to uniform loads which cause shearing and bending stresses. Let

Figs. 2 (b) and (c) represent infinitely small cubes of concrete below and above the neutral axis respectively. The forces acting on these elements are the vertical and horizontal shearing stresses of equal intensity v and the horizontal fiber stress f normal to the vertical axis. The horizontal stress is in tension or in compression depending on whether it is below or above the neutral axis. Because of the combined effect of these stresses, principal stresses result as shown in Figs. 2 (b) and 2 (c). The principal tensile stress t and the principal compressive stress c can be computed by Eqs. (8) and (9). The principal tensile stress in concrete is known as diagonal tension.

$$t = \frac{f}{2} + \sqrt{\frac{f^2}{4} + v^2} \quad (8)$$

$$c = \frac{f}{2} - \sqrt{\frac{f^2}{4} + v^2} \quad (9)$$

Where f is positive for a tensile fiber stress, and negative for a compressive fiber stress. The directions of principal stresses are given in Eq. (10)

$$\tan \phi = -\frac{2v}{f} \quad (10)$$

Two values of ϕ , differing by 90 deg., will satisfy Eq. (10). This corresponds with the fact that principal stresses occur orthogonally at each point. According to a principle of mechanics the principal tensile stress will always lie within the principal 45 deg. angle which is the angle subtended by the algebraically greater normal stress and the shear diagonal. Thus, the inclination of diagonal tension of any particle below the neutral axis is less

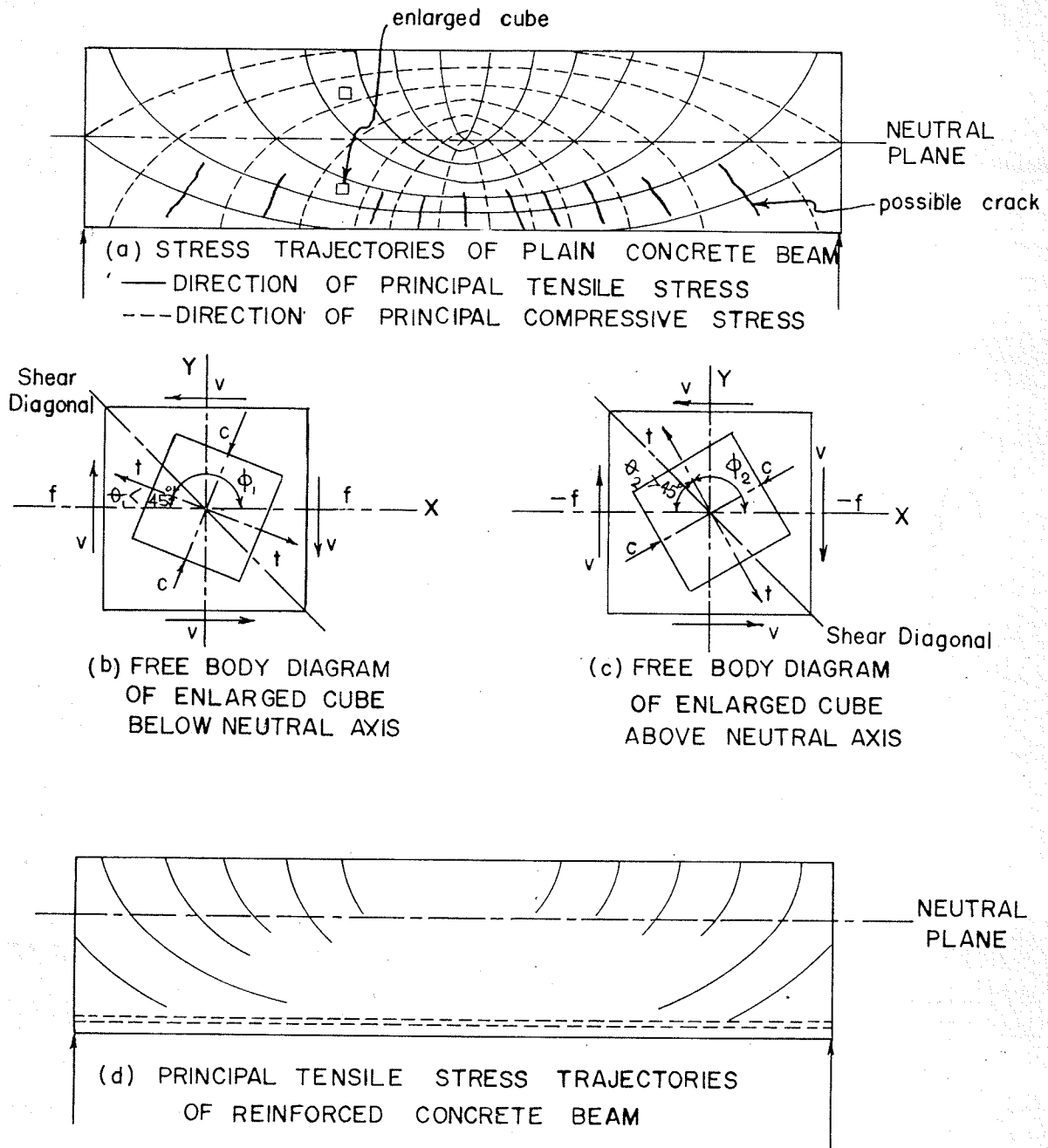

FIGURE 2
 STRESS TRAJECTORIES OF PLAIN & REINFORCED
 CONCRETE BEAMS

than 45 deg. and that above the neutral axis is more than 45 deg. as shown in Figs. 2 (b) and (c). For any particle along the neutral axis the direction of its diagonal tension must be 45 deg. with the horizontal since the fiber stress is equal to zero in Eq. (10). With the use of Eq. (10) two families of stress trajectories at right angles to each other can be drawn for the whole beam. Stress trajectories are those curves whose tangents and normals at all points on the curves are the directions of principal stresses. In Fig. 2 (a) the family of solid curves represents the directions of the diagonal tensions and the family of the dotted curves indicates the directions of the principal compressive stresses.

Because concrete is strong in compression and weak in tension, plain concrete beams may fail suddenly without warning due to diagonal tension. Careful attention should be given particularly to diagonal tension. The first term on the left hand side of Eq. (8) will become negative for compressive fiber stress, so it is obvious that in any section of a simply supported homogeneous beam the intensities of diagonal tensions below the neutral axis are much larger than those above the neutral axis. Therefore probable cracks would usually occur below the neutral axis and in the directions normal to the principal tensile stress trajectories as shown in Fig. 1 (a). The cracks normal or nearly normal to the horizontal edge of the beam are tension cracks while the inclined cracks are called diagonal tension cracks.

Diagonal tension in reinforced concrete beams Due to the concentration of tension in steel reinforcement the magnitude of tensile

fiber stresses are quite uncertain in reinforced concrete beams. Although it is impossible to compute diagonal tension accurately by Eqs. (8) and (10), yet an approximate picture of stress trajectories may be obtained. Fig. 2 (d) shows the approximate principal tensile stress trajectories for a uniformly loaded reinforced concrete beam without web reinforcement. These curves are somewhat similar to those in the plain concrete beam in Fig. 2 (a). However, the stress trajectories in the central portion of the beam below the neutral axis are quite indeterminate and therefore are not shown in the figure. All the curves cross the neutral axis at nearly 45 deg. and approach the top edge of the beam at 90 deg. The possible cracks are also shown in the figure. In order to simplify the conceptions of these inclined stresses and for convenience in designing web reinforcement, the nominal shearing stress is arbitrarily used as a measure of the diagonal tension in common practice. It must be realized that the shearing stress is only one of the two factors affecting the diagonal tension and there is no definite relation between the diagonal tension and the shearing stress alone. For instance, the shearing stresses in a simple beam and an identical restrained beam with the same loading condition may be equal, yet the diagonal tensions at the supports of the simple beam may be much smaller than those of the restrained beam because there is no fiber stress existing at the supports of the simple beam.

Since theoretical analysis can give only very rough estimation as to diagonal tension of reinforced concrete beams, it is necessary to conduct extensive experimental tests to determine the

shearing strengths of the beams having various influencing factors. The failure by diagonal tension may be presented if the shearing stress is kept below the ultimate by a certain factor of safety of the order of two or three.

CHAPTER IV

REVIEW OF THE CURRENT INVESTIGATIONS OF SHEARING

STRENGTH IN REINFORCED CONCRETE BEAMS

It was considered beneficial in the preparation of this study to make a review of current investigations being carried on by others on the shearing strength of reinforced concrete beams.

This chapter is devoted to reviewing these studies. Current studies include the papers presented by Oreste Moretto in 1945, by Arthur P. Clark in 1951, and by Moody-Viest in 1955. The beams tested by Moretto and Clark were simply supported beams while those tested by Moody-Viest consisted of both simple and restrained beams. In their tests, the strains in concrete and steel reinforcement were measured by electric strain gages to determine the corresponding stresses developed under testing. The deflections of beams were also recorded and the cracks were observed. A brief description of their individual studies will be presented in the following paragraphs.

The investigation by Oreste Moretto In his paper forty four reinforced concrete beams with stirrups welded to the longitudinal reinforcement were presented. The tests were made on simple beams and loaded at third points. It was concluded that a beam with welded stirrups might increase resistance to diagonal tension by 20 per cent over one with similar loose stirrups. Finally Eq. (11) for predicting the ultimate load on the basis of ultimate nominal shearing stress was proposed, taking into account the effect of the web reinforcement, the strength of concrete, and the amount of the tensile longitudinal reinforcement.

$$v_u = K_r f_y + 0.10 f'_c + 5,000p \quad (11)$$

where $K = (\sin \lambda + \cos \lambda) \cdot \sin \lambda$ and $K = 1$ for beams with vertical stirrups.

The investigation by Arthur P. Clark Clark's tests included simple beams with two different cross sections, four different spans, five different loadings and concrete strengths varying from 2,000 to 6,900 psi. He believed that in addition to the factors considered by Moretto the ratio of shear span to the effective depth would also affect the ultimate shearing strength of reinforced concrete. Eq. (12) is an empirical equation suggested by Clark.

$$v_u = 2,500 \sqrt{f'_c} + 0.12 f'_c \cdot \frac{d}{a} + 7,000 p \quad (12)$$

The investigation by Moody-Viest From the studies of 136 simple and restrained rectangular beams with and without web reinforcement, general equations applicable to both kinds of beams for predicting the initial diagonal tension cracking load and ultimate shearing load were developed. The equation for the initial cracking load was obtained from test data as an empirical expression. For the case of simple beams it was found that the initial diagonal cracking is affected by the strength of concrete and the ratio of shear span to the effective depth only.

It was stated that if a beam can sustain a load greater than the cracking load, a redistribution of internal stress will take place after the formation of diagonal crack. As a result of destruction of concrete in the compression zone above or below the diagonal tension crack, shear failure occurs. With the aid of several assumptions, a

general ultimate moment equation was developed by a semi-rational approach. Eq. (13) is the ultimate moment equation for simple beams with vertical stirrups suggested by Moody-Viest.

$$\frac{M_s}{k_1 k_3 f_c' b d^2} = \frac{p f_s}{k_1 k_3 f_c'} \left(1 - K_2 \frac{p f_s}{k_1 k_3 f_c'} \right) + \frac{T_v \cdot \bar{x}}{k_1 k_3 f_c' b d^2} \quad (13)$$

Discussion of the current investigations In both the investigations by Moretto and Clark only simply supported beam specimens were tested. The equations of the ultimate shearing load were obtained empirically from the ultimate nominal shearing stresses with the factors known to affect the shearing load. Eqs. (11) and (12) are of similar form except that the ratio of shear span to the effective depth is introduced into Eq. (12). A comparison between the actual nominal shearing stresses of the beams tested by the investigators mentioned in this chapter and the computed shearing stresses by Eqs. (11) and (12) shows that Eq. (12) gives much better results. This indicates that the ratio of shear span to the effective depth plays an important role on the shearing strength of reinforced concrete beams.

For the tested beams without web reinforcement Eq. (13) predicts shear strengths of the test beams closer than Eqs. (11) and (12). But for the most of the tested beams with web reinforcement both Eqs. (12) and (13) can predict the shearing strengths within 10 per cent error. Because Eq. (13) is somewhat complex in its form, and usually reinforced concrete beams in actual practice have web reinforcement it is preferable to use Eq. (12) or similar form of equation for estimating the shearing strength of beams. On the other hand Eq. (12) is not applicable to restrained beams. Eq. (13) is therefore valuable for this kind of beams.

CHAPTER V

THEORIES AND METHODS OF EVALUATION OF THREE IMPORTANT
FACTORS IN DIAGONAL TENSION STRENGTH

As stated in the previous chapter, all the current investigations of diagonal tension in reinforced concrete beams required strain gages to determine the internal stresses. In this investigation a new approach was attempted without using strain gages. The time and labour in setting up the strain gages was saved and the testing procedures were much simplified.

From the studies of the current investigations shearing strength of a reinforced concrete beam is composed of three important factors, namely: (1) the shearing strength of the longitudinal tension steel; (2) the shearing strength developed by tension in web reinforcement, and (3) the shearing strength of uncracked concrete above the neutral axis. The theories and methods of evaluation these three factors will be presented in the succeeding paragraphs of this chapter.

Consider a reinforced concrete beam with vertical stirrups in Fig. 5 failing due to diagonal tension. Assume the diagonal tension cracks incline from the end of the support bearing plates to the neutral axis. Then, the free body diagram of the left part of the beam ~~are~~ is shown in Fig. 5A. The vertical forces acting on the free body are as follows:

1. The vertical reaction R_{III} at the support.
2. The vertical shearing force S_T of the longitudinal tension steel.

3. The resultant of the tensile force of the stirrups T_v .

4. The vertical concrete shearing force S_c above the neutral axis.

For equilibrium, $\Sigma V = 0$

$$R_{III} = S_T + T_v + S_c \quad (14)$$

Seven ordinary reinforced concrete beams of this kind were made in this investigation. They were called beams of Series III. The details of these beams will be described in Chapter VI.

Method of evaluating the shearing strength of the longitudinal tension steel Any factor in resisting diagonal tension may be evaluated easily by testing a reinforced concrete beam with the other two factors isolated. The beam in Fig. 3 is a beam similar to the one in Fig. 5 except that no web reinforcement is provided and a portion of the compression concrete is replaced by a set of bearing plates and rollers. This kind of beams was called beams of Series I in this investigation. This beam offers no shearing resistances by uncracked concrete and stirrups, yet the compressive forces can be transmitted through the nest of rollers. After the formation of the diagonal tension crack, no stresses can exist in the concrete across the crack. The only forces to resist the reaction is the vertical shearing force of the longitudinal steel. If the diagonal tension crack is similar to the one in Fig. 5, the free body diagram for this beam at failure may be shown in Fig. 3A.

$$\text{For equilibrium, } \Sigma V = 0 \quad R_i = S_T \quad (15)$$

$$\text{But} \quad R_i = \frac{P_i}{2} \quad \text{and} \quad S_T = A_s \cdot s_T$$

$$\text{Therefore} \quad S_T = \frac{P_i}{2A_s} \quad (16)$$

where R_1 and P_1 are the reaction and applied load respectively of the beam in Fig. 4 at failure. Hence the shearing resistance offered by the longitudinal tension bars of a reinforced concrete beam may be obtained by testing a similar beam without stirrups but with rollers in place of a portion of concrete. Its magnitude may be equal to the ultimate reaction of the latter beam if their diagonal tension cracks are similar. Moreover, its shearing stress may be equal to the ultimate load divided by twice the area of its longitudinal reinforcement.

Method of evaluating the shearing strengths developed by tension in vertical stirrups and uncracked concrete The shear force taken by vertical stirrups may be evaluated indirectly by testing similar beams with gaps in the compression zone. The beam in Fig. 4 is a beam similar to that in Fig. 5 except that a nest of rollers is inserted. After the formation of the diagonal tension crack the reaction at the support will be resisted by the shearing strength developed by the longitudinal steel and the vertical stirrups. If the diagonal tension crack is similar to the one in Fig. 5, the free body diagram for this beam at failure may be shown in Fig. 4A. The vertical forces in this diagram are the reaction R_{II} at the support, the resultant T_v of the tensile forces in the stirrups, and the vertical shearing force S_T of the longitudinal tensile steel.

$$\text{For equilibrium} \quad \Sigma V = 0 \quad R_{II} = S_T + T_v \quad (17)$$

$$\text{But} \quad S_T = R_I$$

$$\therefore T_v = R_{II} - R_I \quad (18)$$

$$\text{Ave.} \quad f_v = \frac{R_{II} - R_I}{m A_v} \quad (19)$$

$$m A_v$$

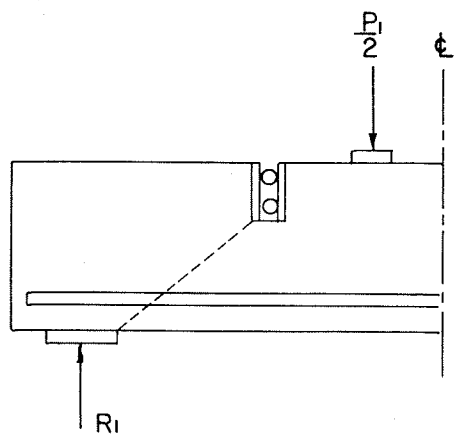

FIG. 3 A BEAM OF SERIES I WITH HYPOTHETICAL CRACK

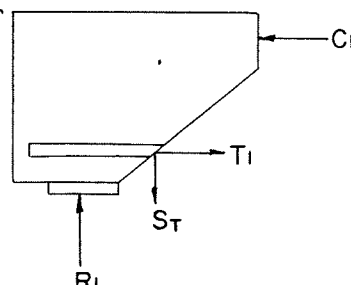

FIG. 3A THE FREE BODY DIAGRAM OF BEAM IN FIG. 3

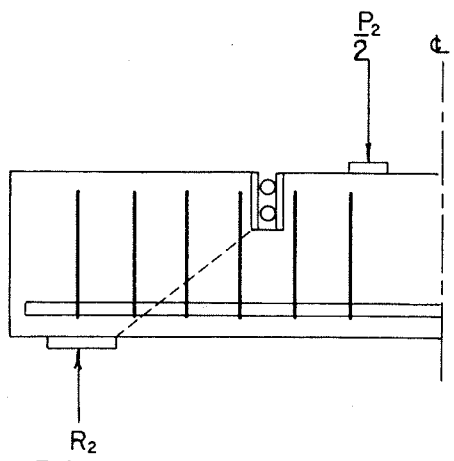

FIG. 4 A BEAM OF SERIES II WITH HYPOTHETICAL CRACK

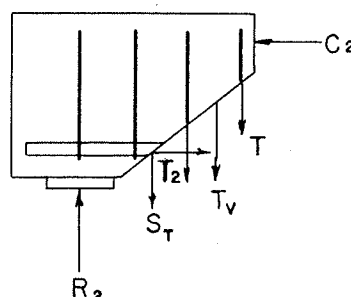

FIG. 4A THE FREE BODY DIAGRAM OF THE BEAM IN FIG. 4

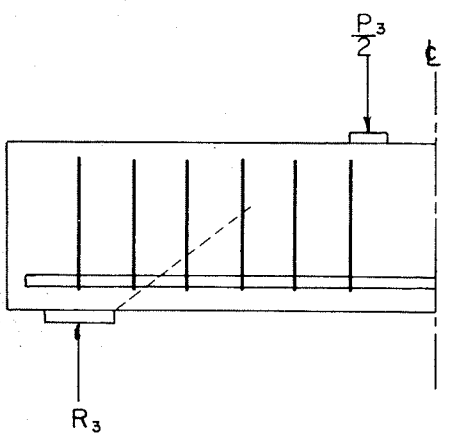

FIG. 5 A BEAM OF SERIES III WITH HYPOTHETICAL CRACK

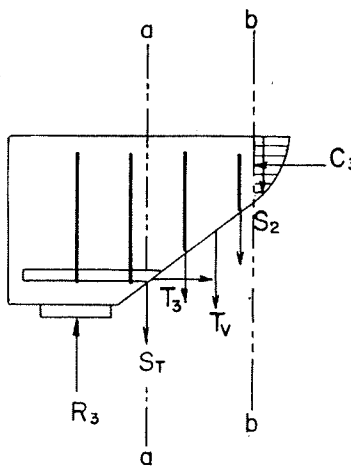

FIG. 5A THE FREE BODY DIAGRAM OF THE BEAM IN FIG. 5

where f_v is the critical tensile stress in the stirrups and n is the number of the stirrups across the diagonal tension crack.

Therefore the shearing force taken by the stirrups of a reinforced concrete beam may be equal to the difference of the end shears of a beam in Series I and its corresponding beam in Series II provided that their diagonal tension cracks are similar. Furthermore, the average vertical tensile stress in the stirrups may be obtained by dividing the shearing resistance of the stirrups by the total area of the stirrups across the diagonal tension crack.

After the shear resistances of the longitudinal tension bars and the stirrups have been evaluated, the shear force taken by the uncracked concrete above the neutral axis may be determined indirectly from the test results of the corresponding beams in Series II and III.

$$\text{From Eqs. (14) and (17)} \quad S_c = R_{III} - R_{II} \quad (20)$$

Therefore the shear resistance of the uncracked concrete above the neutral axis may be equal to the difference of end shears of the corresponding beams in Series III and II.

Redistribution of internal stresses In the free body diagram of Fig. 5.A, the moment caused by the vertical forces must be balanced by the couple of the horizontal forces. The horizontal forces acting on the free body are the horizontal tension of the longitudinal tension steel and compressive stresses above the neutral axis. The magnitude of the horizontal tension cannot be computed from the bending moment at Section a-a as in the usual manner. However, it may be determined by taking moments about Section b-b if the reaction at the

support and the forces taken by the stirrups and the tension reinforcement are known. The changes of relationship of usual tensile stresses due to the formation of diagonal tension are known as redistribution of internal stresses.

CHAPTER VI

SPECIMENS, EQUIPMENT, AND TEST PROCEDURES

Specimens There were twenty-one simply supported rectangular beams in three series, Series I, II and III, in this investigation. Each series contained seven beams. They were of same size with a cross section 8 X 14 inches and a length of six feet long. The nominal concrete strengths varied from 2,000 psi to 5,000 psi. The majority of the beams had a nominal concrete strength of 3,500 psi. The effective depth of the beams was $11\frac{1}{2}$ inches approximately. Three different amounts of longitudinal reinforcement were used; namely, 3 - No. 8, 3 - No. 9, and 3 - No. 10 deformed bars. Consequently, the ratios of the area of the tensile steel bars to the effective cross sectional area of the concrete were 0.0256, 0.0326, and 0.0412 respectively. All the beams were designed to fail in diagonal tension.

Beams of Series I The beams of Series I were planned to investigate the shear strength of the longitudinal tension reinforcement. No web reinforcement was provided. A portion of the compression concrete two and one half inches wide and five inches deep was replaced by two bearing plates and two rollers. Figs. 20 - 26 show the detail of each beam of this series. The nominal concrete strengths and the amount of tension steel are listed in Table I.

Beams of Series II These beams were designed to study the contribution of the web reinforcement to the shearing strength. They were similar to their corresponding beams in Series I except that vertical stirrups were provided. All the web reinforcement was of No. 3

deformed bars. Three different spacings of stirrups were used: three inches, four and one half inches, and six inches. The details of beams of Series II are shown in Figs. 27 - 33 and in Table 2.

Beams of Series III These beams were designed to study the shearing strength offered by the concrete. The beams in this series were identical to those of Series II without gap. The details of these beams are shown in Figs. 34 - 40 and listed in Table 2.

Types of Loading Since shear span is also one of the factors influencing the shearing strength of reinforced concrete beams, different loading conditions were used in order to study the effects of various shearing spans on shearing strength. All the beams except Beam IIIA1 were tested in three different types of loading. The loading for Beam IIIA1 was a special loading which is shown in Fig. 34.

(1) "A" Loading -- the load was applied at the center of the span.

(2) "B" Loading -- the load was applied at the points six inches from the center line of the span.

(3) "C" Loading -- the load was applied at the third points of the span.

Designation of beams In the designation of beams the Roman numeral was used to designate the series, the following letter identified the type of loading and the last Arabic numerals was the specimen number in each series. The beams in the three series having the same Arabic numerals were corresponding beams which formed a combination for evaluating the three factors of shearing strengths. Of course, Beam IIIA1 was an exceptional beam which had no relation to any other beam at all.

TABLE 1
DETAILS OF SPECIMENS OF SERIES I

Beam No.	$\frac{a}{d}$ (ratio)	Nominal f'_c (psi)	Tensile Steel	
			Pieces & Bar No.	$p = A_s/bd$
IA1	2.61	3,500	3 - No. 8	0.0256
IA2	2.61	3,500	3 - No. 9	0.0326
IB3	2.09	2,000	3 - No. 8	0.0256
IB4	2.09	3,500	3 - No. 9	0.0326
IB5	2.09	5,000	3 - No. 10	0.0412
IC6	1.75	3,500	3 - No. 9	0.0326
IC7	1.75	5,000	3 - No. 9	0.0326

TABLE 2
DETAILS OF SPECIMENS OF SERIES II & III

Beam No.	$\frac{a}{d}$ (ratio)	Nominal f'_c (psi)	Tensile Steel		No. 3 Stirrups	
			Pieces & Bar No.	$p = A_s/bd$	s (in)	$r = A_v/bs$
IIA1	2.61	3,500	3 - No. 8	0.0256	6	0.00458
IIIA1	1.305	3,500	3 - No. 8	0.0256	6	0.00458
II & IIIA2	2.61	3,500	3 - No. 9	0.0326	$4\frac{1}{2}$	0.00610
II & IIIB3	2.09	2,000	3 - No. 8	0.0256	6	0.00458
II & IIIB4	2.09	3,500	3 - No. 9	0.0326	$4\frac{1}{2}$	0.00610
II & IIIB5	2.09	5,000	3 - No. 10	0.0412	3	0.00916
II & IIIC6	1.75	3,500	3 - No. 9	0.0326	$4\frac{1}{2}$	0.00610
II & IIIC7	1.75	5,000	3 - No. 9	0.0326	$4\frac{1}{2}$	0.00610

Design of beams Since the failure of the specimens by other than diagonal tension was not desirable, all beams were designed to fail in diagonal tension. Each beam of Series III was designed in such a way that its flexural capacity was greater than its shear capacity. The estimated ultimate moments due to flexural failure were based on the formulas in the article "The Plasticity Ratio of Concrete and Its Effect on the Ultimate Strength of Beams" by V. P. Jensen, while those due to shear failures were based on Moody-Viest formulas. The estimated loads for shear failures were also checked by Clark's formula. It was understood that the shear capacities for the beams of Series I and II would be lower than their corresponding beams in Series III and yet the flexural capacities would not decrease if the cement mortar for grouting the steel plates were strong enough to resist the compression. Therefore, computations for the design of these two series of beams were not necessary.

Materials All beams were made with ordinary portland cement. The specific gravity of the cement was 3.13. Both the specific gravity of fine and coarse aggregate were 2.65. The average fineness modulus of the sand was 3.02. The maximum size of the limestone aggregate was 3/4 inch. The surface moisture of the sand was 2.5%. The surface moisture of the lime stones was 0.4%.

Deformed bars of structural steel were used for the reinforcement of the beams. Control tests of two tensile coupons of No. 3 bars were made. The physical properties of Nos. 8, 9, and 10 bars were obtained from the analysis and physical report of Manitoba Rolling Mill Co. Ltd.

TABLE 3
PHYSICAL PROPERTIES OF STEEL BARS

Bar No.	Yield Point strength (psi)	Tensile strength (psi)	Elongation % in 8" long
3	63,000	84,500	18.3
8	54,000	80,500	20.7
9	47,400	76,700	23.0
10	44,200	73,800	25.8

Design of concrete mixtures The concrete mixtures of the beams were designed to attain their corresponding nominal concrete strengths 2,000 psi, 3,500 psi, and 5,000 psi. The average mixture ratios and water cement ratios are shown in Table 4. Trial mixes were used so that the slumps were within the limit of one inch to two inches. Stiff concrete was required because of the use of vibrators.

TABLE 4
RATIO OF CONCRETE MIXTURES

Nominal f'_c (psi)	Ave. Mixtures Ratios by weight Cement: Sand: Gravel	Cement water Ratio by Weight
2,000	1 : 4.4 : 3.22	1.35
3,500	1 : 2.85 : 2.64	1.76
5,000	1 : 1.76 : 1.83	2.93

The actual concrete strengths are listed in Table 5,
 Chapter VII.

Fabrication of specimens The reinforcement for each beam of Series II and III was arc welded into a rigid cage as shown in Figs. 6 and 7. Two short No. 3 bars were welded at the quarter points of the longitudinal tension bars for each beam of Series I for the purpose of connecting them in proper spacing. In order to avoid possible failure of bond and anchorage, 1", 1-1/8", and 1 1/4" heavy plain washers were welded to both ends of the Nos. 8, 9, and 10 steel bars respectively. All reinforcement was supported by two inches high steel chairs in steel forms.

All the beams were cast in well oiled steel forms which mounted on the external vibrators as shown in Fig. 8. The vibrators were driven by an electric motor between the ends of the steel forms. The concrete was mixed in a tilting rotary mixer by the side of the steel forms. All batching was weighed by scale. The concrete was chuted into the forms. After each batch had been placed in the form, the concrete mixture was vibrated for about one minute for beams of Series I and II. Since two and one half batches were required to fill up one form, the total time of vibration required was about three minutes for these two series. No definite time was kept for the vibration of Series III. The time of vibration was judged only by the appearance of the concrete. Because this series of beams were the beginning few beams to be poured in the newly manufactured vibrators, steel hangers 3/8" D. and 12" deep were inserted in both ends of the beams to facilitate transportation. Great care should be taken that they would not cross the cracks and act as stirrups.

Forms were removed two days after casting. The beams were painted with a coat of Horncure. It is a liquid for curing concrete.

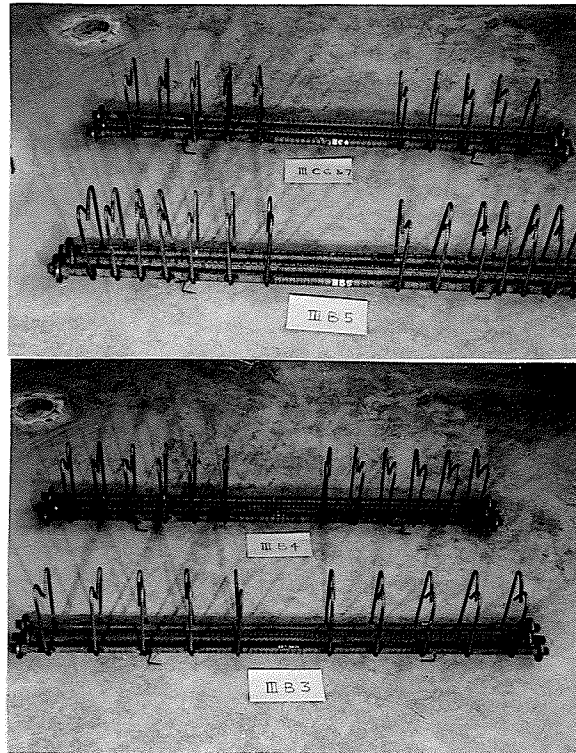

FIGURE 6
REINFORCEMENT OF BEAMS OF SERIES II & III
SUBJECTED TO "B" & "C" LOADINGS

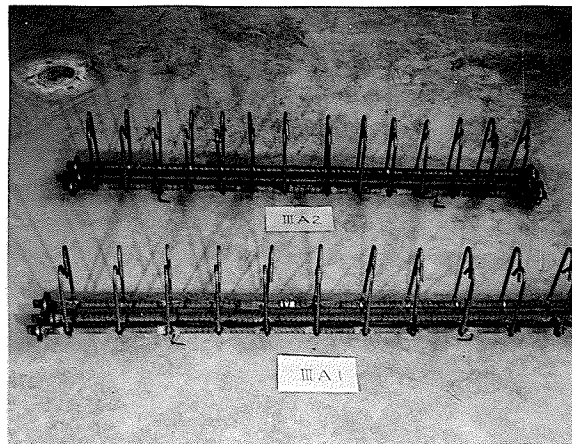

FIGURE 7
REINFORCEMENT OF BEAMS OF SERIES II & III
SUBJECTED TO "A" LOADING

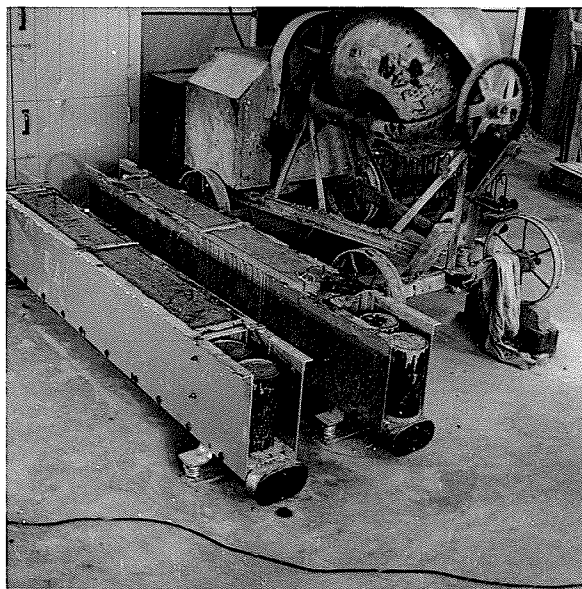

FIGURE 8

EQUIPMENT FOR FABRICATING CONCRETE BEAMS & CYLINDERS



FIGURE 9

CONCRETE BEAMS & CYLINDERS PILED UP
IN THE LABORATORY BEFORE TESTS

It hardens to form a thin membrane which prevents the concrete from the action of rapid drying. All the beams were stored in the air of the laboratory and tested at the age of twenty eight days. The picture in Fig. 9 shows the concrete beams piled up before tests. All the beams were white washed prior to tests so that cracks would become readily visible during the tests.

In pouring the beams of Series I and II a wooden block $3\frac{1}{4}$ " at the top, 3" at the bottom, 5" deep, and 8" long was inserted in each beam in proper position. The distances from the center of the blocks to the ends of the beams were $2'-3"$, $1'-9\frac{1}{2}"$, and $1'-7\frac{1}{2}"$ for the beams having the "A", "B", and "C" Loadings respectively. All the wooden blocks had been well soaked with water and then oiled before they were used, thus facilitated their removal from concrete. Since wooden blocks swell when they are soaked with water and shrink when they dry. The blocks were hammered out to form gaps where the nest of rollers were grouted in. Each nest of rollers consisted of two steel plates, $10" \times 5" \times \frac{1}{2}"$, and two steel rollers $1\frac{1}{2}" \text{D.} \times 10"$ long. In grouting the nest of rollers both ends of the steel plates were clamped in order to hold the rollers in the desired position. Cement mortar of 1:1 mixed was used for grouting.

Two standard $6" \times 12"$ control cylinders for each beam were cast in paraffined cardboard molds in the same way and at the same time as the beam by putting them at the end of the steel form as shown in Fig. 8. The concrete cylinders were cured and stored in the same manner as the beams and were tested at the same age as the corresponding beams to determine the actual concrete strengths. The cylinders for beams

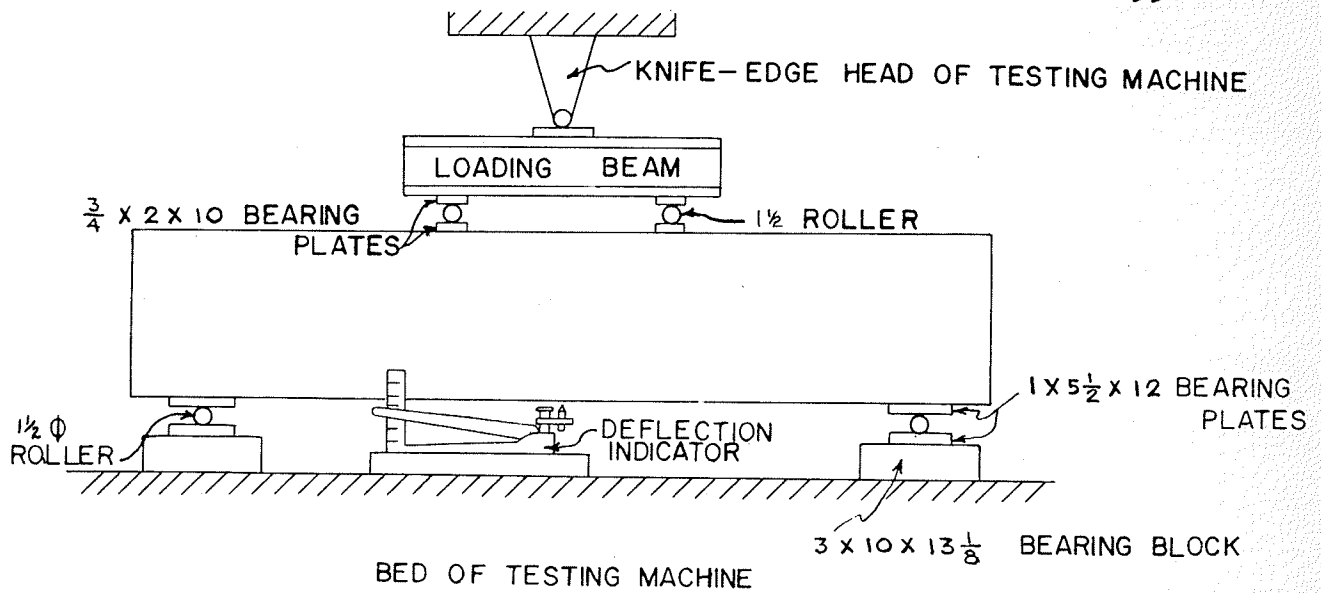

FIGURE 10
 SKETCH SHOWING TESTING ARRANGEMENT
 FOR BEAM SPECIMENS

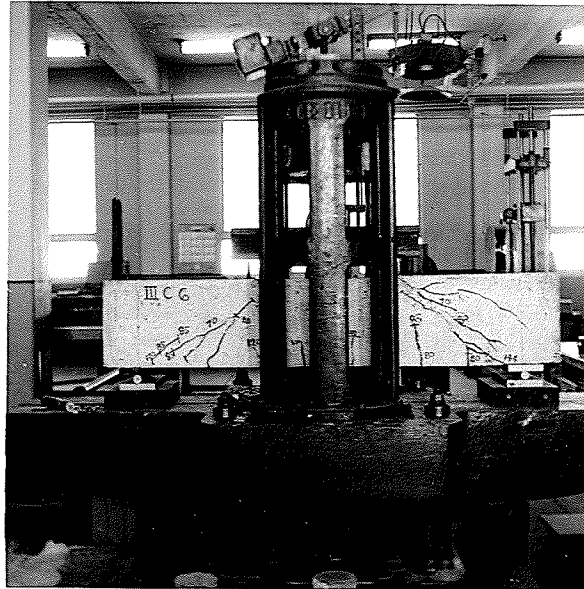

FIGURE 11
 PICTURE SHOWING TESTING ARRANGEMENT
 FOR BEAM SPECIMENS

of Series I were capped with plaster of Paris while those of Series II and III were capped with Vitro Bond which is a material made with tar and sulphur.

Test equipment and procedure The beams were tested with a five foot span in three different types of loadings except Beam IIIA1. A 200,000 pound capacity Riehle testing machine of the beam type was used. Details of the testing arrangement were shown in Figs. 10 and 11.

The load was applied in increments until failure. For most beams of Series I the increment was 5,000 pounds from zero load up to a total load of 20,000 pounds, then the increment was decreased to 2,000 pounds until failure occurred. For beams of Series II and III all increment of load was 5,000 pounds. After each increment the deflection at the center of each beam was measured by the Riehle cantilever type deflection indicator. The cracks were also traced and recorded at the same time. The progress of cracking and phenomenom of failure were observed visually and recorded by camera.

CHAPTER VII

TEST RESULTS

This chapter is devoted to presenting all the test results in tables, graphs, and photographs in connection with this investigation. The behaviors of the specimen beams will be discussed in detail in the latter part.

The test results of the three series of reinforced concrete beams are tabulated in Table 7. Both the cracking loads and the failure loads were measured by the testing machine. The cracking loads are the loads at the formation of initial diagonal tension crack and they were based on visual observations in the tests. The compressive strengths of the concrete beams in Table 7 are the average values determined from the tests of control cylinders. The individual strengths of the concrete cylinders are listed in Table 5. The yield point strengths, ultimate tensile strengths and elongations of two No. 3 steel bars are shown in Table 6.

The load deflection curves for the corresponding beams in the three series except Beam IIIA1 were plotted on the same sheets for comparison. They are presented in Figs. 12-19. Since Beam IIIA1 was tested under special loading condition, its load deflection curve is shown on a separate sheet in Fig. 12.

The progress of cracking and the crack patterns of the beams are shown in the photographs of Figs. 20-40. The detail of each beam is also presented between the photographs of the crack patterns on both sides

of the beam for reference. The unit of the loads recorded in the pictures is given in kips.

In testing reinforced concrete beams three different stages may be distinguished: (1) Behavior prior to formation of diagonal tension cracks, (2) Behavior during diagonal tension cracking, and (3) Behavior after formation of diagonal cracks. The behaviors of the beams specimens will be discussed in the following paragraphs.

TABLE 5
CYLINDER TESTS

Beam No.	Nominal f_c (psi)	Total Load (pounds)	Comp. - stress (psi)	Ave f_c (psi)
IA1	3500	121,410	4,300	4,180
		114,870	4,060	
IA2	3500	133,610	4,720	4,580
		125,170	4,430	
IB3	2000	68,760	2,430	2,270
		59,650	2,110	
IB4	3500	108,710	3,840	3,780
		105,180	3,720	
IB5	5000	144,200	5,100	5,260
		153,230	5,420	
IC6	3500	89,360	3,160	3,650
		117,030	4,130	
IC7	5000	156,020	5,510	5,420
		151,010	5,330	
IIA1	3500	119,260	4,200	4,200
		80,500	2,840*	
IIA2	3500	123,000	4,350	4,270
		118,180	4,180	
IIB3	2000	67,540	2,380	2,420
		69,620	2,460	
IIB4	3500	109,090	3,860	3,910
		111,710	3,950	
IIB5	5000	152,460	5,380	5,540
		162,080	5,700	
IIC6	3500	103,980	3,680	3,730
		107,130	3,780	

TABLE 5 - continued

Beam No.	Nominal f'_c (psi)	Total Load (pounds)	Comp.- stress (psi)	Ave f'_c (psi)
IIC7	5000	93,680	3,300* ²	4,980
		141,580	4,980	
IIIA1	3500	847,130	2,990	2,910
		801,200	2,830	
IIIA2	3500	114,080	4,040	4,150
		120,550	4,260	
IIIB3	2000	59,610	2,100	1,810
		42,720	1,510	
IIIB4	3500	76,110	2,700	3,670
		131,000	4,630	
IIIB5	5000	64,870	2,290	2,740
		90,090	3,180	
IIIC6	3500	131,020	4,630	4,630
		-	-	
IIIC7	5000	184,660	6,520	5,490
		126,010	4,450	

Note - The area of cylinder = 28.3 sq.in.

*¹The strength of this cylinder was believed to be unreliable since it was so much different from the strengths of the three other cylinders of IIA1 and IIA2 which were made with the same mix, cured in the same way and tested on the same date.

*²The failure of this cylinder might be due to the uneven loading from the hemispherical loading block where some Vitrobond material adhered to it. Therefore the strength of this cylinder was not considered to be representative.

TABLE 6

TEST OF #3 STEEL BARS

	Area (sq.in)	Yield Pt. Load (lb)	Ult. Load (lb)	Yield Pt. Strength (psi)	Ult. Tensile Strength (psi)	Elongation % in 8" Long
1st bar	0.111	7,000	9,375	63,000	84,500	17.5
2nd bar	0.111	7,000	9,410	63,000	84,800	19.0
Mean	0.111	7,000	9,394	63,000	84,650	18.25

TABLE 7
RESULTS OF TESTS OF THREE DIFFERENT SERIES
OF BEAM SPECIMENS

Beam No.	Nominal f'_c (psi)	Actual f'_c (psi)	Initial D.T. Cracking Load (Kips)	Ultimate Load (Kips)	$v_u = \frac{V}{bjd}$ (psi)	$\frac{P_u}{P_c}$	Mode of Failure
IA1	3500	4180	30	32.00	198	1.07	T.
IA2	3500	4430	25	27.00	168	1.08	T.
IB3	2000	2270	34	35.00	217	1.03	T.
IB4	3500	3780	40	48.00	298	1.20	T.
IB5	5000	5260	40	41.57	258	1.04	T.
IC6	3500	3650	40	72.00	447	1.80	T.
IC7	5000	5420	44	81.98	510	1.87	T.
IIA1	3500	4200	30	76.00	472	2.53	D.T.
IIA2	3500	4270	40	94.00	583	2.35	D.T.
IIB3	2000	2420	35	76.00	472	2.17	D.T.
IIB4	3500	3910	40	103.45	643	2.58	D.T.
IIB5	5000	5540	55	128.85	800	2.34	D.T.
IIC6	3500	3730	40	95.00	590	2.38	D.T.
IIC7	5000	4980	45	115.00	714	2.55	D.T.
IIIA1	3500	2910	75	138.86	865	1.85	D.T.
IIIA2	3500	4150	65	91.36	567	1.52	T.
IIIB3	2000	1810	35	73.89	458	2.11	D.T.
IIIB4	3500	3670	55	121.27	754	2.21	T.
IIIB5	5000	2740	50	113.89	708	2.28	D.T.
IIIC6	3500	4630	70	144.00	895	2.06	D.T.
IIIC7	5000	5490	70	145.00	900	2.07	D.T.

Note: T - tension failure D.T. - diagonal tension failure

APPLIED LOAD IN KIPS

140

120

100

80

60

40

20

0

0

01

02

03

04

05

06

DEFLECTION AT CENTER OF SPAN IN INCHES

FIGURE 12

LOAD DEFLECTION CURVE FOR BEAM IIIA1

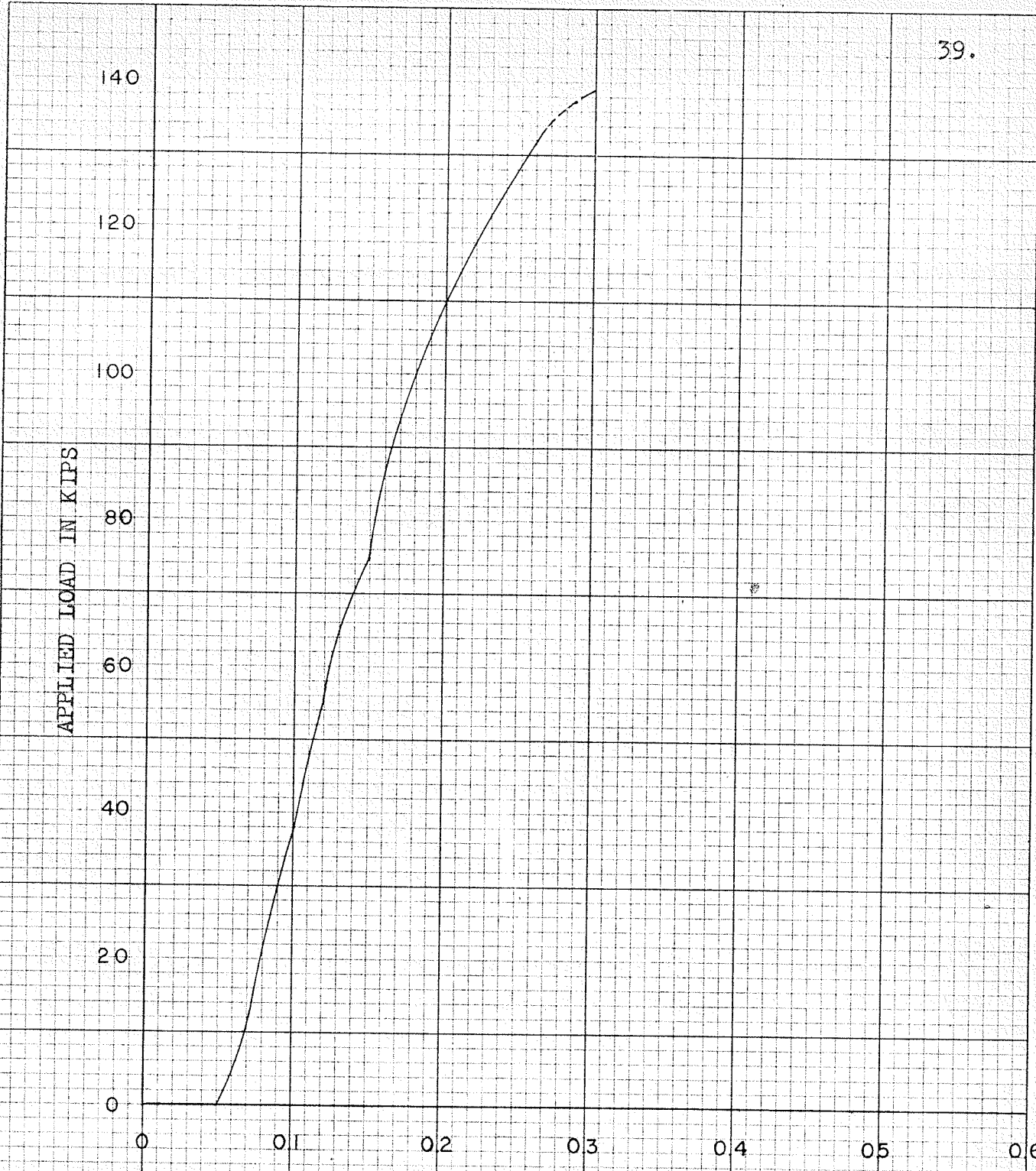

APPLIED LOAD IN KIPS

80
60
40
20
0

0 0.1 0.2 0.3 0.4 0.5 0.6

DEFLECTION AT CENTER OF SPAN IN INCHES

FIGURE 13

LOAD DEFLECTION CURVES FOR BEAMS IAI & IIAI

IIAI

IAI

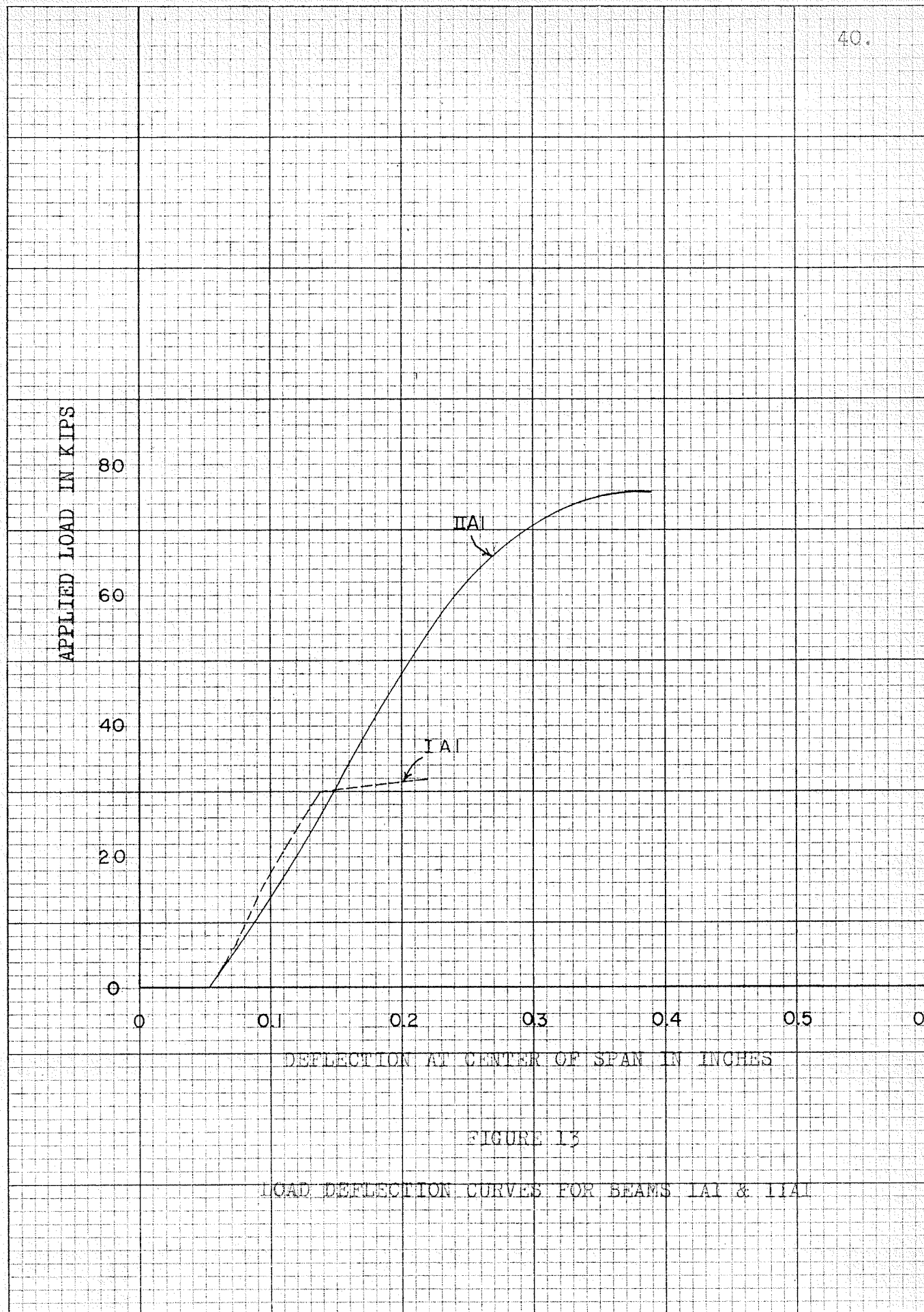

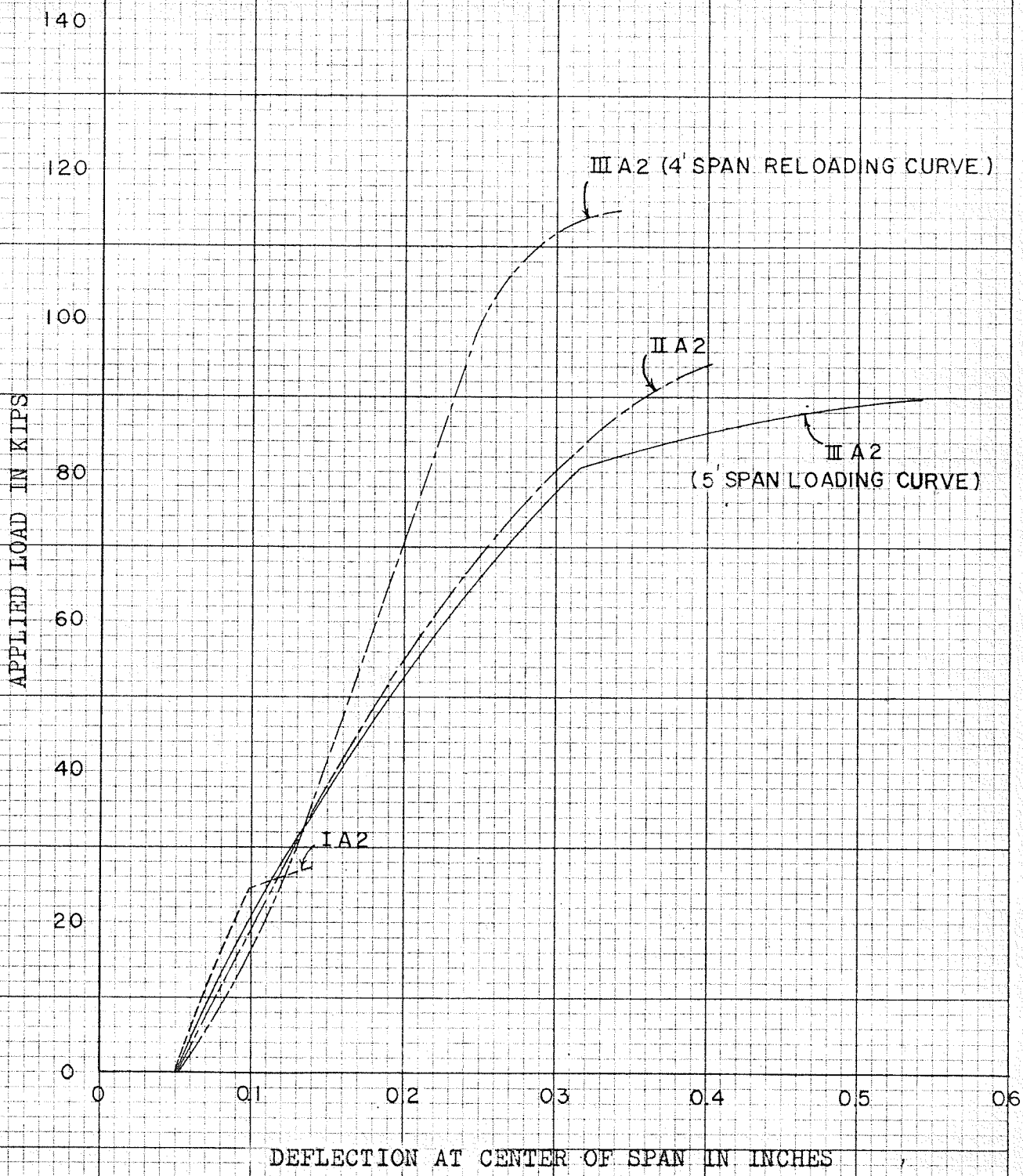

FIGURE 14
LOAD DEFLECTION CURVES FOR BEAMS IA2, IIA2, & IIIA2



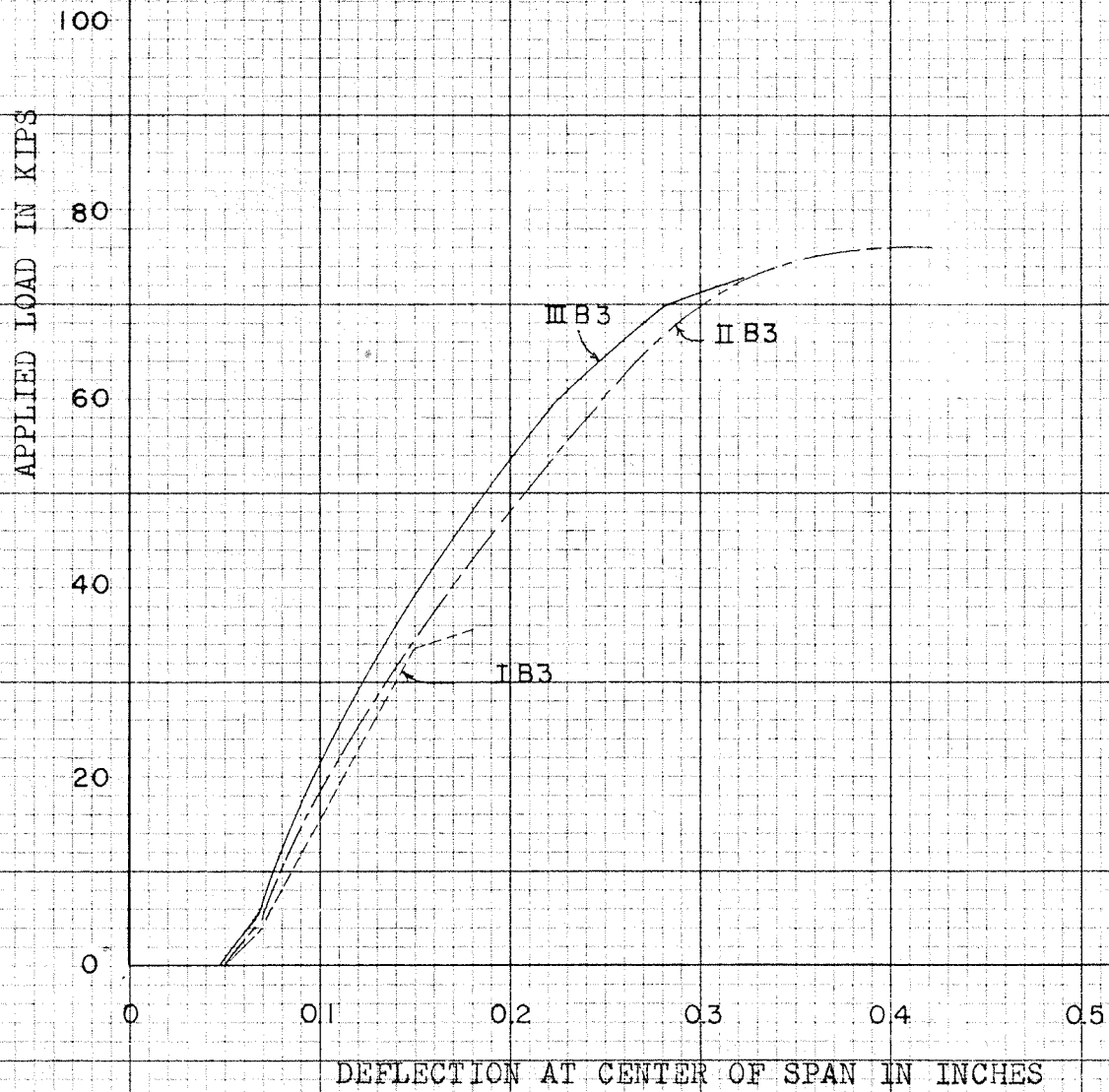

FIGURE 15

LOAD DEFLECTION CURVES FOR BEAMS IB3, IIB3, & IIIB3