

**An Improved Cox Proportional Hazards Model for Reliability
Analysis of Aviation Gas Turbines Considering Varying
Environmental Conditions and Operational Settings**

By

Bo Cui

A Thesis Submitted to the Faculty of Graduate Studies of

The University of Manitoba

In partial fulfillment of the requirements of the degree of

MASTER OF SCIENCE

Department of Mechanical Engineering

University of Manitoba

Winnipeg, Manitoba

Copyright © Bo Cui, 2025

Abstract

Aviation gas turbines are critical components in the aerospace industry, where reliability directly influences maintenance costs, operational efficiency, and safety. The Cox proportional hazards model (Cox model) is crucial in reliability analysis, traditionally employed to evaluate the impact of multiple covariates on the likelihood of failure. However, its application in aviation gas turbines has revealed limitations, particularly when working conditions and gas path parameters are used as direct covariates. These factors, while relevant, often fail to fully capture the degradation process due to their sensitivity to varying working conditions.

In recent years, the integration of machine learning techniques with the Cox model has gained traction, offering a potential pathway to enhance the accuracy of reliability predictions. Despite this progress, existing approaches still predominantly rely on direct covariates that may not accurately reflect the underlying degradation of gas turbines. This thesis proposes a novel method that leverages machine learning to generate new, more robust covariates for the Cox model. By first modeling a healthy gas turbine, the method produces covariates that are less influenced by the variability in working conditions, leading to a more precise representation of turbine degradation over time.

The thesis explores the theoretical foundations of this approach, detailing how machine learning algorithms can be employed to model a healthy gas turbine and subsequently generate new covariates that better align with the actual degradation process. This method addresses the inherent limitations of conventional covariates, providing a more comprehensive method for reliability analysis under varying operational scenarios.

The effectiveness of the proposed method is validated through extensive experiments using the NASA C-MAPSS dataset, which includes data from turbofan engines operating under diverse conditions. Comparative analysis demonstrates that the improved Cox model, enhanced with machine learning-derived covariates, offers better accuracy in predicting gas turbine reliability compared to the traditional model. The results demonstrate the potential of this approach to significantly improve reliability assessments in the aerospace industry, ultimately contributing to safer and more efficient operations.

This research not only advances the application of the Cox model in the context of aviation gas turbines but also opens new avenues for integrating machine learning to generate new covariates with traditional reliability analysis techniques. The findings have broader implications for the aerospace industry and could inform future developments in turbine maintenance strategies and operational practices.

Acknowledgment

I would like to express my deepest gratitude to my academic supervisor, Dr. Xihui Liang, for his invaluable guidance and support throughout this work. His patience and expertise have been instrumental in shaping this thesis, and it would not have been possible to complete it without his insightful suggestions and constructive comments. I am also profoundly grateful to Dr. Liang for providing me with the opportunity to enhance my academic background and experience a new chapter of life.

I am deeply thankful to my wife, whose unwavering support has been my foundation since the day we arrived in Canada. She has selflessly devoted much of her time to caring for our family, allowing me the space and time needed to focus on my research. Her encouragement, wisdom, and love have been a constant source of strength during challenging times, and I could not have navigated this journey without her.

I would also like to express my heartfelt appreciation to my son. His presence in my life has been a constant source of motivation, reminding me of the importance of hard work and dedication. Being a role model for him has driven me to push through difficulties and strive for excellence.

I am grateful to Shazaib Ahsan, with whom I have shared this academic journey since my transition from 11 years in the manufacturing industry. Our collaboration and mutual support have made the academic challenges more manageable, and I am thankful for the camaraderie we've built.

Special thanks to Xin Wang and Geontae Kim for the friendship we have forged and the memorable times we've shared. These experiences have enriched my time here, making this period of my life truly meaningful.

Table of Contents

Abstract.....	i
Acknowledgment.....	iii
Table of Contents	iv
List of Tables.....	vi
List of Figures.....	vii
Abbreviations	viii
1 Introduction.....	1
1.1 Overview of Gas Turbines and the Importance of Reliability	1
1.2 Motivation	5
1.3 Objectives.....	6
1.4 Thesis Structure.....	8
2 Literature Review in Reliability Analysis for Gas Turbines	10
2.1 Statistical-based Methods	10
2.1.1 Parametric Method	11
2.1.2 Non-parametric Method	14
2.1.3 Semi-parametric Method.....	18
2.2 Cox-based Reliability Analysis method for Gas turbines	19
2.2.1 Evolution of the Baseline Hazard Function in the Cox Model	20
2.2.2 Advancements in the Covariate Term of the Cox Model	28

2.2.3 Integration of Machine Learning with Cox Model	34
3 Fundamentals of the Proposed Method	40
3.1 XGBoost.....	41
3.1.1 Taylor Approximation	41
3.1.2 Objective Function	43
3.2 Cox Proportional Hazards Model	45
4 The Proposed Reliability Analysis Method.....	49
4.1 Development of a Machine Learning Model to Represent a Healthy Gas Turbine	53
4.2 An Improved Cox Proportional Hazards Model	58
5 Validations Using NASA C-MAPSS Data	63
5.1 Description of the Data	63
5.2 Implementations of the Proposed Method and Validations.....	67
5.2.1 Gas Turbine Modelling and Validation	67
5.2.2 Construction of an Improved Cox Proportional Hazards Model	73
6 Conclusion	89
Reference.....	92

List of Tables

Table 1. Description of sensor measurements in C-MAPSS data [40]	64
Table 2. Summary of FD001 and FD002 subsets	65
Table 3. Validation of the modelled healthy gas turbine using FD002 subset	72
Table 4. Covariates selection based on FD002 subset	78
Table 5. Performance metrics of the proposed reliability analysis method for five gas turbines in the FD002 subset.....	83
Table 6. Performance metrics of the proposed method for 5 selected gas turbines in the FD001 subset.....	86

List of Figures

Figure 1. Applications of Gas Turbine for Power Generation and Aerospace [1], [2]	1
Figure 2. The Configuration of a Bypass Aviation Gas Turbine [3].	2
Figure 3. An example of Aviation Gas Turbine Failure	4
Figure 4. The flowchart of the proposed reliability analysis method	50
Figure 5. The details of subsystem modelling in a gas turbine.....	54
Figure 6. Flow chart of establishing an improved Cox proportional hazards model.....	59
Figure 7. The layout of the simulation model with various components connected	67
Figure 8. Gas turbine system modelling using the C-MAPSS dataset.	69
Figure 9. Visualization and selection of commonly used failure distributions (a) Log-logistic distribution	74
Figure 10. Visualization and selection of commonly used failure distributions (b) Weibull distribution	75
Figure 11. Visualization and selection of commonly used failure distributions (c) Lognormal distribution.....	75
Figure 12. Visualization and selection of commonly used failure distributions (d) Exponential distribution	76
Figure 13. Turbine 250 reliability curves updated using its operational data at cycle 50.....	82

Abbreviations

RUL	Remain Useful Life
MWPHM	Mixture Weibull Proportional Hazards Model
PCA	Principal Component Analysis
PCs	Principal Components
WPHM	Weibull Proportional Hazards Model
CRF	Conditional Reliability Function
MRL	Mean Residual Life
PHM	Prognostics and Health Management
LSTM	Long-Short-Term Memory
TBF	Time-Between-Failure
MCC	Model Correlation Coefficient
RMSE	Root Mean Square Error
GIS	Geographical Information System
HIs	Health Indices
RSF	Random Survival Forests
XGBoost	Extreme Gradient Boosting
GPP	Gas Path Predictor

RC	Residual Corrector
TRA	Throttle Resolver Angle
GridSearchCV	Grid Search Cross Validation
MAPE	Mean Absolute Percentage Error
AIC	Akaike Information Criterion
MLE	Maximum Likelihood Estimation
NASA	National Aeronautics and Space Administration
C-MAPSS	Commercial Modular Aero-Propulsion System Simulation
TRA	Throttle Resolver Angle
LPC	Low-Pressure Compressor
HPC	High-Pressure Compressor
LPT	Low-Pressure Turbine
HPT	High-Pressure Turbine
KM	Kaplan-Meier
NA	Nelson-Aalen

1 Introduction

1.1 Overview of Gas Turbines and the Importance of Reliability

Gas turbines are complex machines engineered to convert heat energy into mechanical work. The operation involves compressing air, mixing it with fuel, and igniting the mixture to produce high-pressure, high-temperature gases that drive a turbine. This sequence makes gas turbines efficient and versatile. Gas turbines are employed in different applications, ranging from power generation in the power plant to propulsion systems in the aerospace industry, as shown in Figure 1.



Figure 1. Applications of Gas Turbine for Power Generation and Aerospace [1], [2]

The gas turbine system is made up of several key components. Figure 2 illustrates the configuration of a typical bypass aviation gas turbine system. The gas turbine begins with the fan inlet, where air is drawn into the system. A significant portion of this air flows through the bypass duct, generating most of the thrust in high-bypass designs. The remaining air enters the core, passing

through the low-pressure compressor (LPC) and high-pressure compressor (HPC), where it is incrementally compressed to high pressures to enhance combustion efficiency. The compressed air then enters the combustor, where it is mixed with fuel and ignited, producing high-temperature, high-pressure gases. These gases first drive the high-pressure turbine (HPT), which powers the HPC, and then the low-pressure turbine (LPT), which drives the LPC and fan. Some compressed air is diverted as bleed air for auxiliary functions, such as cooling and pressurization. Finally, the gases exit through the exhaust, providing additional thrust.

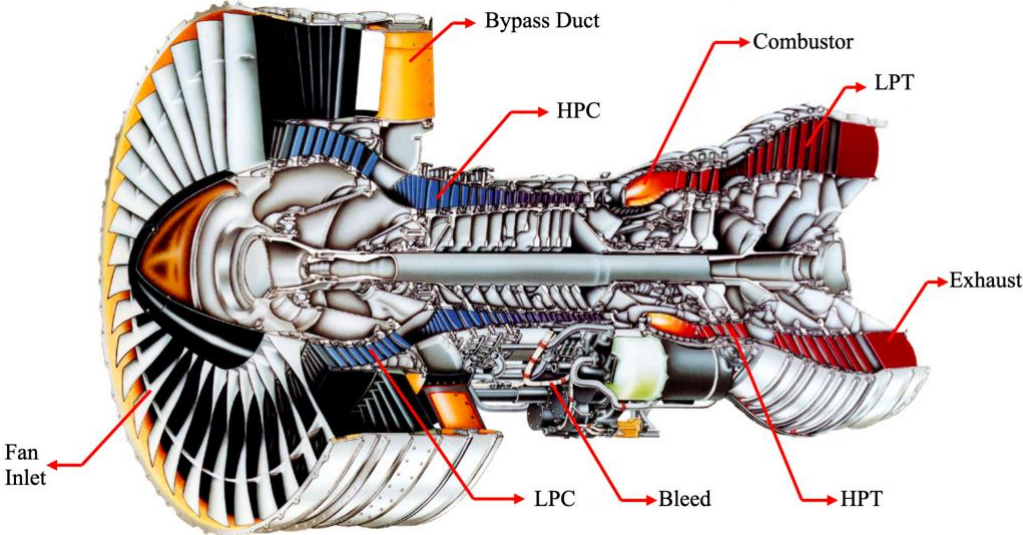

Figure 2. The Configuration of a Bypass Aviation Gas Turbine [3].

The reliability of gas turbines is critical due to their complex mechanical design and the challenging environments in which they operate. Gas turbines often function under high pressures and temperatures, requiring robust systems to maintain performance over extended periods. Ensuring reliability not only enhances operational efficiency but also minimizes the risk of unexpected failures and prolongs the lifespan of these systems. Moreover, reliability directly

impacts safety, cost-effectiveness, and overall system performance, making it a fundamental consideration in the design and operation of gas turbines.

One of the most significant benefits of reliability is its role in optimizing turbine performance. Reliable systems enable stable and consistent operations, which are essential for applications in different industrial sectors. Identifying and mitigating potential defects through comprehensive reliability design and analysis ensures that these machines perform efficiently and cost-effectively in real-world conditions. Such measures improve operational efficiency and reduce the likelihood of performance degradation over time [8], [9].

Reliability also plays a vital role in reducing failure risks. Reliability analysis techniques, such as the Weibull distribution[6], are commonly used to predict failure rates and help refine maintenance strategies. Operators can proactively address potential issues by employing these reliability analysis methods, minimizing downtime and maintenance-related costs. These preventive measures enhance system dependability and ensure that critical operations remain uninterrupted, even in demanding environments [10], [11].

From an economic perspective, the reliability of gas turbines directly influences financial outcomes. High reliability translates to reduced maintenance costs, fewer unexpected failures, and minimized downtime, all of which are essential for maintaining profitability in competitive industries. Even minor operational interruptions can lead to substantial losses, showing the economic importance of investing in reliable turbine systems. By reducing inefficiencies and ensuring consistent performance, organizations can maintain their market competitiveness and achieve long-term success [10], [13].

Furthermore, the reliability of gas turbines is crucial for ensuring safety and operational continuity[10]. Failures in high-risk environments can have severe consequences, such as fires, damage to other equipment, or significant disruptions to operations, as illustrated in Figure 3. Implementing preventive measures like the advanced reliability analysis method can mitigate these risks, ensuring the safety of personnel and the continuity of operations. This is particularly important in industries where safety and stability are crucial.



Figure 3. An example of Aviation Gas Turbine Failure

As gas turbines become more sophisticated in design and are subjected to diverse environmental and operational conditions, reliability analysis methods must adapt to meet these challenges. Reliability analysis techniques such as the Cox model and machine learning are increasingly employed and refined to better predict and understand the gas turbine's reliability, ensuring these complexities do not compromise the reliability assessment of the gas turbine.

In aviation, gas turbines operate under conditions that vary significantly due to environmental factors and operational settings. However, current reliability analysis methods often fail to

adequately address the effects of these fluctuating conditions. This oversight limits the accuracy of reliability assessments, highlighting the need for improved models that effectively consider operational variability to enhance the reliability analysis accuracy of gas turbines.

1.2 Motivation

Accurate reliability analysis of gas turbines is crucial for ensuring safety, improving operational efficiency and reducing life-cycle costs. The Cox model, a widely utilized statistical-based method in reliability engineering, is highly effective in analyzing failure data and predicting the time until specific events occur, such as malfunctions. Its strength lies in its ability to consider multiple covariates, making it a powerful tool for understanding different factors that influence reliability. Traditionally, this model has been instrumental in industries where predicting component lifespan and failure rates is essential. In recent years, there has been a growing interest in enhancing the Cox model by integrating it with machine learning techniques to improve the robustness and accuracy of reliability analysis [11], [12]. These developments include incorporating working conditions, operational settings, and gas path parameters directly as covariates in the traditional Cox model [13], [14]. However, using gas path parameters or working conditions as covariates directly presents challenges. For aviation gas turbines, these covariates are influenced not only by the inherent degradation processes of the gas turbine but also by external environmental conditions and varying operational settings. This dual influence can lead to inaccuracies in capturing the true degradation of gas turbines, thereby limiting the effectiveness and accuracy of gas turbines' reliability analysis.

To address this limitation, this research proposes a novel method for developing new covariates that more accurately reflect the degradation process while being less susceptible to variability

introduced by environmental and operational factors. By modelling a healthy gas turbine using machine learning techniques, we can generate new covariates that better represent the actual degradation occurring over time, less affected by fluctuating environmental conditions and operational settings. Integrating these new covariates into an improved Cox model enhances predictive accuracy compared to the traditional Cox model.

The goal of this research is to improve gas turbine reliability analysis by providing more accurate predictions utilizing machine learning and an improved Cox model. By developing and integrating new covariates into the improved Cox model through an advanced machine learning technique, we aim to contribute to the field of reliability engineering, particularly for gas turbine systems operating under varying working conditions and operational settings. This approach addresses the limitations of current reliability analysis methods and offers a better understanding of gas turbine reliability, yielding benefits for safety, economic performance, and technological advancement.

1.3 Objectives

The primary objective of this research is to enhance the accuracy of reliability analysis for aviation gas turbines by developing covariates for an improved Cox model that precisely reflects turbine degradation while minimizing the influence of operational settings and environmental conditions. Achieving this objective is essential for improving the predictive power of reliability assessments, thereby enabling more effective maintenance strategies and extending the operational life of gas turbines.

To accomplish this goal, it is crucial to develop a systematic method that includes well-defined steps. The specific aims of this study are as follows:

1. **Develop a Machine Learning Model to Represent a Healthy Gas Turbine:** This first objective is to create a robust machine learning model that accurately represents the baseline health of a gas turbine. This model will serve as a benchmark for identifying the healthy conditions of gas turbines corresponding to different operational settings and environmental conditions. By inputting various operational settings and environmental conditions, the model will generate covariates that are less influenced by external factors and more reflective of the turbine's true degradation condition. These covariates will be crucial for improving the accuracy of the Cox model.
2. **Propose an Improved Cox Proportional Hazards Model:** Building on the machine learning-generated covariates, the next step is to propose an enhanced Cox model. This model will incorporate a selected baseline hazard function and selected covariates that more accurately represent the underlying degradation processes. The goal is to produce a reliability analysis curve that offers a more precise prediction of failure times, taking into account the complex interplay between operational settings, environmental conditions, and turbine degradation.
3. **Validate the Proposed Method Through Comparative Analysis:** The final objective is to validate the effectiveness of the proposed method by conducting a comprehensive case study. This case study will compare the reliability analysis results of the improved Cox model with those obtained from the traditional model. Through this comparative analysis, the study aims to demonstrate the superiority of the proposed method in accurately predicting gas turbine reliability under varying operational settings and environmental conditions.

By systematically addressing these objectives, this research seeks to make a significant contribution to the field of reliability engineering, particularly in the context of aviation gas turbines. The outcomes of this study are expected to provide valuable insights that can inform future developments in turbine maintenance practices and reliability assessment methodologies.

1.4 Thesis Structure

This thesis is structured into six chapters as follows:

Chapter 1 introduces the background of gas turbines, emphasizing their wide applications in different industries, the importance of maintaining their reliability and the potential benefits of enhancing the reliability analysis method. The chapter briefly illustrates the rationale behind selecting the Cox model for this study. It also outlines the motivations for proposing a new approach to analyze gas turbine reliability. The chapter concludes with a statement of overview of the thesis structure.

Chapter 2 presents a systematic review of the existing literature using statistical approaches for gas turbine reliability analysis. It thoroughly examines the advancements made in applying the Cox model to reliability analysis, identifying gaps in the current research and areas where further improvements are needed.

Chapter 3 describes the XGBoost (extreme gradient boosting) algorithm and the Cox model, which are the fundamentals of the proposed methodologies employed in this study. The chapter details the analytical equations and computational processes that form the foundation of the proposed method.

Chapter 4 elaborates on the proposed methodology, providing a step-by-step guide to its implementation. It includes a detailed flowchart illustrating the process, from establishing a machine learning model to representing a healthy gas turbine and developing an improved Cox model for reliability analysis. The chapter outlines the procedural steps and technical specifics needed for the proposed method.

Chapter 5 applies the proposed method to model a healthy gas turbine and construct an improved Cox model using the NASA C-MAPSS dataset. This chapter demonstrates the validation process, presenting performance metrics and comparison results that highlight the effectiveness of the proposed approach. The case study serves as a proof of concept, illustrating the competence of the proposed method in improving gas turbine reliability analysis.

Chapter 6 concludes the thesis with a summary of the research findings and discusses the implications of the proposed method. The chapter also offers recommendations for future research directions, suggesting how the methodology could be further refined and applied to other complex systems and multiple failure modes.

2 Literature Review in Reliability Analysis for Gas Turbines

Reliability analysis plays a critical role in ensuring the safe and efficient operation of gas turbines. Over the years, a variety of methods have been employed to analyze the reliability of this complex system. This section systematically reviews these methods, focusing primarily on statistical approaches due to their foundational role in reliability engineering.

To structure the review, statistical-based methods are categorized into three main categories: parametric, non-parametric, and semi-parametric, each offering unique strengths and limitations for handling diverse failure and operational data. Following a review of these three categories, particular attention is given to the semi-parametric Cox model, which has emerged as a robust tool for analyzing gas turbine reliability.

The review then progresses systematically from foundational techniques to the application and evolution of the Cox model, highlighting its adaptability and potential integration with machine learning methods. This structure aims to motivate the use of the Cox model and highlight its capacity to address the complexities of gas turbine reliability analysis in modern engineering contexts.

2.1 Statistical-based Methods

Statistical methods have long been the foundation of reliability analysis, offering structured approaches to model and predict the failure behaviour of complex systems like gas turbines. These methods are essential for predicting the potential failure and understanding how reliable the system will be concerning time. Depending on the nature of the data and the assumptions made, statistical

approaches can be broadly categorized into parametric, non-parametric, and semi-parametric methods.

Each category addresses specific challenges in reliability analysis. Parametric methods rely on predefined failure distributions and are suited for well-characterized systems with consistent failure patterns. Non-parametric methods, by contrast, make minimal assumptions about the underlying failure mechanisms, offering flexibility in scenarios with incomplete or censored data. Semi-parametric methods, exemplified by the Cox model, provide a balance between these extremes, combining the interpretability of parametric models with the flexibility of non-parametric approaches.

The following subsections examine each category in detail, highlighting their methodological frameworks, advantages, and limitations. The discussion sets the stage for identifying gaps in existing approaches and introducing semi-parametric methods, particularly the Cox model, as a powerful tool for gas turbine reliability analysis.

2.1.1 Parametric Method

Parametric methods are foundational in reliability analysis due to their simplicity and mathematical rigour. These methods assume that the failure times of components or systems follow a specific probability distribution, enabling the derivation of key reliability metrics, such as the reliability function and hazard rate, using established statistical formulas.

In the context of gas turbine reliability analysis, parametric methods are particularly effective for systems exhibiting consistent failure patterns. Among these methods, the Weibull distribution and its variants have emerged as the most commonly used approaches, based on the current body of

research and their demonstrated flexibility. The Weibull distribution's ability to model increasing or decreasing failure rates makes it uniquely suited for components that experience wear-out or time-dependent degradation. Variants of the Weibull distribution, such as the three-parameter Weibull model and modified Weibull models [15], [16], have been developed to address specific operational and failure conditions in gas turbines.

This dominance of the Weibull distribution can be attributed to its adaptability in reliability contexts. The two-parameter Weibull distribution [17], with its ability to model constant, increasing, or decreasing hazard rates, has been widely used to evaluate failure behaviours in gas turbines. For example, early studies such as the reliability analysis of compressor disks [18] demonstrated the utility of Weibull statistics in predicting component lifespans based on low-cycle fatigue data. Over time, researchers recognized the need for more sophisticated models, leading to the development of three-parameter and modified Weibull distributions to address complex failure patterns.

Recent advancements further reinforce this adaptability. The three-parameter Weibull model, which includes an additional location parameter, has proven particularly effective in modeling operational reliability in gas turbines, as shown in its application to optimize maintenance strategies and extend equipment service life [16]. Furthermore, the bathtub-shaped failure curve of gas turbines, incorporating the three-parameter Weibull model, provides an intuitive framework for assessing gas turbine reliability across different lifecycle stages [19]. This method effectively captures the transition from early-life failures to wear-out failures, offering practical insights for maintenance planning and reliability improvement. Additionally, the modified Weibull distribution introduced in later studies provides enhanced flexibility for reliability estimation, capturing nuanced failure trends and informing just-in-time maintenance interventions [8]. These

developments highlight how Weibull-based approaches have evolved to address the challenges posed by increasingly complex operational conditions in gas turbines.

One of the main strengths of parametric methods, particularly Weibull distributions, lies in their high interpretability and the relatively straightforward process of parameter estimation using techniques like maximum likelihood estimation and least squares method. These features make Weibull models computationally efficient and widely applicable, even in scenarios with limited or structured datasets. For instance, Weibull models have been instrumental in analyzing turbine reliability in real-world applications, including availability studies in combined cycle power plants [20]. Here, Weibull-based reliability indices were used to identify critical turbine components and guide the implementation of predictive maintenance tasks.

Moreover, Weibull distributions are not confined to a single operational context. They have been applied across diverse turbine components and operational scenarios, such as failure prediction in gas turbine disks [18], lifecycle reliability assessment in oil installations [16], and the analysis of bathtub-shaped failure rates to model distinct lifecycle stages of gas turbines [19]. The ability of Weibull models to adapt to varying operational and environmental conditions makes them indispensable for understanding gas turbine reliability and informing maintenance strategies.

Despite the centrality of Weibull distributions in gas turbine reliability studies, it is important to recognize that other parametric distributions—such as the exponential, lognormal, and log-logistic—may offer a better fit for certain failure behaviours or operational profiles. Adopting multiple parametric models can yield a more comprehensive understanding of component lifespans, ensuring that a single set of assumptions does not overly constrain key reliability metrics. By considering these alternative distributions, researchers can capture a wider range of failure

mechanisms and improve the robustness of their reliability assessments, especially in complex or evolving operational environments.

However, parametric methods have limitations. Their reliance on predefined distributions makes them sensitive to incorrect assumptions about the underlying failure mechanisms. For example, in gas turbines operating under varying loads and environmental conditions, assuming a single failure distribution may oversimplify the actual failure behaviour, as demonstrated by discrepancies in reliability predictions for turbines with distinct operational profiles [20]. In such cases, these methods may fail to capture the heterogeneity and complexity of failure mechanisms.

Given these limitations, alternative approaches such as non-parametric methods can be applied to address the need for greater flexibility in reliability modeling.

2.1.2 Non-parametric Method

Non-parametric methods are a crucial alternative to parametric approaches, offering flexibility by avoiding explicit assumptions about the underlying failure-time distribution. Instead of relying on predefined probability models, these methods derive reliability metrics directly from the data, making them particularly adaptable for survival analysis—especially when the data include censored observations [21], [22]. In gas turbine reliability studies, this flexibility proves essential when limited prior knowledge exists about the precise failure mechanisms or when operational data are frequently interrupted by maintenance activities.

Among non-parametric techniques, the Kaplan-Meier (KM) estimator [22] is commonly used for estimating the reliability function. Its stepwise survival curve accounts for the probability of

survival over time, incorporating censored data in a straightforward manner. Mathematically, the KM estimator is expressed as:

$$\hat{R}(t) = \prod_{t_j \leq t} \frac{n_j - d_j}{n_j} \quad (2.1)$$

where n_j is the number of individuals at risk just before time t_j , and d_j is the number of failures at time t_j [23]. This formulation avoids reliance on any particular failure distribution, making it particularly appealing for complex systems such as gas turbines.

The KM estimator can be employed in a variety of gas turbine contexts, primarily because it accommodates censored observations, such as those generated by maintenance activities that remove components from service before failure. By estimating the reliability function over time, engineers can identify intervals when turbine components become increasingly prone to failure, which in turn informs planned maintenance schedules. In addition, the survival function obtained from KM analysis can be used to predict the risk of engine materials with multiple anomaly types [24]. The KM estimator has proven as a time-driven technique to update the reliability curve of the monitored equipment and demonstrates a more adaptive approach to reliability-based remaining useful life (RUL) prediction [25].

Another important non-parametric technique in reliability studies is the Nelson-Aalen (NA) estimator [21], which centers on the cumulative hazard function rather than the survival function. Its basic formulation can be expressed as:

$$\hat{H}(t) = \sum_{t_j \leq t} \frac{d_j}{n_j} \quad (2.2)$$

where d_j and n_j carry the same the same definitions as in the KM estimator [21]. Since the reliability function $R(t)$ can be related to the cumulative hazard through the expression:

$$R(t) = e^{-\hat{H}(t)} \quad (2.3)$$

The NA estimator offers a complementary view of the same reliability data. Rather than describing the probability of survival directly, it depicts how the total risk of failure accumulates over time.

In gas turbine systems, where component lifetimes may deviate significantly from standard parametric models, the NA estimator can offer valuable insights into how risk evolves. This perspective can be particularly informative when components operate under varying loads or environmental conditions, as the cumulative hazard curve may reveal whether failure risk accelerates under certain regimes. Engineers can use these findings to refine maintenance intervals, prioritize the inspection of parts subjected to higher stress, and compare hazard trajectories across different turbine models or operating modes. Like the KM method, the NA estimator does not assume a specific distribution for the time-to-failure, enhancing its adaptability in scenarios characterized by heterogeneous or limited data.

Although both the Kaplan-Meier and Nelson-Aalen estimators incorporate censored data and bypass assumptions regarding the underlying failure distribution, their methodological focus differs. The KM estimator highlights the proportion of components still functioning at each point in time, providing a direct interpretation of reliability. In contrast, the NA estimator emphasizes the aggregate buildup of failure risk, which can be more intuitive in contexts where understanding the rate at which failures accumulate is crucial. When used together, these two estimators provide

a well-rounded view of survival and hazard patterns in a dataset. The choice between them often depends on analytical priorities: KM is typically preferred for examining survival probabilities, whereas NA proves more useful for evaluating how hazard rates change over time.

Non-parametric methods like KM and NA offer several key advantages in reliability studies involving gas turbines. The most notable of these is their capacity to handle censored data without requiring researchers to hypothesize a specific failure-time distribution. This attribute is particularly valuable in heterogeneous systems, where multiple failure mechanisms may coexist and be influenced by varying operational conditions. Additionally, the methods provide results that can be easily visualized and interpreted in exploratory analyses, making them suitable for preliminary investigations or for contexts in which data are scarce.

Despite these benefits, non-parametric approaches also face limitations. Their descriptive nature can complicate direct comparisons across different systems or the inclusion of multiple covariates since no explicit parametric framework guides the analysis. Moreover, in settings where high-dimensional data are present, these methods may lack the predictive power needed to capture complex interactions among numerous variables. Researchers must therefore carefully weigh the simplicity and flexibility of non-parametric estimators against the potential drawbacks associated with interpreting and extending these findings to broader, more complex scenarios.

To address some of the interpretability and predictive challenges associated with non-parametric approaches, analysts frequently turn to semi-parametric models such as the Cox proportional hazards model. This model combines the adaptability of non-parametric estimators, particularly in modelling baseline hazard functions, with the ability to incorporate covariates in a more structured manner, offering a balanced approach to reliability analysis for systems as complex as gas turbines.

2.1.3 Semi-parametric Method

The semi-parametric method serves as a bridge between parametric and non-parametric approaches, combining the strengths of both to offer greater flexibility and interpretability. Unlike the parametric method, semi-parametric models do not require a predefined form for the baseline hazard function, making them more adaptable to varied data conditions. At the same time, they allow the inclusion of covariates, which is often challenging for purely non-parametric approaches.

The Cox model [26] is the most widely recognized and utilized semi-parametric method in reliability analysis. It assumes that the hazard rate of a system is the product of a baseline hazard function and a frequently utilized exponential term involving covariates. This structure allows the model to capture the influence of external factors, such as operational and environmental variables, on system reliability without making rigid assumptions about the baseline hazard.

In gas turbine reliability analysis, the Cox model has been applied to risk management of fleet, evaluate maintenance schedules and predict RUL [13], [27]. Its flexibility and robustness make it particularly suited for systems operating under diverse and evolving conditions.

A core strength of the Cox model, and of semi-parametric methods generally, lies in their capacity to accommodate complex failure behaviors while allowing for detailed evaluation of key covariates. Additionally, its statistical framework allows for hypothesis testing, facilitating the evaluation of each covariate's significance. These attributes make the Cox model a powerful tool for reliability analyses aimed at isolating the effects of specific operational or environmental factors.

Nevertheless, semi-parametric methods present their own set of limitations. Sufficient data are also required to ensure the robust estimation of covariate effects, and sparse or incomplete datasets may compromise the model's accuracy. Despite these concerns, the Cox model remains a key component of modern reliability engineering, striking a strategic balance between parametric specificity and non-parametric adaptability.

The next section expands on how Cox-based reliability methods can be applied to gas turbines. It examines the evolution of baseline hazard functions, explores advanced approaches to the covariates term, and highlights recent developments in integrating machine learning techniques. The next section offers a comprehensive view of modern Cox-model applications in gas turbine reliability.

2.2 Cox-based Reliability Analysis method for Gas turbines

The Cox model is one of the most influential and widely used methods in reliability analysis, particularly for systems operating under varying conditions. Developed as a semi-parametric approach, the Cox model offers a robust framework for analyzing the relationship between system failure rates and external covariates. This flexibility makes it uniquely suited to complex systems like gas turbines, which often operate in dynamic and diverse environments.

In gas turbine reliability analysis, the Cox model has been extensively applied to capture the effects of operational parameters, environmental conditions, and maintenance practices on system failure behaviour. By estimating hazard ratios, the model enables engineers to identify and quantify the impact of key risk factors, providing valuable insights for decision-making. Over time, the Cox

model has evolved significantly, with advancements addressing its limitations and enhancing its adaptability to modern engineering challenges.

The following subsections explore the key developments in the Cox model that have shaped its application in reliability analysis for gas turbines. These include advancements in modelling the baseline hazard function, improvements in the covariate term, and the integration of machine learning techniques to extend the model's predictive capabilities. Each of these aspects represents a crucial step in tailoring the Cox model to meet the demands of complex reliability problems.

2.2.1 Evolution of the Baseline Hazard Function in the Cox Model

The development of the baseline hazard function in the Cox model has experienced significant advancements, particularly in the context of engineering applications.

Jardine et al. [28] applied the Weibull distribution as the baseline hazard function for the Cox model, focusing specifically on the risk and failure analysis of gas turbines. The Weibull distribution, renowned for its flexibility, can model both increasing and decreasing hazard rates, making it an attractive choice for early applications. Jardine et al. demonstrated the utility of the Weibull proportional hazards model by applying it to real-world failure data from aircraft and marine gas turbines. This model proved effective in capturing the changing failure rates in mechanical systems, particularly in environments where time-to-failure and other operational variables were critical [28].

One of the key strengths of the Weibull distribution, as applied in Jardine's study, is its ability to accommodate different types of failure rates across various stages of a system's operational life. Early failures, which may result from manufacturing defects or installation errors, can be modelled

with a decreasing hazard rate, while wear-out failures—caused by material fatigue or long-term degradation—can be modelled with an increasing hazard rate. This flexibility made the Weibull distribution a suitable choice for engineering reliability studies, where mechanical components experience varying stress and environmental conditions over time.

Subsequent studies have built upon Jardine et al.'s foundational work, seeking to overcome the limitations of the traditional Weibull baseline hazard assumption. One such study directly challenged the 'good-as-new' assumption, which presumes that systems, once repaired, return to their original state of reliability [29]. In many real-world applications, particularly those involving complex systems with multiple interdependent components, this assumption does not hold. An alternative model, known as the 'bad-as-old' framework, acknowledges that systems often retain some level of degradation after an emergency repair.

In this framework, the system's hazard rate is not refreshed by minor repairs, meaning the fundamental reliability does not return to a "good-as-new" state. Instead, the system continues to experience the effects of wear and tear, with the hazard rate only being reset following a more comprehensive, planned overhaul. This 'bad-as-old' model better represents the wear accumulation in systems subjected to intermittent repairs and maintenance, such as industrial machinery and equipment. This regime has been modelled as a non-homogeneous Poisson process, where emergency repairs affect the failure process but does not refresh the hazard rate to its initial state. In their study, they used the Weibull proportional hazards model, incorporating covariates related to operational conditions to refine their failure predictions.

This shift from 'good-as-new' to 'bad-as-old' highlighted the importance of revisiting underlying assumptions in reliability modelling. Systems often do not revert to their original condition after

repairs, making it crucial to account for partial degradation over time. By adapting the hazard rate to more realistically reflect the system's condition post-repair, the 'bad-as-old' model provides a more accurate representation of reliability, particularly in industries where components experience cumulative damage, such as manufacturing, aerospace, and power generation. This model not only provided better predictive accuracy but also laid the groundwork for further research into non-monotonic hazard functions that can more flexibly capture complex degradation patterns in engineering systems.

This extension of the Weibull model to account for bad-as-old failure processes has had significant implications for maintenance strategies, allowing for more realistic planning based on the residual risk of failure even after repairs.

Despite its widespread utilization, the Weibull distribution operates under certain assumptions that can limit its applicability in more complex systems. One notable limitation is its monotonic hazard function, meaning it can only model hazard rates that consistently increase, decrease, or remain constant over time, but not those that fluctuate. The Weibull distribution's hazard function depends on its shape parameter, which dictates the nature of the hazard rate. However, it cannot capture hazard rates that increase and then decrease, or vice versa—common scenarios in real-world engineering systems due to factors like maintenance interventions, wear-in periods, or varying operational conditions. For example, maintenance might temporarily reduce the hazard rate, only for it to rise again later. These non-monotonic behaviours are not well-represented by the Weibull function. As a result, relying solely on the Weibull distribution may not provide the most accurate reliability assessments for systems with fluctuating failure risks. Recognizing these limitations has prompted researchers to explore alternative baseline hazard functions that can better capture the

complex failure behaviours observed in engineering systems. Subsequent studies have moved beyond the Weibull distribution, experimenting with non-monotonic hazard functions and incorporating more sophisticated methods to improve the accuracy and flexibility of failure predictions in dynamic operational environments.

In an effort to enhance the flexibility of the Cox model's baseline hazard function, a non-monotonic log-logistic function is introduced as an alternative to the widely used Weibull function [30]. This modification sought to address the limitations of continuous proportional hazard models, which typically rely on monotonic baseline hazard functions that either increase or decrease over time. The log-logistic function offers greater flexibility by allowing the hazard rate to both rise and fall within the same model, making it especially valuable in systems where failure risks are not constant or linear over time [30].

This log-logistic function has been demonstrated to be particularly useful in scenarios where the risk of failure initially increases but later declines due to maintenance, repair, or operational improvements. This non-monotonic behaviour more accurately reflects real-world systems where failure risks may peak during periods of high stress or usage, only to subside after interventions are implemented. By allowing the hazard rate to follow this natural ebb and flow, the log-logistic function offers a more realistic depiction of systems where wear, fatigue, and repairs interact dynamically over time.

The use of the log-logistic baseline hazard function also provides advantages in computational efficiency and model fitting. Compared to the Weibull function, the log-logistic function can better handle variations in failure data that involve both early-life failures and late-life wear-out failures, particularly when dealing with heterogeneous datasets. This flexibility is particularly important in

engineering reliability studies, where the ability to model varying failure rates over a system's operational life is crucial for accurate failure predictions and maintenance scheduling.

The introduction of the log-logistic function into the Cox model highlights the need for models that can adapt to non-linear failure patterns, challenging the traditional assumption that failure rates always follow a monotonic progression. By incorporating the log-logistic function into the Cox model, a tool for more nuanced and adaptable reliability assessments was developed, particularly in environments where systems experience regular maintenance or where operating conditions fluctuate significantly over time.

This advancement in baseline hazard modelling is part of a broader trend toward developing more flexible and responsive hazard models that can accommodate the complex realities of modern engineering systems. The log-logistic function's ability to capture non-monotonic hazard rates marks a step forward in the evolution of parametric hazard models, enabling more precise and effective risk management strategies in industries where system reliability is critical.

Building on the developments in the flexibility of baseline hazard functions, an advanced software package is introduced that allows users to define their own baseline hazard functions within the Cox proportional hazards framework [31]. This innovation was a crucial step forward in enabling more tailored applications of parametric survival analysis. Traditionally, the Cox model has been limited by pre-defined hazard functions such as the Weibull distribution, which may not always capture the complex hazard dynamics present in many real-world scenarios. This Stata software package, `stgenreg`, offered a solution by providing a flexible framework for the specification of user-defined hazard functions, allowing greater customization based on the specific needs of the analysis at hand [31].

The introduction of `stgenreg` represented a turning point for researchers and engineers working in fields where standard parametric models were insufficiently flexible to represent the observed hazard functions. The software allowed users to go beyond traditional models by incorporating spline-based methods, fractional polynomials, and other complex time-dependent effects into their hazard function formulations. For example, users could define a baseline hazard function using restricted cubic splines, offering a smooth, flexible curve that better fits survival data in many engineering and medical applications. This capability made it possible to model hazard rates that exhibit non-linear trends, such as those that rise and fall due to operational interventions or environmental changes, a feature previously challenging to implement in standard software packages.

Additionally, the package supports numerical integration for complex hazard functions, ensuring that even analytically intractable models can be efficiently estimated. This advancement opened up new possibilities for parametric survival analysis, allowing for the application of customized hazard functions tailored to unique datasets. For instance, engineers analyzing the reliability of systems subject to fluctuating operational conditions could define hazard functions that account for multiple, time-varying covariates, leading to more accurate predictions of system failures.

The customizable nature of `stgenreg` thus marked a pivotal moment in the accessibility and applicability of complex reliability models. Researchers could now adapt their models to specific applications, ensuring that the unique characteristics of the systems under study—whether they be mechanical components, environmental conditions, or human health outcomes—were adequately reflected in the hazard function. This level of customization provided a more precise tool for failure

prediction and risk assessment, extending the utility of the Cox model across a broader range of engineering and medical fields.

Further contributions have been made to enhance the Cox model's ability to account for systems with multiple failure modes. The Mixture Weibull Proportional Hazards Model (MWPHM) was introduced and developed to predict failures and analyze the reliability of mechanical systems that exhibit diverse failure behaviours [32]. The model leverages the Weibull distribution to represent the failure rates of individual components, combining multiple failure modes into a comprehensive system-level failure model. By utilizing a mixture model, the MWPHM addresses the complexities of mechanical systems where different components may fail at different rates and through distinct processes, such as wear, fatigue, or material failure.

The MWPHM's effectiveness is further demonstrated by applying it to high-pressure water descaling pumps, which operate under extreme conditions and exhibit two primary failure modes: sealing ring wear and thrust bearing damage. Through the integration of historical lifetime data and real-time monitoring information, the model was able to accurately predict failures across these modes, outperforming traditional single-mode Weibull models. The mixture model captured the interactions and competition between these failure modes, providing a more detailed and realistic assessment of the system's overall reliability.

One of the key advantages of the MWPHM is its ability to account for the simultaneous impact of multiple failure modes, allowing for more accurate failure predictions in complex, real-world systems. The MWPHM not only estimates system reliability based on individual component behaviours but also incorporates the effects of monitoring variables, ensuring that maintenance strategies can be better aligned with actual system conditions. This model provides a significant

improvement in failure prediction accuracy, particularly for systems with interacting failure mechanisms, marking a substantial advancement in reliability analysis for mechanical systems with diverse and competing failure processes.

To further enhance the adaptability of the Cox model's baseline hazard function, a generalized baseline hazard function based on extreme value theory is proposed [33]. This innovative approach was specifically designed to address the extreme environmental conditions that aircraft systems frequently encounter, such as sudden changes in altitude, pressure, and temperature during flight. Traditional baseline hazard functions like the Weibull distribution, while effective for many applications, often fall short when it comes to modelling non-monotonic hazard rates that rise and fall as a result of extreme conditions, such as turbulence or severe weather events. By integrating extreme value theory, this approach enabled the proportional hazards model to more accurately reflect the operational challenges of aviation systems in these high-stress environments.

The generalized baseline hazard function incorporates the flexibility necessary to model these increasing-decreasing hazard rates. This non-monotonic behaviour is crucial in aviation, where the risk of failure can peak during critical moments, such as takeoff or navigating through turbulent airspaces, but may decrease as systems stabilize or as external conditions improve. The extreme value-based hazard function allows for a more precise analysis of aircraft performance and reliability, capturing the dynamic risk profile associated with these operational phases.

Moreover, the proposed model has demonstrated its effectiveness in real-world applications, as it was validated through studies on aircraft performance during turbulence and storm events [33]. By accounting for time-varying covariates, such as atmospheric pressure and temperature, this approach has proven to be a valuable tool in understanding and predicting aircraft system failures

under extreme conditions. The use of this model in predicting the hazard rates during turbulent flights showcases its practical application in improving flight safety and performance monitoring.

This development highlights the growing need for advanced reliability models that can handle the dynamic and extreme conditions typical in modern engineering systems, especially in fields like aeronautics where environmental factors play a critical role in system performance. These advancements not only illustrate the ongoing evolution of the Cox model's baseline hazard function but also emphasize the critical role of covariate modelling in capturing the effects of operational and environmental factors on system reliability.

As a result, exploring the development of the covariate term becomes essential in enhancing the model's predictive capabilities for complex engineering systems. By advancing our understanding of how covariates influence system failure rates, we can further refine the Cox model to provide more accurate and insightful reliability assessments under varying operational conditions.

2.2.2 Advancements in the Covariate Term of the Cox Model

As the baseline hazard function of the Cox model has evolved, advancements have also been made in refining the covariate term, which plays a crucial role in assessing the influence of external factors on system reliability. In engineering applications, covariates often represent operational conditions, material states, or environmental factors, and improvements in handling these covariates have enabled more precise failure predictions and reliability assessments. Several key developments have contributed to the enhanced use of the covariate term, expanding the applicability of the Cox model to more complex and dynamic systems.

A study[34] introduced a development in handling nonlinear relationships between failure rates and state parameters using the Weibull proportional hazards model. This approach addressed the challenge posed by systems where failure rates do not follow simple linear trends but are influenced by complex and evolving state parameters such as temperature, pressure, and vibration. By integrating condition monitoring data with least-squares nonlinear regression techniques, the method allows for real-time prediction of equipment lifetime, providing a dynamic and responsive model that adjusts as new condition data becomes available. This approach proved powerful in real-time health monitoring and predictive maintenance applications, as demonstrated in the application of marine diesel engines. The integration of statistical and data-driven techniques offers a more flexible and accurate tool for assessing RUL in complex engineering systems, as the failure rate trends are continuously updated to reflect the equipment's condition over time. By incorporating nonlinear regression, it provides a robust framework for real-time failure prediction, offering a marked improvement over traditional linear models that may fail to capture the complex interactions between different state parameters and failure mechanisms. This advancement ensures that systems operating under variable conditions can be monitored with greater precision, supporting proactive maintenance strategies and reducing unexpected downtime in critical engineering applications.

In another advancement, Principal Component Analysis (PCA) is employed to extract essential covariate information from large datasets, specifically for the reliability assessment of rotating bearings [14]. The inherent complexity of mechanical systems, such as rolling bearings, often leads to a vast number of operational variables, which can make reliability analysis computationally expensive and less precise when all variables are treated equally. This method recognized the need

to reduce the dimensionality of these datasets while retaining the most critical information for reliability assessment. By applying PCA, this method was able to simplify the covariate structure by selecting only the most representative principal components (PCs) that captured the core variations in the data, thus eliminating redundancies that could obscure the true relationship between operational conditions and failure rates.

The PCA method allowed for isolating the key features that most significantly influenced the system's performance degradation. This approach reduced the dimensionality of the dataset by transforming the original feature set into a smaller number of uncorrelated PCs, which were then used as covariates in the Weibull Proportional Hazards Model (WPHM). The first three PCs were found to capture over 90% of the information necessary to describe the degradation process of the bearings. These PCs were then utilized to predict the RUL and assess the reliability of the bearings with greater accuracy than models relying on unprocessed feature sets.

This technique is valuable in practical engineering applications where large datasets from condition monitoring systems are common. By focusing on the most impactful covariates, the model not only improves predictive accuracy but also reduces computational complexity. This makes the approach more suitable for real-time health monitoring and predictive maintenance, particularly in industries such as manufacturing, energy, and transportation, where equipment reliability is paramount. The PCA-WPHM combination enhances the efficiency and accuracy of the reliability assessment, ensuring that critical maintenance decisions can be made promptly based on the most relevant data.

The further expansion of the scope of the Cox model directly integrates the effects of various working conditions into the exponential term of the model [35]. This approach presents a

generalized model for the reliability assessment of machine tools, a domain where operational conditions such as load, speed, and temperature can significantly impact failure rates. By combining hazard functions with the widely used Weibull distribution, this approach developed a more sophisticated method for accounting for these varying operational stresses, ensuring that the model more accurately reflects the real-world operating environments of machine tools.

The uniqueness of this model is based on its capacity to capture the dynamic interaction between operational conditions and system degradation over time. Machine tools are frequently subjected to fluctuating stresses—such as changes in cutting force, speed, and processing temperature—that can accelerate wear and impact failure mechanisms. The generalized hazard model addresses these challenges by incorporating covariates that directly affect the hazard rate. This method allows for a more detailed and accurate reliability assessment, where the cumulative effect of operational conditions is reflected in the hazard function's exponential term.

The integration of these operational variables into the Cox model enables a more refined analysis of how varying conditions contribute to failure rates. For instance, under high loads and speeds, the wear on critical components is accelerated, leading to increased hazard rates, while under more stable conditions, the hazard rate remains lower. This variability points out the importance of capturing not just static failure rates but also the continuous impact of operational factors over the life of the equipment. By doing so, this model helps in designing better maintenance strategies, ensuring that machine tools are serviced before critical failures occur, thus reducing downtime and extending equipment lifespan. This model is relevant in environments where machine tools are exposed to high levels of operational variability [35]. This methodology also highlights the importance of continuous monitoring and data collection, as it relies on real-time operational data

to adjust the model's predictions dynamically. As a result, this approach offers a more robust framework for predictive maintenance and reliability engineering, ensuring that maintenance decisions are aligned with the actual conditions experienced by the equipment.

Another study advanced the covariate term of the Cox model by incorporating critical environmental factors—such as altitude, ambient temperature, and atmospheric pressure—directly into the exponential function of the model [33]. This development specifically addresses the unique challenges posed by extreme operational conditions in aviation, where environmental stresses can significantly influence system performance. By introducing these covariates, the model provides a more precise representation of the dynamic risks that aircraft face in high-altitude and high-stress environments, particularly during takeoff, landing, and turbulence-prone phases. The study also emphasized the substantial impact of these environmental conditions on aircraft reliability and performance. For instance, the integration of atmospheric pressure, which directly affects engine performance, and altitude, which influences aerodynamic stability, into the Cox model allows for a more realistic and dynamic assessment of failure risks. This model proves essential in aviation safety, as it accounts for the fluctuating nature of these external factors, which are not always captured by traditional reliability models that assume more stable operational environments.

By expanding the covariate term to include environmental variables, the model not only enhances predictive accuracy but also improves the ability to perform real-time risk assessments [33]. This method is crucial in the aviation industry, where the ability to dynamically assess risks based on changing environmental conditions can significantly enhance decision-making related to maintenance and operational safety. As aircraft operate in diverse and often extreme environments,

the inclusion of these covariates ensures that reliability models reflect the real-world conditions that influence system degradation and failure.

A recursive method is tailored and developed to handle systems with large covariate state spaces in the Cox model—a critical advancement for complex engineering applications [36]. This method, specifically designed for health assessment, addresses the challenges of computational efficiency and memory use, which are common issues when dealing with large datasets and real-time system monitoring. The recursive approach proposed continuously updates the hazard function as new covariate data become available. Unlike traditional methods that struggle with the sheer size of covariate state spaces, this approach leverages a discretization technique, breaking down the system age into smaller subintervals and constructing transition matrices over these intervals.

By employing upper and lower bounds for covariate transitions, the recursive method enhances robustness and accuracy, even in complex systems with large state spaces. This technique accounts for uncertainties in covariate changes, ensuring the model remains reliable even when exact covariate values are difficult to determine. This approach ensures that health indices such as the conditional reliability function (CRF) and mean residual life (MRL) are computed efficiently without excessive memory consumption. The recursive formulas derived from the matrix transitions significantly reduce the computational burden compared to traditional matrix-based methods, allowing real-time health monitoring and predictive maintenance in industries like energy and transportation.

It is demonstrated that this method could effectively manage the computational demands of modern prognostics and health management (PHM) systems, where large volumes of operational data are generated continuously. The recursive method optimizes both accuracy and performance,

making it a valuable tool for industries that require fast and reliable health assessments to prevent costly system failures and extend the operational lifespan of critical equipment. This capability is particularly valuable in sectors where equipment failure can have severe consequences, such as in energy production or transportation networks.

These advancements in modelling the covariate term of the Cox model have greatly expanded its utility in engineering domains. They allow for more precise modelling of failure mechanisms and better integration of real-time data. As engineering systems continue to grow in complexity, accurately capturing the effects of operational and environmental covariates becomes crucial for ensuring the reliability and longevity of critical machinery.

However, despite these significant improvements, challenges remain in effectively modelling and analyzing the vast and complex data generated by modern engineering systems. Traditional statistical methods may struggle to capture non-linear relationships and complex patterns within high-dimensional datasets. This limitation has led to a growing interest in integrating machine learning techniques with the Cox model. Machine learning offers powerful tools for handling large-scale data, uncovering hidden patterns, and improving predictive accuracy. In the next section, we explore recent developments that combine machine learning with the Cox model, highlighting how this integration can address current limitations and further enhance reliability analysis in engineering applications.

2.2.3 Integration of Machine Learning with Cox Model

With the rapid advancement of machine learning technologies in the analysis of RUL [37], [38], the Cox model has been further optimized and enhanced in engineering applications. The integration with machine learning methods addresses some of the limitations of traditional Cox

models, particularly in handling complex, high-dimensional, and nonlinear relationships among covariates. Machine learning's ability to process large volumes of data and uncover complex patterns has significantly expanded the Cox model's applicability in modern prognostics and reliability assessments.

One innovative approach involved the development of a deep-learning-based proportional hazards model by integrating a long-short-term memory (LSTM) approach for Time-Between-Failure (TBF) prediction [12]. This method addresses significant challenges in predictive maintenance, such as data sparsity and censoring, which are common in operational maintenance data. By leveraging the LSTM's capacity to capture long-range dependencies and temporal patterns, the model successfully predicted failure times in dynamic systems where failure patterns evolve over time. The LSTM network functions as a covariate processor, feeding its output into the Cox model to provide more accurate RUL predictions. This hybrid approach demonstrated superior performance in handling both censored and uncensored data, particularly in cases where data was sparse or incomplete. The autoencoder component also contributed by converting nominal data into a more robust form, further improving the model's efficiency and accuracy.

The strength of this model lies in its ability to dynamically adjust the hazard rate based on evolving system conditions, allowing for real-time health monitoring. By incorporating deep learning into the traditional Cox model, the study introduced a more flexible and powerful tool for addressing the complex, non-linear relationships among covariates, thus optimizing predictive maintenance strategies. The method was validated using real-world fleet maintenance data, demonstrating notable improvements in model performance metrics such as the Model Correlation Coefficient

(MCC) and Root Mean Square Error (RMSE), which are critical in assessing the accuracy and reliability of failure time predictions.

This work represents a leap forward in combining machine learning with survival analysis techniques, enhancing the Cox model's applicability in modern, data-intensive industries where predictive accuracy is paramount for maintenance and operational efficiency

Another advancement in integrating machine learning with the Cox model involved a data-driven approach that incorporates Geographical Information System (GIS) data through deep learning models [11]. In this method, GIS data—which includes variables such as weather conditions, road characteristics, and traffic patterns—was merged with maintenance records using a deep learning framework to generate health indices (HIs) for vehicles. These health indices served as critical covariates in the Cox model, enabling the estimation of RUL for vehicles operating in diverse geographic environments.

By combining spatial data with historical maintenance information, this method allowed for more context-aware predictions of vehicle health and performance. The inclusion of GIS data enhanced the model's predictive power, particularly in scenarios where operational conditions varied geographically. This integration highlights how machine learning can augment traditional survival models by incorporating diverse data sources, improving RUL estimation accuracy in geographically dispersed systems. Such advancements are particularly valuable for fleet management and transportation systems, where geographical variability plays a crucial role in system degradation and failure rates.

This approach exemplifies the growing trend of blending machine learning techniques with the Cox model to enhance its flexibility and applicability in real-world, data-intensive environments.

By utilizing spatial data, this method expands the model's capacity to make more granular and precise predictions, marking a moving forward in predictive maintenance strategies.

A further refinement in integrating machine learning with survival analysis was the development of a framework combining the Cox model with Random Survival Forests (RSF). This approach was specifically designed to address challenges related to data censoring and dynamic failure rates in systems such as gas transmission pipelines [39]. The RSF model, being a non-parametric ensemble learning method, complements the Cox model by offering greater flexibility in handling censored data. This hybrid framework demonstrated its capability to manage complex, non-linear interactions between covariates, such as pipe diameter, pressure, and wall thickness, which are difficult for traditional Cox models to handle due to their linear assumptions. The hybridization of these two models not only improved the prediction of failure times but also provided a more robust understanding of how various covariates influence pipeline failure probability. This methodological advancement is particularly relevant for systems like pipelines, where censoring is frequent, and the risk of failure varies dynamically based on operational conditions and environmental factors. By leveraging the strengths of both the Cox model and RSF, this combined approach created a more versatile framework capable of adapting to the intricacies of large, real-world systems, thus significantly improving the accuracy and reliability of failure predictions in critical infrastructure systems.

Another advancement in this domain involved the integration of neural networks within the Cox model to incorporate multi-sensor degradation signals into a joint prognostic framework [13]. This approach combines run-to-failure data and real-time IoT-based sensor inputs to create a more nuanced and accurate RUL prediction system for complex systems like gas turbines. By leveraging

neural networks to capture the nonlinear interactions among covariates, the method addresses one of the key limitations of traditional Cox models, which typically struggle with high-dimensional, non-linear datasets.

The strength of this approach lies in its ability to continuously update hazard predictions based on real-time data, improving the responsiveness and accuracy of failure predictions. This model incorporates multiple health covariates derived from sensors monitoring various aspects of system performance. By feeding this real-time sensor data into a neural network within the Cox model framework, the method can dynamically adjust RUL estimates to reflect changing operational conditions, making it particularly useful in industries such as aerospace and energy, where real-time monitoring and precise failure predictions are crucial.

This innovative fusion of neural networks and the Cox model demonstrates how machine learning techniques can expand the model's capabilities to handle complex, evolving datasets, ensuring that the reliability of modern engineering systems is continuously assessed with precision.

These recent studies highlight the growing trend of incorporating machine learning into the Cox model to better handle complex and nonlinear relationships among covariates. By directly using covariate data in sophisticated machine learning architectures, such as deep neural networks and random forests, the Cox model has evolved to meet the demands of modern engineering systems, providing more accurate and real-time reliability analysis and RUL predictions. This fusion marks a crucial advancement in the Cox model's reliability and predictive capabilities, making it a more robust tool for diverse engineering applications. However, while these developments have significantly enhanced the model's applicability, certain challenges specific to aero-gas turbines remain unaddressed.

Despite these advancements, prior research has not sufficiently developed new covariates that accurately capture the unique degradation mechanisms of aviation gas turbines, particularly under their highly dynamic operating and environmental conditions. Existing studies often rely heavily on environmental conditions and operational settings as covariates in reliability analyses. While these factors are important, they can overshadow the intrinsic degradation behaviours of turbine components, leading to less precise reliability assessments. In the context of aviation gas turbines, which operate under rapidly changing loads, temperatures, and pressures, it's crucial to identify covariates that directly reflect component wear and deterioration. Without this focus, the influence of external factors may confound the analysis, hindering the model's ability to provide actionable insights for maintenance and risk management. Therefore, there is a pressing need to develop and incorporate new, more representative covariates that can enhance the Cox model's accuracy in predicting failures and analyzing the reliability of aviation gas turbines, independent of fluctuating environmental and operational conditions.

This research aims to address this gap by developing novel covariates that more accurately represent the degradation processes of aviation gas turbines. By minimizing the influence of external environmental and operational factors, the proposed approach seeks to improve the precision of reliability assessments and provide more effective maintenance strategies.

3 Fundamentals of the Proposed Method

This section introduces key fundamentals behind the Extreme Gradient Boosting (XGBoost) algorithm and the Cox model, both of which are central to the proposed method for gas turbine reliability analysis. These two techniques provide a powerful combination for predicting gas turbine performance and assessing the likelihood of failure under varying working conditions.

XGBoost is a high-performance machine learning algorithm based on gradient boosting, which iteratively builds an ensemble of weak learners—typically decision trees—to improve prediction accuracy. The algorithm’s objective function balances prediction error and model complexity, making it suitable for handling the complex relationships present in gas turbine performance data.

The Cox model is a well-established method for reliability analysis, often used to model the time until a failure event occurs. The Cox model evaluates how covariates, such as environmental and operational conditions, influence the risk of failure over time, without requiring assumptions about the baseline hazard function. This flexibility makes the Cox model a powerful tool for analyzing gas turbine reliability under varying conditions.

The integration of these two techniques—XGBoost for predicting healthy operational parameters and the Cox model for evaluating failure risk—forms the foundation of the proposed reliability analysis method. XGBoost’s ability to capture complex, nonlinear relationships between inputs allows it to model the healthy state of the gas turbine with high accuracy, while the Cox model provides a robust statistical framework for analyzing how deviations from this healthy state affect the turbine’s reliability.

3.1 XGBoost

The Extreme Gradient Boosting (XGBoost) algorithm is renowned for its efficiency and accuracy, particularly in tasks involving structured data. As part of the gradient boosting framework, XGBoost sequentially builds multiple decision trees, where each new tree aims to correct the residuals from the previous ones. This iterative refinement process enhances the model's predictive performance. In the context of this study, XGBoost is essential for predicting gas turbine operational parameters and constructing a healthy gas turbine model across different working conditions.

A key innovation of XGBoost is its use of Taylor Approximation to optimize the objective function. Specifically, the second-order Taylor expansion enables XGBoost to approximate changes in the loss function when adding new decision trees, making the learning process more efficient.

3.1.1 Taylor Approximation

It's essential to first introduce Taylor Approximation for a clearer understanding of how XGBoost makes its updates. This concept is crucial to the way XGBoost iteratively improves the model by adding new trees to reduce errors.

If the function $g(x^*)$ is differentiable, the First-Order Taylor Approximation provides a linear approximation of $g(x^*)$ near x_k . The approximation is expressed as:

$$g(x^*) \approx g(x_k) + g'(x_k)(x^* - x_k) \quad (3.1)$$

This formula represents the linear approximation of a function using the first derivative $g'(x_k)$, which captures the direction of the function's slope at point x_k .

If the function $g(x^*)$ is twice differentiable, the Second-Order Taylor Approximation improves upon the first-order by incorporating the second derivative. This quadratic approximation is expressed as:

$$g(x^*) \approx g(x_k) + g'(x_k)(x^* - x_k) + \frac{1}{2}g''(x_k)(x^* - x_k)^2 \quad (3.2)$$

In this form, the second derivative $g''(x_k)$, also known as the Hessian, accounts for the curvature of the function, providing a more refined approximation by estimating how the function bends at x_k .

XGBoost uses this second-order Taylor Approximation at each iteration to estimate how adding a new decision tree will affect the model's predictions. Unlike traditional gradient boosting methods that only use first-order derivatives (gradients), XGBoost benefits from considering both gradients and Hessians, resulting in more precise and efficient updates.

This approximation allows XGBoost to locally estimate the loss function at each iteration, improving the model's convergence and predictive accuracy. The first derivative (gradient) directs the algorithm towards minimizing the loss function, while the second derivative (Hessian) refines this by adjusting for the curvature. This dual use of gradient and curvature allows for faster convergence and better generalization, especially in complex datasets, such as those encountered in gas turbine performance predictions.

The Taylor expansion applied to XGBoost helps approximate the model's objective function, which includes both a loss function (to measure prediction errors) and a regularization term (to

penalize model complexity). This expansion provides a way for the algorithm to optimize the objective function effectively, minimizing errors and controlling complexity, thus preventing overfitting.

3.1.2 Objective Function

The objective function is a crucial part of the XGBoost algorithm, guiding the model during training to optimize its predictions. The construction of an XGBoost model begins with an initial prediction, and at each iteration, the model adds a new decision tree to correct the residual errors from the previous iteration. This iterative process allows the model to progressively refine its predictions by focusing on the mistakes made in earlier stages.

The objective function in XGBoost has two main components:

1. The loss function: This measures the difference between the actual target values and the predicted values, ensuring that the model minimizes errors as it learns from the data.
2. The regularization term: This penalizes the complexity of the model, encouraging simpler and more interpretable models that generalize better to unseen data. By controlling model complexity, XGBoost avoids overfitting, which is critical in handling large and complex datasets.

Minimizing the objective function involves balancing the trade-off between reducing prediction errors and maintaining model simplicity. The objective function in XGBoost is defined mathematically as follows:

$$L^{(k)} = \sum_{i=1}^n \left[l \left(y_i, \hat{y}_i^{(k-1)} + f_k(x_i) \right) \right] + \sum_{j=1}^{k-1} \Omega(f_j) + \Omega(f_k) \quad (3.3)$$

Where $L^{(k)}$ represents the objective function value at iteration k . This objective function guides the optimization process at each step, aiming to minimize the overall error in the model while applying penalties to limit complexity. n is the total number of training samples in the dataset. Each sample represents a data point used for training the XGBoost model, consisting of input features and the corresponding target values. For each sample i , l is the loss function that quantifies the error between the true target value y_i and the predicted value from the model $\hat{y}_i^{(k-1)}$ at the previous $k-1$ iterations. Specifically, y_i is the actual target value for the i_{th} training sample. $\hat{y}_i^{(k-1)}$ is the predicted value of the i_{th} training sample after the first $k-1$ iterations. $f_k(x_i)$ is the prediction of the new tree being added at iteration k for training sample i . The term $\sum_{j=1}^{k-1} \Omega(f_j)$ represents the regularization terms for the first $k-1$ decision trees. This sum is treated as a constant term during the k_{th} iteration because it only involves trees that have already been constructed. Since these trees are fixed, their contribution to the regularization does not change in subsequent iterations, allowing the algorithm to focus on optimizing the current iteration's tree. $\Omega(f_k)$ is the regularization term for the current tree being constructed at iteration k . This term plays a crucial role in penalizing model complexity, which helps to prevent overfitting. It ensures that the model doesn't become overly complex by discouraging excessively deep or wide decision trees, and promoting more generalizable models.

The regularization terms in XGBoost serve two critical purposes:

1. Preventing overfitting: By penalizing complex models, XGBoost avoids building trees that fit the training data too closely, which would reduce performance on unseen data.

2. Improving model robustness: Regularization helps in constructing trees that generalize well across different datasets and operational conditions, such as those observed in gas turbine reliability data.

By balancing the loss function with the regularization terms, XGBoost minimizes errors while controlling the model's complexity, thus producing a highly accurate, robust model capable of handling complex datasets.

Understanding these key principles of XGBoost is essential for grasping the logic behind the proposed method. Taylor Approximation, particularly the second-order expansion, provides a mathematical basis for optimizing the model by leveraging both gradients and curvatures. This insight into how XGBoost refines predictions iteratively through gradients and Hessians helps illustrate why the algorithm is effective in tasks such as gas turbine reliability analysis, where accurate, high-dimensional data modelling is required. Furthermore, the objective function ensures that the model optimally balances predictive performance and complexity, which is crucial when working with large, complex datasets typically encountered in aviation systems. These fundamentals are directly applied in constructing the proposed method, allowing for precise modelling and more robust reliability predictions.

3.2 Cox Proportional Hazards Model

The Cox proportional hazards model is a semi-parametric model used to investigate the effect of several variables, or covariates, on the time a specified event occurs, such as system failure. This model assumes that the hazard functions among different individuals (in this case, gas turbines)

are proportional, meaning that, regardless of the operational duration of two turbines, the ratio of their failure risks remains constant over time.

In the context of gas turbine reliability analysis, let X_1, X_2, \dots, X_k be the covariates that influence the gas turbine's lifetime, such as operational parameters (e.g., temperature, pressure) or environmental conditions (e.g., altitude, Mach number). These covariates represent important factors that may affect the hazard rate, i.e., the risk of failure over time.

For an individual gas turbine, denoted by i , we can describe its condition at each operational cycle by a covariate vector $\vec{x}_i = (x_{i1}, x_{i2}, \dots, x_{ik})$, where $i = 1, 2, \dots, m$, and each x_{ij} corresponds to the j th covariate value during the i th cycle. This allows us to capture the turbine's operational state throughout its lifespan.

The hazard function for a gas turbine, or the risk of failure at time t given the covariates, is defined as:

$$h(t|\vec{x}_i) = h_0(t) \cdot g(\vec{x}_i) \quad (3.4)$$

In this equation:

- $h_0(t)$ is the baseline hazard function, representing the failure rate when all covariates are zero. This function models the highlighting risk of failure over time, independent of the specific covariates.
- $g(\vec{x}_i)$ is the covariate term, which adjusts the baseline hazard according to the covariates associated with the turbine at cycle i .

In this study, we follow standard practice in the Cox model by employing an exponential function for the covariate term. The exponential function ensures that the hazard function remains positive and allows for the covariates to proportionally increase or decrease the failure risk.

Thus, the covariate term is given by:

$$g(\vec{x}) = \exp(\vec{x}_i \cdot \vec{b}_i) \quad (3.5)$$

Where $\vec{b}_i = (b_{i1}, b_{i2}, \dots, b_{ik})'$ is a vector of coefficients corresponding to the covariates. These coefficients represent the degree to which each covariate influences the failure risk.

By substituting this covariate term into Equation (2), we obtain the following expression for the hazard function:

$$h(t|\vec{x}_i) = h_0(t) \exp\left(\sum_{j=1}^k b_{ij} x_{ij}\right) \quad (3.6)$$

In this expression, the value of each coefficient b_{ij} quantifies the influence of the j_{th} covariate X_{ij} on the hazard function. A positive coefficient $b_{ij} > 0$ indicates that increasing the value of the covariate increases the hazard rate (i.e., a higher risk of failure), while a negative coefficient $b_{ij} < 0$ suggests a protective effect, where higher values of the covariate reduce the risk of failure.

Understanding the fundamentals of the Cox model is crucial. First, these fundamentals lay the foundation for how we model the risk of failure over time based on operational and environmental factors. By defining the hazard function in terms of covariates, we can systematically analyze how different variables, such as gas turbine operating conditions, contribute to the turbine's reliability and failure risk. Furthermore, by incorporating these basic concepts into our proposed method, we

can better assess the effectiveness of improvements, such as the integration of machine learning-generated covariates and an enhanced baseline hazard function. These fundamentals guide the construction of the proposed reliability analysis approach, ensuring that the model is both flexible and robust under varying working conditions.

4 The Proposed Reliability Analysis Method

The proposed method aims to mitigate the effects of fluctuating operational settings and varying environmental conditions on the reliability of aviation gas turbines. These external factors often introduce variability and uncertainty into reliability assessments, leading to inaccuracies if not properly addressed. By developing more robust models that account for these changes, this method provides a more precise and reliable evaluation of gas turbine performance over time.

The method consists of two primary parts that complement each other. The first part involves developing a machine-learning model to represent a healthy gas turbine. This model uses historical data to establish key operational patterns under healthy conditions, which serve as a baseline for comparing turbine sensor measurements in real-time to develop new covariates.

The second part enhances the traditional Cox model, a commonly used statistical tool for reliability analysis. This enhancement can integrate the developed new covariates, allowing the model to adjust predictions dynamically based on changes in turbine operating conditions. The improved Cox model, shown in Figure 4, enables more accurate assessments of turbine failures, offering a more flexible and comprehensive approach to reliability analysis.

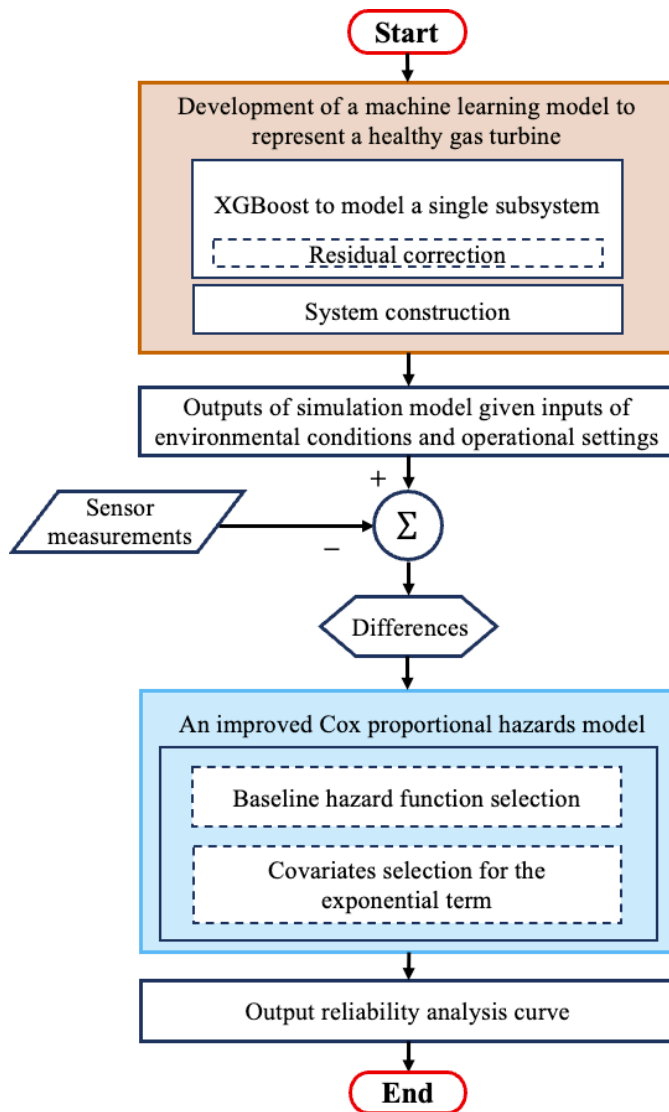

Figure 4. The flowchart of the proposed reliability analysis method

The method begins by developing a machine-learning model to simulate a healthy gas turbine under various environmental and operational conditions. These simulations serve as a benchmark for comparing real-time sensor measurements from turbines in operation. Establishing a baseline of expected behaviour allows for the development of new covariates later in the analysis.

The machine-learning model, built using XGBoost, is chosen for its effectiveness in handling complex relationships in structured data. A key innovation is the introduction of a "residual correction" mechanism, which acts as an error correction feature, refining the model's predictive accuracy by iteratively adjusting the residuals (the difference between predicted and observed values). This mechanism reduces prediction errors and accounts for operational fluctuations, leading to more reliable predictions.

Each subsystem of the turbine is modelled individually, and these subsystems are later integrated into a complete system model. This modular approach ensures greater precision, allowing each subsystem to be fine-tuned before integration. Modelling both individual subsystems and the overall turbine system represents a significant advancement in predicting turbine health. Detailed steps for this process are provided in Section 4.1.

The second part of the method calculates differences by comparing the simulated healthy turbine output with real-time sensor measurements. These differences serve as key indicators of potential degradation or malfunction. By using these residuals as covariates in the reliability model, the method can perform a more robust analysis that isolates the effects of degradation from noise introduced by changing operational and environmental conditions.

This approach improves upon traditional methods, which often use raw sensor data as covariates. Raw data can be heavily influenced by external factors, making it difficult to distinguish between normal fluctuations and early signs of failure. Focusing on the differences between simulated healthy conditions and real-time sensor measurements allows the model to reflect turbine degradation more accurately with minimal interference from external variability. This approach

decouples degradation signals from operational noise, offering a clearer picture of gas turbine health and a significant advantage over traditional methods.

Finally, as another contribution, we develop an enhanced Cox model that incorporates a carefully selected baseline hazard function. This baseline function is chosen to better accommodate the reliability characteristics of aviation gas turbines. In addition to the baseline hazard, the model includes an exponential term of selected covariates derived from differences between healthy operation and failure conditions. These covariates more accurately represent the factors that influence the hazard rate of failure.

By incorporating the developed covariates and the enhanced Cox model, the proposed method dynamically adjusts failure predictions based on the current operational context. This proposed method is specifically tailored to handle variability in working conditions, resulting in more flexible and accurate reliability assessments. The method ultimately generates reliability curves that are not only more accurate but also more representative of real-world turbine behaviour than those produced by the traditional Cox model. These reliability curves provide deeper insights into expected performance and potential failure points, supporting more informed maintenance and operational decisions. Detailed steps for constructing the proposed Cox model are explained in Section 4.2.

4.1 Development of a Machine Learning Model to Represent a Healthy Gas Turbine

An aviation gas turbine is a complex system composed of multiple subsystems, each varying in structure, configuration, and the components it includes. These subsystems can be either standalone units or comprise multiple interconnected components. Modelling each subsystem accurately is essential for predicting the overall health and performance of the gas turbine. In this section, we propose a subsystem model that integrates individual models to represent the healthy operational state of an aviation gas turbine.

To improve prediction accuracy within the subsystem model, we introduce a residual correction mechanism. This mechanism enhances the model's ability to predict critical parameters such as the temperature at the low-pressure turbine outlet and the static pressure at the high-pressure compressor outlet. To achieve this, two distinct XGBoost-based machine-learning models are developed: the Gas Path Predictor (GPP) and the Residual Corrector (RC), as shown in Figure 5. The GPP is responsible for predicting healthy gas path parameters, such as coolant bleed, while the RC reduces the prediction error by correcting the residuals produced by the GPP. This approach results in higher overall accuracy in subsystem predictions, and Figure 5 illustrates the subsystem modelling framework within the gas turbine.

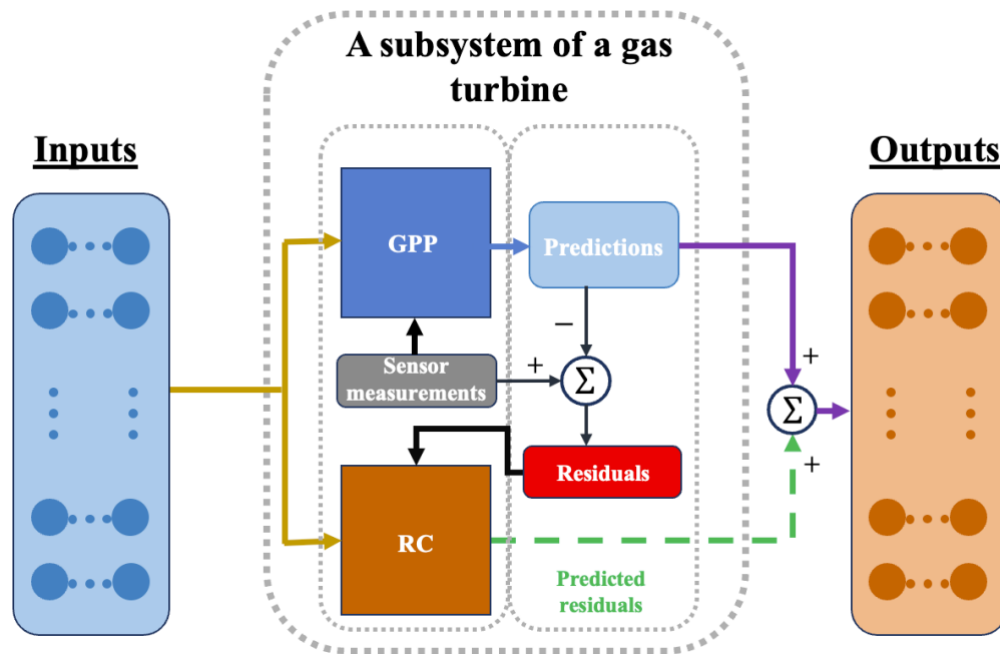

Figure 5. The details of subsystem modelling in a gas turbine

The GPP is trained using sensor data collected from gas turbines, and its inputs and outputs are based on the specific location of the subsystem within the overall turbine system. For subsystems located at the start of the gas turbine, inputs include environmental conditions and operational settings such as altitude and Mach number. Conversely, for subsystems located at intermediate stages, the GPP uses predicted outputs from preceding subsystems as inputs, such as predicted temperature or pressure values. For example, in the combustor subsystem, additional parameters like fuel flow may be incorporated to more accurately depict the combustion process and its effects on subsequent stages.

This modular training approach ensures that each subsystem's GPP is tailored to the conditions and data relevant to its position in the turbine system, thereby improving the model's prediction accuracy for each specific subsystem. By training each GPP in this way, we can simulate the operational characteristics of each subsystem in a healthy turbine with greater precision.

Once the GPP generates predictions for a subsystem, these predictions are compared to actual sensor measurements from the turbine, and the difference between the predicted and measured values is calculated as the residual. These residuals are then used as output for the training of the RC model. The RC model's inputs are identical to those used by the GPP, such as environmental factors, working conditions, or the predicted outputs from preceding subsystems. After the RC model is trained, it predicts residuals based on these inputs.

In the final step, the GPP's predictions and the predicted residuals from the RC are combined to form the final output of the subsystem model. This residual correction mechanism ensures that minor errors in the GPP's predictions are corrected, resulting in more accurate and reliable outputs for each subsystem.

The steps involved in modelling each subsystem within the proposed reliability analysis method can be summarized as follows:

Step 1: Establishment of XGBoost-based GPP

The first step in modelling the subsystem involves establishing the XGBoost-based Gas Path Predictor (GPP). The inputs and outputs of the GPP model are defined according to the specific structure and location of the subsystem within the gas turbine. For instance, if the GPP is associated with a subsystem at the start of the turbine (such as the compressor), environmental conditions and operational settings, such as altitude and throttle resolver angle (TRA), serve as inputs. These inputs influence key operational parameters, including temperature and pressure, which are defined as outputs. These outputs establish the mapping relationship between the subsystem's inputs and outputs, forming the foundation for predicting subsystem behaviour.

To optimize the XGBoost model, we employ GridSearchCV, a widely used hyperparameter tuning technique. GridSearchCV systematically searches through all possible combinations of hyperparameters, such as the learning rate, number of estimators, and maximum depth of trees, to find the most effective settings for the model. This optimization ensures that the GPP can make the most accurate predictions possible based on the available data.

To evaluate the performance of the GPP, we use Mean Absolute Percentage Error (MAPE). MAPE is particularly well-suited to this application because sensor measurement ranges can vary significantly. By normalizing errors relative to actual sensor values, MAPE allows for a more intuitive interpretation and comparison of prediction accuracy across different scales. This metric is invaluable for ensuring that the GPP produces reliable predictions, regardless of the magnitude of the sensor data being used.

Step 2: Construction of XGBoost-based RC

Once the GPP has been established, the next step is to construct the Residual Corrector (RC) model. The RC is tasked with refining the predictions made by the GPP by correcting residuals—errors that arise when comparing the GPP’s predictions to actual sensor measurements.

To train the RC, we use the same inputs as the GPP model (e.g., environmental conditions or preceding subsystem outputs), along with the residuals from the GPP’s predictions. These residuals are calculated as the difference between the GPP’s predicted outputs and the actual sensor measurements.

Similar to the GPP model, the RC is optimized using GridSearchCV, and its performance is evaluated using MAPE. This consistent approach ensures that both models are fine-tuned to

minimize prediction errors and achieve the highest level of accuracy. The RC's role in the subsystem model is crucial, as it corrects the GPP's prediction errors and improves the overall reliability of the subsystem predictions.

Step 3: Generating a More Accurate Subsystem Output

The final step in modelling the subsystem is to combine the predictions from the GPP with the predicted residuals from the RC. By adding the residuals to the GPP's predictions, the model effectively offsets the errors from the GPP and generates a more accurate output for the subsystem. This combined output reflects a more precise representation of the subsystem's behaviour under healthy operating conditions.

To ensure that the model produces accurate predictions, we once again evaluate its performance using MAPE. This continuous evaluation process helps to maintain high prediction accuracy, ensuring that the subsystem model is reliable and robust.

This method of combining the GPP's predictions with the RC's residuals results in improved prediction accuracy, and it forms the building block for the overall gas turbine model. By modelling each subsystem in this way, we can ensure that the final model of the gas turbine accurately represents the healthy operation of all subsystems.

Once all subsystems within a gas turbine have been modelled using this approach, they are connected to construct the complete machine-learning model of a healthy gas turbine. Each subsystem, represented by its own GPP and RC models, contributes to the overall prediction accuracy of the gas turbine's behaviour. This integrated model serves as the foundation for performing reliability analysis and assessing the health of gas turbines.

Finally, a case study demonstrating the application of this subsystem modelling approach and the corresponding validation process is provided in Section 5.2.1. This case study highlights the effectiveness of the proposed method in accurately predicting the health and performance of a gas turbine under various operational settings and working conditions.

4.2 An Improved Cox Proportional Hazards Model

The improved Cox model plays a critical role in enhancing the accuracy of reliability analysis within our proposed method. As discussed in Section 3.2, the Cox model consists of two key components: the baseline hazard function and the exponential term that incorporates covariates. While the mathematical framework of the traditional Cox model has been well established, our approach introduces specific enhancements to better handle the complexities of gas turbine reliability under varying operational conditions.

In this section, we provide a detailed explanation of the process used to construct the improved Cox model. This process includes two major steps: the selection of the baseline hazard function and the selection and estimation of covariates for the exponential term. The steps of the process are outlined in the flowchart in Figure 6.

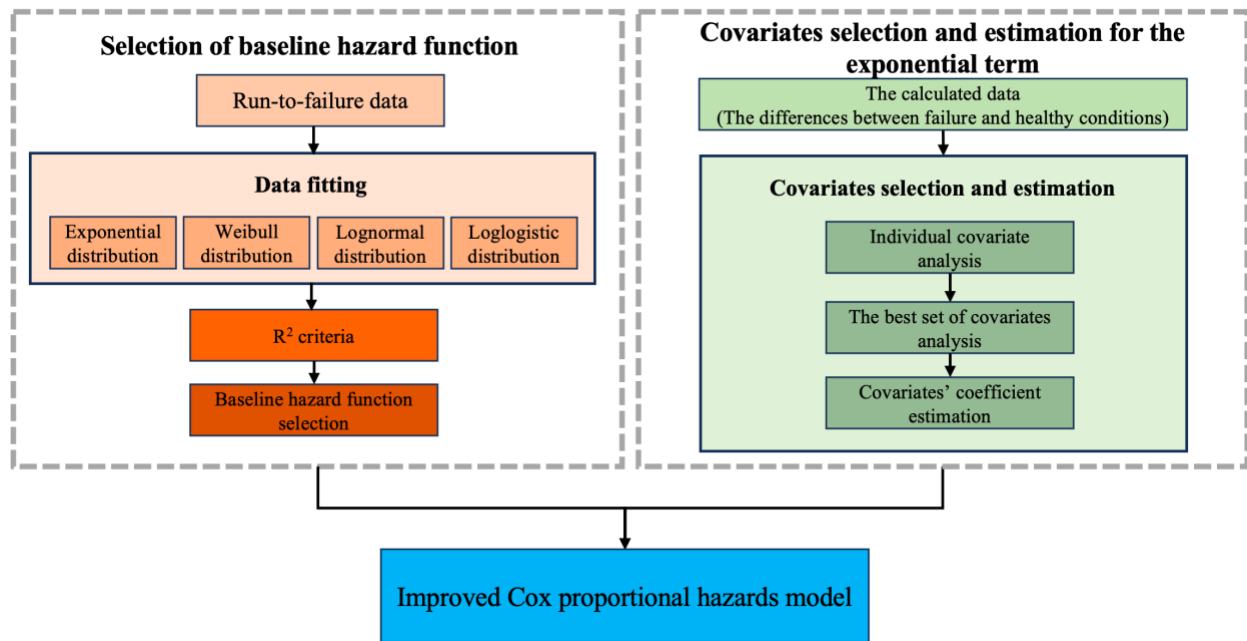

Figure 6. Flow chart of establishing an improved Cox proportional hazards model

Step 1: Selection of the Baseline Hazard Function

The baseline hazard function represents the hazard rate for a turbine operating under baseline conditions, without the influence of covariates. Selecting the appropriate baseline hazard function is essential because it sets the foundation for accurate risk prediction.

To select the baseline hazard function, we employed run-to-failure data, which provides a complete picture of turbine failures over time. Four commonly used failure distributions are considered for fitting the data, including the Exponential, Weibull, Lognormal, and Loglogistic distributions. A cumulative hazard plot method is employed for a graphical evaluation of the data, helping to visually assess the appropriate distribution. This method is useful because it allows us to evaluate how well the selected distribution fits the data by plotting cumulative hazards over time.

We quantitatively evaluate the fit of each distribution using the R^2 criterion, which provides a measure of how closely the chosen distribution matches the run-to-failure data. The distribution with the highest R^2 score is selected as the baseline hazard function for the Cox model, ensuring that the model accurately represents the time-to-failure characteristics of the gas turbine.

After selecting the best-fitting distribution, we further use the cumulative hazard plot method to estimate the parameters of the baseline hazard function. In this step, a linear regression approach is applied to the cumulative hazard plot. The slope and intercept of the linearized plot correspond to the estimated parameters of the selected baseline distribution. This graphical method simplifies the parameter estimation process by offering both a visual and quantitative evaluation of the distribution's fit, ensuring an accurate baseline hazard function for the improved Cox model.

Step 2: Covariate Selection and Estimation for the Exponential Term

The second component of the Cox model involves the exponential term, which accounts for the influence of covariates on the hazard rate. These covariates are derived from the differences in gas path parameters between healthy and failure conditions while the gas turbine operates under the same working conditions. The use of these calculated differences allows the model to capture critical operational variables, such as environmental factors, that significantly impact turbine reliability.

To select the covariates for inclusion in the exponential term, we employ the Wald statistical test. This test is used to determine whether each covariate significantly affects the hazard rate. A 5% significance threshold is applied in the selection process, meaning that covariates with a P-value less than 0.05 and a Chi-Square value greater than 3.841 (with one degree of freedom) are

considered significant and included in the model. By applying the Wald test, we ensure that only covariates with a meaningful impact on failure risk are selected for the model.

To avoid overfitting while still accurately modelling the turbine's reliability, we use the Akaike Information Criterion (AIC) to evaluate and compare different Cox models. The AIC balances the trade-off between model fit and complexity by penalizing models with an excessive number of parameters. By minimizing the AIC, we can select the model that best fits the data while maintaining an appropriate level of complexity.

Once the significant covariates are selected, the next step is to estimate their coefficients within the exponential term. This is done using Maximum Likelihood Estimation (MLE), a method that ensures the coefficients are statistically optimized for the given data. To improve the efficiency and convergence speed of the coefficient estimation process, we employ the Newton-Raphson procedure, which is particularly effective when handling large datasets, such as those used in gas turbine reliability analysis.

Step 3: Combining the Baseline Hazard Function with the Exponential Term

Finally, the selected baseline hazard function is combined with the exponential term, which includes the selected covariates, and their estimated coefficients based on the calculated dataset. This results in the construction of the improved Cox model. The computational procedures to obtain the Cox model were thoroughly discussed in Section 3.2. It provided a detailed breakdown of the mathematical formulation of the Cox model, such as the hazard function. Building on the foundations presented in Section 3.2, we now extend the model by integrating both the baseline hazard function and the exponential term. The reliability function of the Cox model can be expressed as follows:

$$R(t|\vec{x}_i) = R_0(t) \exp(\sum_{j=1}^k b_{ij}x_{ij}) \quad (4.1)$$

where $R_0(t)$ represents the baseline reliability function, and $R(t|\vec{x}_i)$ denotes the reliability function of the improved Cox model. This function forms the basis for performing reliability analysis, as it accounts for both baseline failure risks and the effects of covariates on those risks. This combined model offers a powerful tool for predicting gas turbine reliability and dynamically adjusting reliability assessments based on real-time operational data.

The construction of the improved Cox model and the validation for the proposed reliability analysis method are further detailed in Section 5.2.2.

5 Validations Using NASA C-MAPSS Data

This section provides validation of the proposed method using the NASA Commercial Modular Aero-Propulsion System Simulation (C-MAPSS) dataset, which is widely recognized for its comprehensive representation of gas turbine degradation under varying operational conditions. The C-MAPSS dataset allows us to rigorously evaluate the performance of the proposed machine-learning model and the improved Cox model, ensuring that they can accurately predict gas turbine reliability and degradation patterns.

Section 5.1 provides a brief overview of the C-MAPSS dataset, detailing the operational settings and gas path parameters available. Subsequently, Section 5.2 presents the implementation of the proposed method using the C-MAPSS data, including the process of modelling a gas turbine following the procedures outlined in Section 4, and the construction and validation of the improved Cox model.

5.1 Description of the Data

In this study, the NASA C-MAPSS degradation dataset is employed to model and validate the proposed reliability analysis method. The dataset consists of simulated degradation data for commercial aero engines under a variety of environmental and operational conditions, providing an ideal testbed for assessing the accuracy of our models.

The dataset includes three key operational settings:

1. Altitude – representing the operational altitude of the gas turbine.
2. Mach Number – indicating the turbine's speed relative to the speed of sound.

3. Throttle Resolver Angle (TRA) – reflecting the level of throttle input during operation.

In addition to the operational settings, the C-MAPSS dataset provides twenty-one sensor measurements related to gas turbine performance, such as temperature, pressure, and other gas path parameters. These sensor readings offer a detailed picture of the turbine's behaviour under various operational conditions and are crucial for both training the machine-learning models and validating the performance of the proposed reliability analysis method.

Table 1 presents the list of twenty-one sensor measurements and provides brief descriptions of each parameter, ensuring clarity in understanding the variables involved in modelling gas turbine degradation.

Table 1. Description of sensor measurements in C-MAPSS data [40]

Brief description	Sensor measurement
Temperature at inlet of the fan	T_2
Temperature at outlet of the LPC	T_{24}
Temperature at outlet of the HPC	T_{30}
Temperature at outlet of the LPT	T_{50}
Pressure at inlet of the fan	P_2
Total pressure across bypass section	P_{15}
Total pressure at outlet of the HPC	P_{30}
Fan speed - physical	N_f
Core speed - physical	N_c
Pressure ratio of the engine (P50/P2)	Epr
Static pressure at outlet of the HPC	P_{S30}

Ratio of fuel flow to static pressure at outlet of the HPC	Φ
Fan speed - corrected	NR_f
Core speed - corrected	NR_c
Bypass Ratio	BPR
Fuel-air ratio of burner	farB
Bleed Enthalpy	htBleed
Fan speed - demanded	Nf_{dmd}
Corrected fan speed - demanded	$PCNfR_{dmd}$
Coolant bleed at HPT	W_{31}
Coolant bleed at LPT	W_{32}

The C-MAPSS data includes FD001, FD002, FD003 and FD004 subsets. Each subset has a training set, a test set, and a RUL set. All the training sets consist of multiple engines operating from healthy conditions to system failure. However, in the testing dataset, the acquisition of operational conditions and sensor measurements right censored before a failure occurs. The corresponding RULs of each gas turbine in the testing dataset are provided for the validation of the proposed approach.

FD001 and FD002 include one failure mode, HPC degradation. FD003 and FD004 include two failure modes, HPC degradation and fan degradation, which show a more complex scenario. This study is limited to one failure mode. Therefore, FD001 and FD002 were selected for this research. Table 2 describes the FD001 and FD002 subsets, including the number of gas turbines in each subset's training, testing and RUL set, failure modes and flight conditions.

Table 2. Summary of FD001 and FD002 subsets

Name of dataset	Division of dataset	Number of gas turbines	Failure mode	Flight condition(s)	
FD001	Train	100	HPC Degradation	One set of Altitude, TRA and Mach number	
	Test	100			
	RUL	100			
FD002	Train	260		HPC Degradation	Six sets of Altitude, TRA and Mach number
	Test	259			
	RUL	259			

As shown in Table 2, the FD001 subset consists of data from gas turbines operating under a single flight condition, while the FD002 subset contains data from gas turbines operating under six different flight conditions. These subsets offer varying levels of complexity, with FD002 providing a more comprehensive dataset due to the additional flight conditions.

The primary objective of this research is to validate the performance of the proposed reliability analysis method across different working conditions. Therefore, the entire FD002 subset is employed to build the healthy gas turbine model and validate the method under multiple operational scenarios. FD002 is particularly suitable for this purpose because it includes one failure mode (HPC degradation) and spans six flight conditions, thus enabling a robust assessment of how the proposed method adapts to different environmental and operational settings.

In addition to the FD002 subset, five gas turbines are randomly selected from the test set of the FD001 subset to further evaluate the performance of the proposed method. These additional test cases serve as a means of validating the method's adaptability and generalization capabilities, as FD001 operates under a different flight condition from FD002. By incorporating gas turbines from

both subsets, this study ensures that the proposed method is thoroughly tested under a variety of operational conditions, making the findings more robust and comprehensive.

5.2 Implementations of the Proposed Method and Validations

5.2.1 Gas Turbine Modelling and Validation

To construct an accurate model of the gas turbine, the system is first divided into two subsystems based on the cold and hot regions of the turbine. This division is consistent with the physical structure and operational characteristics of gas turbines and allows for more detailed and precise modelling of the turbine's behaviour. The rationale behind this division is based on the distinct roles that these regions play in the overall functioning of the turbine. The layout of the simulation gas turbine model, showing the various components and their connections based on the NASA data, is illustrated in Figure 7 [40].

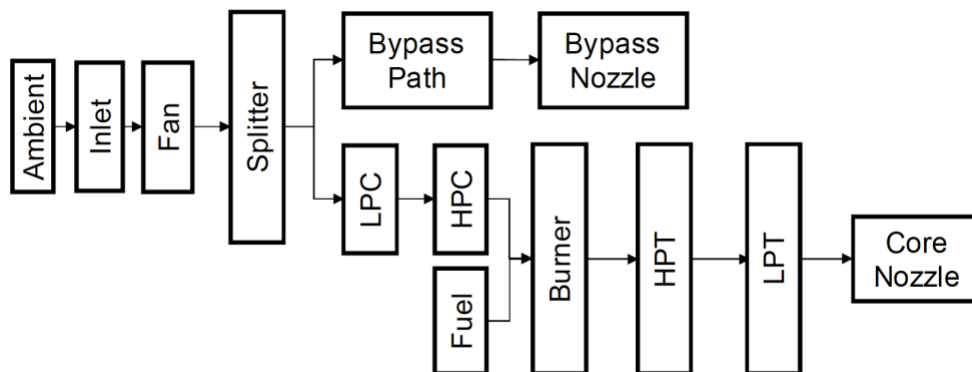

Figure 7. The layout of the simulation model with various components connected

Subsystem 1 represents the cold area of the turbine, which primarily involves the intake and initial compression of air. The key components of this subsystem include the inlet, fan, splitter, low-pressure compressor (LPC), and high-pressure compressor (HPC). These components work

together to intake air, manage its initial compression, and direct it through the appropriate flow paths (either bypass or into the core compressor). The air processed in this subsystem is then sent to the next stage of the system for further compression and combustion preparation.

Subsystem 2 represents the hot area of the turbine, which is where fuel combustion and power generation occur. The key components of this subsystem include the burner, high-pressure turbine (HPT), and low-pressure turbine (LPT). After the air has been compressed by the HPC, fuel is injected, and combustion takes place in the burner. The resulting high-energy gases are used to drive both the HPT and LPT, which contribute to power generation and thrust. The core nozzle and bypass nozzle handle the expulsion of exhaust gases.

In addition to these structural divisions, the model incorporates three operational conditions and twenty-one sensor measurements from the C-MAPSS dataset, which are essential for capturing the turbine's behaviour under different working scenarios. The three operational conditions—altitude, Mach number, and throttle resolver angle (TRA)—define the environmental and operational settings under which the turbine operates. The sensor measurements, which include parameters such as temperature and pressure across various parts of the turbine, provide real-time data for evaluating the turbine's performance.

These operational conditions and sensor measurements are applied to both subsystems, allowing the model to simulate the entire gas turbine system under different operational scenarios. This two-subsystem structure, as illustrated in Figure 8, ensures that each part of the turbine is modelled with appropriate granularity, reflecting its unique operational characteristics. The division also facilitates more accurate predictions of turbine behaviour, as the cold and hot areas can be modelled and analyzed separately before integrating them into the overall turbine model.

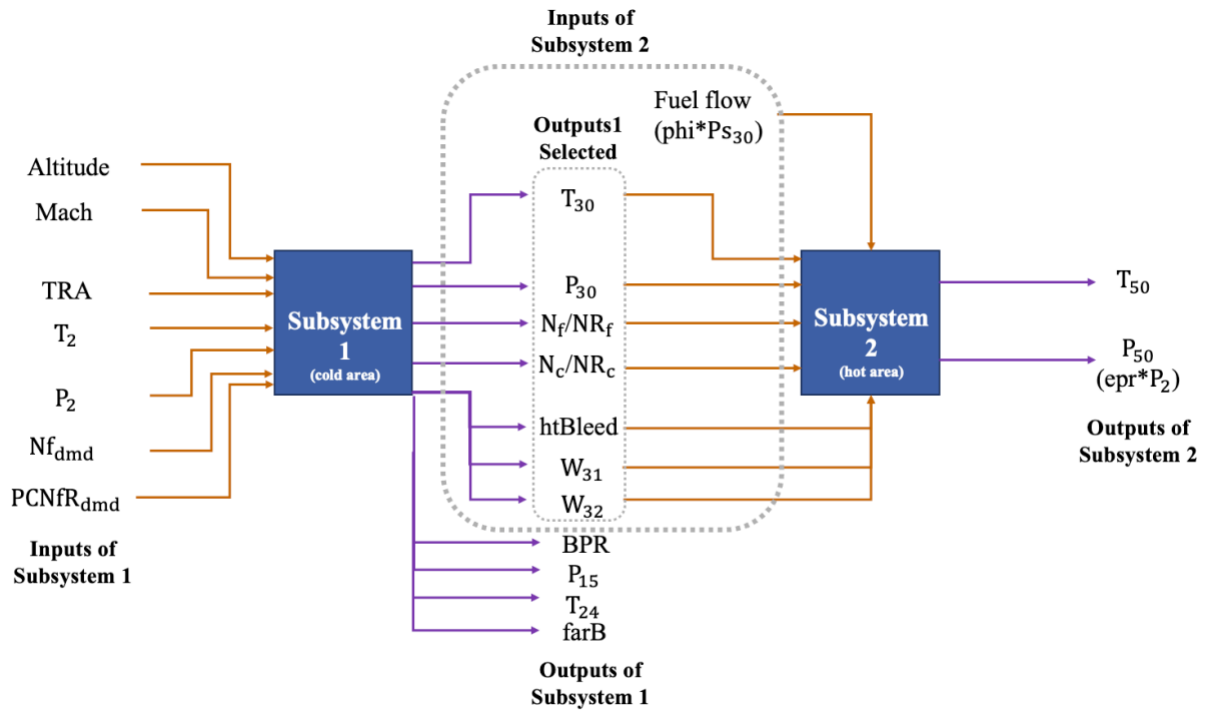

Figure 8. Gas turbine system modelling using the C-MAPSS dataset.

Altitude, Mach number, and throttle resolver angle (TRA) serve as the operational inputs for Subsystem 1. Additionally, sensor measurements such as T_2 (the temperature at the inlet), P_2 (the pressure at the inlet), Nf_{dmd} (fan speed demand), and $PCNfR_{dmd}$ (fan speed ratio demand) are incorporated as further inputs. These inputs collectively represent the environmental and operational settings under which Subsystem 1 functions, ensuring the model accurately captures the conditions affecting the intake and compression processes.

For Subsystem 2, the key outputs include T_{50} (the temperature at the high-pressure turbine outlet) and P_{50} (the pressure at the high-pressure turbine outlet). Importantly, P_{50} is generated using the engine pressure ratio (Epr) and P_2 before the model training stage. These outputs are critical as they reflect the conditions under which combustion and power generation occur within the hot area of the turbine.

To model the fuel flow within Subsystem 2, ϕ (the air-to-fuel ratio) and $P_{S_{30}}$ (the pressure at the high-pressure compressor outlet) are used. These parameters are essential for calculating fuel flow, which is incorporated as an additional input for Subsystem 2 to account for the fuel-air mixture in the burner and its impact on the combustion process. The inclusion of fuel flow as an input allows for a more accurate representation of the energy conversion process in the burner.

Apart from the operational conditions and key sensor measurements described, the remaining sensor measurements are used as outputs for Subsystem 1. The outputs for Subsystem 1 include important sensor readings such as T_{30} (the temperature at the high-pressure compressor outlet), P_{30} (the pressure at the high-pressure compressor outlet), N_f (fan speed), NR_f (corrected fan speed), N_c (core speed), NR_c (corrected core speed), htBleed (bleed flow), W_{31} (mass flow at the high-pressure compressor exit), and W_{32} (mass flow at the high-pressure turbine inlet). These measurements capture the turbine's performance in the cold area and provide the necessary inputs for Subsystem 2.

The inputs for Subsystem 2 include T_{30} , P_{30} , N_f , NR_f , N_c , NR_c , htBleed, W_{31} , and W_{32} . These parameters represent the operational state of the turbine as it transitions from the cold to the hot area, and they are identified as informative sensor measurements based on previous studies [29][30]. By selecting these inputs, Subsystem 2 is equipped with the necessary data to model the combustion and energy generation processes with higher accuracy.

Once the inputs and outputs for both subsystems are defined and configured based on the NASA C-MAPSS data, Subsystem 1 and Subsystem 2 are connected to form a complete healthy gas turbine model. This integrated model allows for an accurate simulation of gas turbine performance, capturing both the cold and hot areas of the turbine and enabling detailed reliability analysis.

The performance of the two subsystem models is validated using the healthy gas turbine model created with the NASA C-MAPSS dataset. To evaluate the accuracy of each subsystem model, we compare their performance to that of the corresponding Gas Path Predictor (GPP) model, using the Mean Absolute Percentage Error (MAPE) as the evaluation metric. As outlined in Section 4.1, the GPP is the primary machine-learning model developed to predict the healthy gas path parameters for each subsystem. However, while the GPP is capable of generating initial predictions, it may not capture all the subtle patterns and complexities present in the data, resulting in prediction errors.

To address these potential inaccuracies, the proposed subsystem model incorporates a residual correction mechanism aimed at enhancing the GPP's predictions by correcting the residual errors. This correction process improves the overall accuracy of the predictive performance for each subsystem model, ensuring that the final outputs are more reliable.

The MAPE of the proposed Subsystem Model 1's outputs is 0.18630%, while the MAPE of the corresponding GPP's predictions is 0.19565%. This indicates that Subsystem Model 1 achieves a 4.78% improvement in MAPE over the GPP. Although this improvement is modest, it demonstrates the residual correction mechanism's effectiveness in fine-tuning the predictions for the cold area of the gas turbine.

In contrast, the MAPE of the proposed Subsystem Model 2's outputs is 0.17336%, whereas the MAPE of its corresponding GPP's predictions is significantly higher at 0.37938%. This represents a substantial 54.3% performance improvement in MAPE over the GPP for Subsystem 2. The marked difference in performance between Subsystem Model 1 and Subsystem Model 2 highlights

the effectiveness of the residual correction mechanism, particularly in the hot area of the turbine where more complex and dynamic processes occur, such as fuel combustion and power generation. Table 3 summarizes these findings, clearly showing that the proposed subsystem models consistently outperform their GPP counterparts. The performance enhancement is especially pronounced in subsystems that are located at intermediate or final positions within the gas turbine, as these subsystems are more susceptible to accumulated prediction errors due to the complexity of the processes involved.

Table 3. Validation of the modelled healthy gas turbine using FD002 subset

Subset	Subsystem	Evaluation metrics	GPP	The proposed subsystem model	Performance improvement
FD002	1	MAPE	0.19565%	0.1863%	4.78%
	2	MAPE	0.37938%	0.17336%	54.3%

The significant improvement in Subsystem Model 2's performance over Subsystem Model 1 can be attributed to the cumulative effect of the residual correction mechanism. In this modelling approach, the residual-corrected output from Subsystem Model 1 is used as an input for Subsystem Model 2. As a result, the error correction introduced by Subsystem Model 2 further refines the prediction performance in downstream subsystems, amplifying the benefits of the correction mechanism. This cascading improvement in accuracy explains why the hot area of the gas turbine, represented by Subsystem 2, sees a more dramatic performance boost compared to the cold area, represented by Subsystem 1.

By applying the residual correction mechanism and validating the models using MAPE metrics, we have demonstrated that the proposed subsystem models are not only more accurate but also

better equipped to handle the complexities of gas turbine operations, particularly in areas involving fuel combustion and power generation.

5.2.2 Construction of an Improved Cox Proportional Hazards Model

This section describes the construction of an improved Cox model using the FD002 subset of the NASA C-MAPSS dataset. The process includes selecting an appropriate baseline hazard function and generating covariates for the exponential term in the model. By optimizing these elements, the Cox model becomes more flexible and better suited to handle the complexity of gas turbine reliability data under varying operational settings and working conditions.

5.2.2.1 Selection of the Baseline Hazard Function

The first step in constructing the Cox model is to select the baseline hazard function, which represents the hazard rate for a turbine operating under baseline conditions, assuming all covariates are at their reference or zero values. In this study, the baseline hazard function is chosen based on a visual assessment using the cumulative hazard plot method and the R^2 score for various failure distributions. This approach ensures that the selected distribution accurately reflects the time-to-failure data from the FD002 subset, which includes gas turbines operating under multiple flight conditions.

As illustrated in Figure 9, Figure 10, Figure 11 and Figure 12, the cumulative hazard plot method is applied to four commonly used failure distributions: the Exponential, Weibull, Lognormal, and Log-logistic distributions. By fitting these distributions to the run-to-failure data, we can determine how well each one captures the inherent failure patterns. The R^2 score for each distribution is calculated to quantitatively assess the fit:

- Log-logistic distribution: $R^2 = 0.978$
- Weibull distribution: $R^2 = 0.891$
- Lognormal distribution: $R^2 = 0.888$
- Exponential distribution: $R^2 = 0.958$

Among these distributions, the Log-logistic distribution achieves the highest R^2 score of 0.978, significantly outperforming the other distributions. Therefore, the Log-logistic distribution is selected as the baseline hazard function for this study. Its superior fit indicates that the Log-logistic distribution effectively captures the characteristics of the failure data, making it an ideal choice for hazard function estimation in the Cox model.

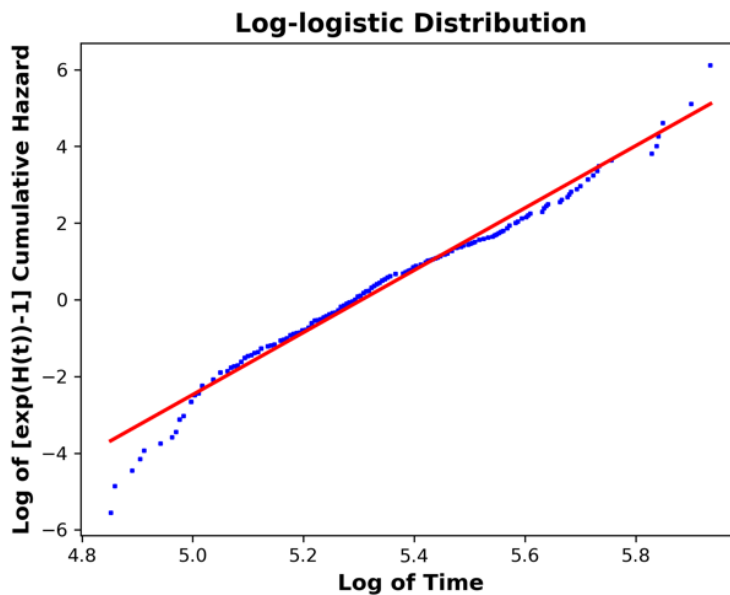

Figure 9. Visualization and selection of commonly used failure distributions (a) Log-logistic distribution

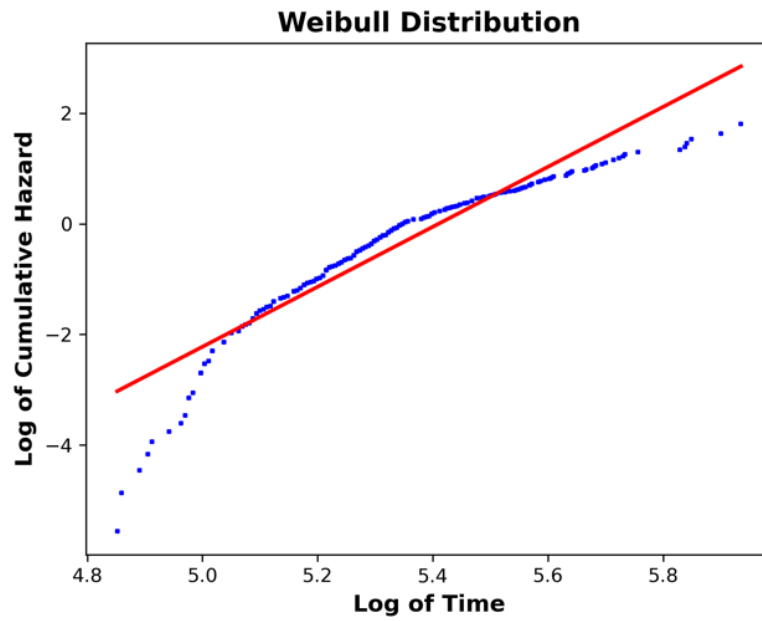

Figure 10. Visualization and selection of commonly used failure distributions (b) Weibull distribution

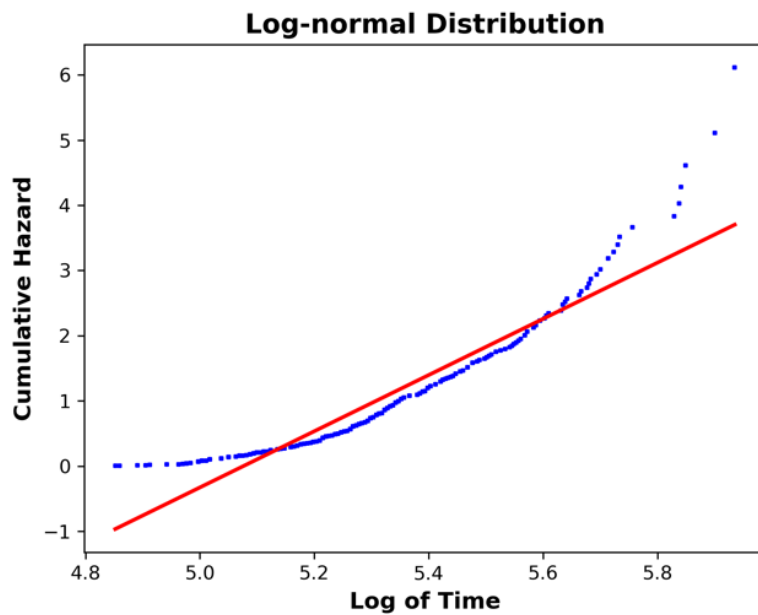

Figure 11. Visualization and selection of commonly used failure distributions (c) Lognormal distribution.

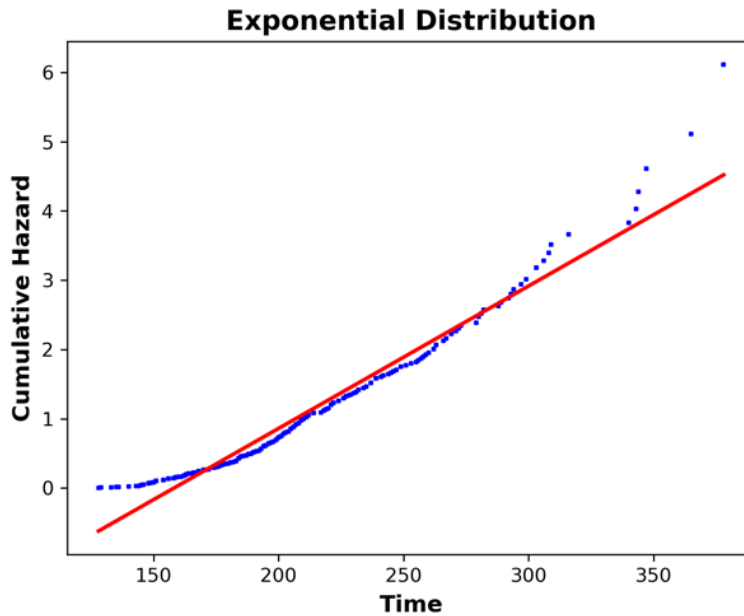

Figure 12. Visualization and selection of commonly used failure distributions (d) Exponential distribution

Once the Log-logistic distribution is selected, the next step is to determine its parameters. These parameters are calculated by linearizing the cumulative hazard plot, which allows for the application of a linear regression approach. The shape parameter of the selected Log-logistic distribution is found to be 8.1152, while the scale parameter is 201.3504. These parameters correspond to the slope coefficient and intercept of the linear function, respectively. By capturing the appropriate slope and scale of the failure data, the Log-logistic distribution provides a robust baseline for the Cox model.

In summary, the selection of the Log-logistic distribution as the baseline hazard function ensures that the model is well-calibrated to the underlying failure data from the FD002 subset. This choice is supported by the high R^2 score and the precise determination of the shape and scale parameters,

which collectively contribute to a more accurate and reliable hazard function for the improved Cox model.

5.2.2.2 Selection of the Covariates

As discussed in Section 4.2, the selection of covariates is a critical step in building the Cox model. In this study, the calculated dataset representing the differences between healthy and failure conditions for all available gas path parameters in the FD002 training set is used for covariate selection. These gas path parameters reflect various operational states of the gas turbine and provide insight into how specific variables contribute to the hazard rate of failure.

The covariate selection process involves individually adding each gas path parameter to the Cox model to evaluate its significance in predicting turbine failure. This evaluation is performed using the Wald statistical test, which assesses the impact of each covariate on the hazard rate. Covariates that meet the statistical significance threshold ($P\text{-value} < 0.05$) are selected for inclusion in the model, ensuring that only relevant and meaningful parameters are incorporated into the final hazard function.

While both the proposed Cox model and the traditional Cox model follow the same covariate selection process, their results differ due to the nature of the datasets used. The traditional Cox model directly uses sensor measurements as covariates, whereas the proposed model relies on the calculated dataset of differences between healthy and failure conditions. This differentiation allows the proposed method to more effectively isolate the impact of degradation while minimizing interference from normal operational fluctuations.

Table 4 presents a comparative analysis of the covariates selected by the improved Cox model and the traditional Cox method, both of which are based on the FD002 dataset. The proposed method ranks the covariates N_c (core speed) and NR_c (corrected core speed) as the most significant, placing them first and second, respectively. These parameters are closely associated with the core's rotational speed and reflect key aspects of turbine performance that can indicate early signs of failure.

In contrast, the traditional Cox method selects NR_c and NR_f (corrected fan speed) for the same ranks, highlighting the differences in covariate selection between the two approaches. While NR_c is identified as significant in both models, the traditional method places greater emphasis on fan speed-related measurements, whereas the proposed method focuses more on core-related parameters.

Table 4. Covariates selection based on FD002 subset

Rank	Covariates selection		AIC		Chi-Square (Wald)		P-Value (Wald)	
	Proposed method	Cox traditional	Proposed method	Cox traditional	Proposed method	Cox traditional	Proposed method	Cox traditional
1	N_c	NR_c	2361.571	2367.574	21.6572	20.1375	<.0001	<.0001
2	NR_c	NR_f	2366.356	2378.797	17.2484	7.2425	<.0001	0.0071

For both ranks, the proposed method using the calculated dataset demonstrates better performance for the selected covariates compared to the traditional Cox model. This performance is evaluated through several key metrics, including the Akaike Information Criterion (AIC), Chi-Square (Wald) test and P - Value, all of which provide insights into the model's fit and the statistical significance of the selected covariates.

In the first rank, the proposed method achieves a lower AIC value of 2361.571, compared to 2367.574 for the traditional Cox method. A lower AIC value indicates that the proposed model offers a better balance between goodness of fit and model complexity, suggesting that the selected covariates improve the model's ability to predict failure rates. The Chi-Square (Wald) value for the proposed method is 21.6572, which is higher than the 20.1375 obtained by the traditional Cox method. This higher value reflects a stronger contribution of the covariate N_c (core speed) to the model's prediction of the hazard rate. Both methods return highly significant p-values of <0.0001 , further reinforcing the statistical significance of the selected covariates in this rank.

In the second rank, the proposed method also outperforms the traditional Cox model by achieving an AIC value of 2366.356, which is lower than the 2378.797 reported by the traditional method. The Chi-Square (Wald) value for the proposed method is 17.2484, significantly higher than the 7.2425 obtained by the traditional Cox method. This suggests that the covariate NR_c (corrected core speed) plays a much more substantial role in hazard prediction when using the proposed method. The P-values for the proposed and traditional methods are <0.0001 and 0.0071, respectively, indicating a much stronger statistical significance for the proposed method in the second rank.

These comparative results indicate that by using the calculated dataset, the proposed Cox model is able to select covariates that contribute more effectively to the model's predictive power. The use of differences between healthy and failure conditions as covariates allows the proposed model to capture the effects of degradation with greater accuracy, while the traditional method, relying on raw sensor data, may not fully account for these nuances. This is reflected in the consistently lower

AIC values and higher Chi-Square (Wald) values observed for the proposed method across both ranks.

The magnitude of the coefficients of the selected covariates further illustrates the effectiveness of the improved Cox model. In the context of the Cox model, the absolute value of a coefficient represents the strength of the covariate's impact on failure time. A larger absolute value indicates that the covariate has a more substantial effect on the risk of failure, meaning changes in this covariate will significantly alter the likelihood of failure occurring.

For the improved Cox model, the coefficient for N_c (core speed) is -5.40102, and for NR_c (corrected core speed), it is 3.44370. These values indicate that a decrease in N_c strongly decreases the risk of failure, while an increase NR_c significantly increases the risk of failure. The magnitudes of these coefficients reflect the important roles that core speed and corrected core speed play in predicting gas turbine failures under varying working conditions.

In comparison, the coefficients in the traditional Cox model are -2.36273 for NR_c and 0.83335 for NR_f (corrected fan speed). The lower absolute values of these coefficients suggest that, in the traditional model, the selected covariates exert a weaker influence on the failure prediction compared to the covariates selected by the improved method. This difference in coefficient magnitude highlights the improved model's ability to identify covariates that have a stronger and more meaningful association with the hazard rate.

The improved Cox model consistently demonstrates better performance in selecting covariates, as evidenced by its lower AIC values, higher Chi-Square (Wald) values, and significant p-values. These results reflect the model's enhanced capacity to fit the data more accurately and to select

covariates that exhibit higher statistical significance. The stronger relationships between the selected covariates and the risk of failure, as indicated by the larger coefficient magnitudes, emphasize the improved model's effectiveness in identifying key factors that drive gas turbine reliability.

5.2.2.3 Validation of the Proposed Reliability Analysis Method

This section focuses on validating the performance of the proposed reliability analysis method by comparing its results with those of the traditional Cox model. The comparison is made by analyzing the reliability curves generated from each method. These curves visually represent the reliability of a gas turbine over time, based on the respective model's predictions. By comparing the curves, we can directly observe how each method performs in predicting gas turbine failures.

Figure 13 presents an example of two reliability curves for Turbine No. 250, operating at cycle 50. The curves illustrate the predicted reliability of the turbine as it progresses toward failure, offering a direct comparison between the proposed method (using the differences) and the traditional Cox model (using raw sensor measurements).

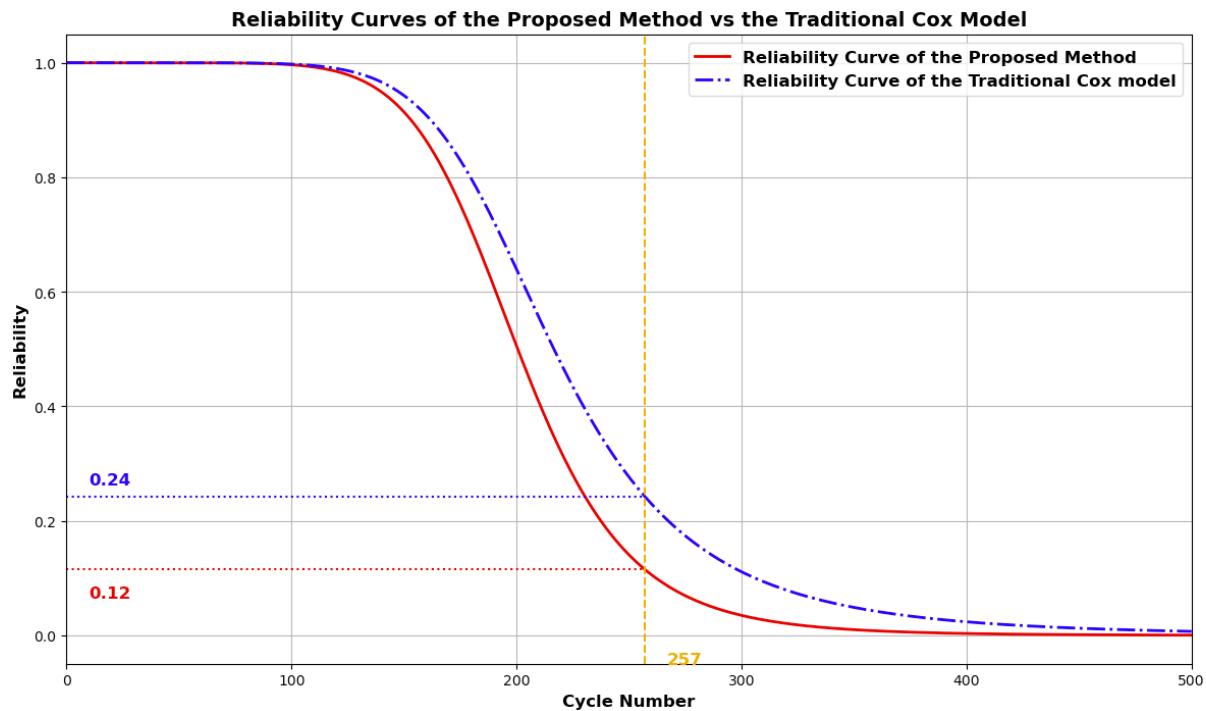

Figure 13. Turbine 250 reliability curves updated using its operational data at cycle 50

In Figure 13, the red curve represents the proposed method, while the blue curve represents the traditional Cox model. The vertical dashed orange line intersects the x-axis at cycle 257, which corresponds to the actual failure cycle of the gas turbine. This line serves as a reference point for evaluating the accuracy of each method, as the goal of a reliability model is to predict the failure time as closely as possible.

The intersections of the dashed line with the two reliability curves indicate the predicted reliability values at the turbine's failure time. Since the theoretical reliability value at failure is 0, the predicted reliability values can be compared to assess the accuracy of each approach. A smaller predicted reliability value at the failure time indicates that the corresponding reliability analysis method provides a more accurate prediction of the turbine's failure.

At cycle 50, the predicted reliability value at the failure time based on the proposed method is 0.12, which is lower than the 0.24 predicted by the traditional Cox model. This lower reliability value suggests that the proposed method more accurately anticipates the turbine's failure at cycle 257, compared to the traditional Cox model. In other words, the proposed method's reliability curve more closely aligns with the actual failure event, providing a stronger prediction of when the failure will occur.

This comparison highlights the superiority of the proposed method at cycle 50, as it delivers a more precise estimate of the gas turbine's reliability as it approaches failure. The ability to predict a lower reliability value at the failure time demonstrates that the proposed method better captures the turbine's degradation patterns, leading to more reliable failure predictions. As a result, the proposed method outperforms the traditional Cox model for this specific turbine.

To further evaluate the general performance of the proposed method, Table 5 summarizes the performance metrics for five gas turbines (out of 259) using both the proposed method and the traditional Cox model. These performance metrics provide a broader comparison across multiple turbines, enabling us to assess the robustness and consistency of the proposed reliability analysis approach.

Table 5. Performance metrics of the proposed reliability analysis method for five gas turbines in the FD002 subset

Subset	Turbine No.	Cycles (censor time)	RUL	Failure cycle	The proposed method	
					Number of better outcomes	Percentage of better outcomes
FD002	44	164	6	170	160	97.56%

63	174	39	213	171	98.28%
175	83	142	225	81	97.59%
189	178	43	221	174	97.75%
244	49	181	230	48	97.96%

For instance, in the case of gas turbine No. 44, the turbine was censored at cycle 164, meaning the data was cut off at this point, and the RUL was determined to be 6 cycles. This RUL indicates that the true failure cycle for the turbine is cycle 170. To evaluate the performance of the proposed method, a comparison was conducted for each of the 164 cycles between the two approaches. The results reveal that the proposed method achieves 160 better outcomes out of the 164 cycles, representing an impressive 97.56% accuracy. In contrast, the traditional Cox model only achieved 4 better outcomes (2.44%), and these outcomes were randomly distributed, indicating weaker performance.

Similarly, for gas turbine No. 63, a similar performance comparison was conducted. The proposed method demonstrated 171 better outcomes, achieving an accuracy of 98.28%. The traditional Cox model, on the other hand, only provided 3 better outcomes, representing a low accuracy rate of 1.72%. These results once again reinforce the superior performance of the proposed method in accurately predicting the reliability and failure time of the turbine compared to the traditional model.

These case-specific comparisons highlight the effectiveness of the proposed method in gas turbine reliability analysis. Across all five gas turbines evaluated, the proposed method consistently demonstrated a higher percentage of better outcomes compared to the traditional Cox model. This

consistency suggests that the proposed method is more adept at capturing the degradation patterns of gas turbines, leading to more reliable predictions of failure times.

To further evaluate the generalizability of the proposed method, additional validations were performed across all 259 gas turbines in the FD002 test set. The performance comparison was extended to all cycles of these turbines, allowing for a comprehensive assessment of the method's predictive capabilities. The results showed that the percentage of better outcomes using the proposed method remained consistently higher across all turbines at their respective failure times. This indicates that the proposed method outperforms the traditional Cox model across the entire dataset, demonstrating its robustness in predicting gas turbine reliability under multiple flight conditions.

These findings confirm the effectiveness of the proposed method in reliability analysis, especially under varying environmental and operational conditions. By using the differences between healthy and failure conditions as covariates, the proposed method captures the turbine's degradation more accurately, allowing for more reliable failure predictions. This improved performance over the traditional Cox model highlights the proposed method's value as a more accurate and comprehensive tool for gas turbine reliability analysis.

Table 6 presents a performance comparison between the proposed reliability analysis method and the traditional Cox model, focusing on the five turbines randomly selected from the FD001 subset, as discussed in Section 5.1. These turbines were chosen to evaluate the generalizability of the proposed method beyond the FD002 subset, ensuring its effectiveness under different flight conditions and operational settings.

The table shows that the reliability values at failure time using the proposed method are consistently smaller than those obtained with the traditional Cox model across all cycles. This consistent trend indicates that the proposed method outperforms the traditional approach in all cases, providing a more accurate prediction of the failure time for each turbine.

In particular, the proposed method's ability to generate smaller reliability values at failure time demonstrates its improved accuracy in anticipating gas turbine failure. A smaller reliability value indicates a closer alignment with the actual failure event, making the proposed method more reliable for practical applications in gas turbine maintenance and reliability assessment.

These results also demonstrate that the proposed reliability analysis method is equally effective for the FD001 subset, despite the different flight conditions and operational settings compared to the FD002 subset. The ability of the proposed method to consistently outperform the traditional Cox model in both subsets highlights its robustness and generalizability across varying datasets.

The performance of the proposed method across these five turbines highlights its potential to provide more precise failure predictions, leading to better maintenance planning and operational decision-making. By applying this method, operators can more effectively predict when a gas turbine is likely to fail, allowing for proactive maintenance actions that could reduce downtime and improve overall system reliability.

Table 6. Performance metrics of the proposed method for 5 selected gas turbines in the FD001 subset

Subset	Turbine No.	Cycles	RUL	Failure cycle	The proposed method	
					Number of better outcomes	Percentage of better outcomes

	92	150	20	170	150	100%
	49	303	21	324	303	100%
FD001	26	76	119	195	76	100%
	72	131	50	181	131	100%
	81	213	8	221	213	100%

The validations conducted on the C-MAPSS dataset clearly demonstrate the robustness of the proposed reliability analysis method in handling gas turbine performance under various working conditions. By comparing the proposed method to the traditional Cox model across different datasets (FD001 and FD002), it is evident that the proposed method consistently delivers better outcomes in predicting turbine reliability and failure times.

The superior performance of the proposed method is particularly notable in its ability to capture the degradation patterns more accurately, resulting in lower predicted reliability values at failure time. This improvement in predictive accuracy translates into better maintenance planning and more reliable operational decision-making, as it allows operators to address potential failures before they occur.

Moreover, the proposed method demonstrates an enhanced ability to manage the complexities of multiple flight conditions, as evidenced by its consistent outperformance of the traditional Cox model across all 259 gas turbines in the FD002 test set. These findings highlight the proposed method's ability to generalize across different working scenarios, providing a more accurate and flexible tool for gas turbine reliability analysis.

In summary, the proposed reliability analysis method significantly enhances the overall accuracy of failure predictions, offering a robust and reliable approach for gas turbine performance monitoring compared to the traditional Cox model.

6 Conclusion

This paper presents a novel reliability analysis method for aviation gas turbines, enhancing the traditional Cox model by incorporating new covariates developed through machine learning. By addressing the limitations of previous studies that used the Cox model for gas turbine reliability analysis, the proposed method offers a more accurate and resilient approach. Specifically, the proposed method better reflects turbine degradation patterns and is less affected by the variability introduced by different operational and environmental conditions. This improvement allows for a more precise evaluation of gas turbine reliability, ensuring that failure predictions are more accurate and actionable.

The proposed method provides two significant contributions to the field of gas turbine reliability analysis. First, a machine learning model is developed to represent a healthy gas turbine, given inputs related to environmental and operational conditions. By simulating the expected behaviour of a healthy turbine, this model serves as a baseline for generating new covariates. These covariates are derived by calculating the differences between the healthy simulations and real-time sensor measurements from gas turbines, which reflect their actual operational state. This approach allows the model to capture early indicators of degradation that traditional sensor-based methods may overlook.

Second, an improved Cox model is constructed, designed to better analyze the reliability of gas turbines by utilizing a selected baseline hazard function from four commonly used failure distributions. This selection is based on run-to-failure data, ensuring that the chosen distribution aligns with the actual failure characteristics of the turbine. Additionally, the model incorporates a

calculated dataset, derived from the differences between healthy and failure conditions, to select covariates and estimate the corresponding coefficients. This process allows the improved Cox model to accommodate new covariates and dynamically adjust to changing operational settings, providing more accurate predictions of failure times.

The proposed method was validated on a dataset of 264 gas turbines, and the results demonstrate its superior accuracy in predicting turbine failures when compared to the traditional Cox model. By consistently outperforming the traditional approach across multiple validation scenarios, the proposed method shows strong potential for use in real-world applications. The findings indicate that this method can accurately assess gas turbine reliability, even under varying environmental conditions and operational settings. This advancement represents a significant step forward in condition-based monitoring and reliability analysis of gas turbines, with the added benefit of reduced sensitivity to environmental and operational variability.

Looking ahead, future research will focus on expanding the method's applicability to include multiple failure modes. By developing and validating a model capable of analyzing a wider range of failure scenarios, the reliability assessment of gas turbines can be further improved. This continued development will enable more comprehensive monitoring and predictive maintenance strategies, ultimately leading to enhanced operational efficiency and reduced downtime for aviation gas turbines. Additionally, future work could explore the integration of sequential modeling techniques, such as Long Short-Term Memory (LSTM) networks, to better capture degradation trends across flight cycles. While the current approach derives covariates based on deviations from a healthy baseline, LSTM-based models could enhance the method's ability to learn temporal dependencies in sensor data, particularly when failure progression exhibits gradual,

long-term trends. Given that the NASA C-MAPSS dataset does not include an explicit time variable, flight cycles could serve as a sequential index, allowing the model to capture evolving failure characteristics over time. This extension could lead to a more dynamic and adaptive reliability assessment framework, further improving the accuracy of failure time predictions, especially under varying operational conditions.

Reference

- [1] R. Kurz and K. Brun, “Gas turbine performance,” presented at the Asia Turbomachinery & Pump Symposium. 2016 Proceedings., Turbomachinery Laboratories, Texas A&M Engineering Experiment Station, 2016.
- [2] C. Keller, “Forty years of experience on closed-cycle gas turbines,” *Ann. Nucl. Energy*, vol. 5, no. 8–10, pp. 405–422, 1978.
- [3] S. Ahsan, T. A. Lemma, M. B. Hashmi, and X. Liang, “Investigation of operational settings, environmental conditions, and faults on the gas turbine performance,” *Meas. Sci. Technol.*, vol. 35, no. 12, p. 125902, 2024.
- [4] D. J. Enyia, “Comparative Study of a Simulated and Real Life Reliability of Turbine Gas Path Diagnostics,” *Int. J. Innov. Res. Eng. Manag.*, vol. 10, no. 4, pp. 99–105, 2023.
- [5] M. Yang, W. Wang, Y. Zhang, J. Cai, and W. Liu, “Research on Reliability Design Analysis Application to Gas Turbines,” in *Progressive Decision-Making Tools and Applications in Project and Operation Management: Approaches, Case Studies, Multi-criteria Decision-Making, Multi-objective Decision-Making, Decision under Uncertainty*, Springer, 2024, pp. 173–189.
- [6] H. Rinne, *The Weibull distribution: a handbook*. Chapman and Hall/CRC, 2008.
- [7] M. M. Ibrahim, M. Badr, and A. El Berry, “Reliability Analysis of Gas Turbine Power Plant Based on Failure Data”.

- [8] A. Z. Djeddi, A. Hafaifa, A. Iratni, and A. Kouzou, "Gas turbine reliability estimation to reduce the risk of failure occurrence with a comparative study between the two-parameter Weibull distribution and a new modified Weibull distribution," *Diagnostyka*, vol. 23, 2022.
- [9] N. Goyal, M. Ram, S. Amoli, and S. Jagga, "Effect of Equipment's Failure on Gas Turbine Power Plant," in *Advanced Applications in Manufacturing Engineering*, Elsevier, 2019, pp. 79–103.
- [10] W. E. Forsthoffer, *Forsthoffer's Proven Guidelines for Rotating Machinery Excellence*. Butterworth-Heinemann, 2021.
- [11] C. Chen, Y. Liu, X. Sun, C. D. Cairano-Gilfedder, and S. Titmus, "An integrated deep learning-based approach for automobile maintenance prediction with GIS data," *Reliab. Eng. Syst. Saf.*, vol. 216, p. 107919, Dec. 2021, doi: 10.1016/j.res.2021.107919.
- [12] C. Chen *et al.*, "Predictive maintenance using cox proportional hazard deep learning," *Adv. Eng. Inform.*, vol. 44, p. 101054, Apr. 2020, doi: 10.1016/j.aei.2020.101054.
- [13] Y. Wen, X. Guo, J. Son, and J. Wu, "A neural-network-based proportional hazard model for IoT signal fusion and failure prediction," *IISE Trans.*, vol. 55, no. 4, pp. 377–391, Apr. 2023, doi: 10.1080/24725854.2022.2030881.
- [14] F. Wang, X. Chen, C. Liu, D. Yan, Q. Han, and H. Li, "Reliability assessment of rolling bearing based on principal component analysis and Weibull proportional hazard model," in *2017 IEEE International Instrumentation and Measurement Technology Conference (I2MTC)*, Torino, Italy: IEEE, May 2017, pp. 1–6. doi: 10.1109/I2MTC.2017.7969987.

- [15] A. Z. Djeddi, A. Hafaifa, M. Guemana, and A. Kouzou, "Gas turbine reliability modelling based on a bath shaped rate failure function: modified Weibull distribution validation," *Life Cycle Reliab. Saf. Eng.*, vol. 9, pp. 437–448, 2020.
- [16] A. Z. Djeddi, A. Hafaifa, and A. Salam, "Operational reliability analysis applied to a gas turbine based on three parameter Weibull distribution," *Mechanics*, vol. 21, no. 3, pp. 187–192, 2015.
- [17] W. Weibull, "A statistical distribution function of wide applicability," *J. Appl. Mech.*, 1951.
- [18] M. E. Melis, E. V. Zaretsky, and R. August, "Probabilistic analysis of aircraft gas turbine disk life and reliability," *J. Propuls. Power*, vol. 15, no. 5, pp. 658–666, 1999.
- [19] S. Ahsan, T. A. Lemma, and M. A. Gebremariam, "Reliability analysis of gas turbine engine by means of bathtub-shaped failure rate distribution," *Process Saf. Prog.*, vol. 39, no. S1, p. e12115, Mar. 2020, doi: 10.1002/prs.12115.
- [20] F. Carazas and G. De Souza, "Availability analysis of gas turbines used in power plants," *Int. J. Thermodyn.*, vol. 12, no. 1, pp. 28–37, 2009.
- [21] W. Nelson, "Theory and applications of hazard plotting for censored failure data," *Technometrics*, vol. 14, no. 4, pp. 945–966, 1972.
- [22] E. L. Kaplan and P. Meier, "Nonparametric estimation from incomplete observations," *J. Am. Stat. Assoc.*, vol. 53, no. 282, pp. 457–481, 1958.
- [23] M. K. Goel, P. Khanna, and J. Kishore, "Understanding survival analysis: Kaplan-Meier estimate," *Int. J. Ayurveda Res.*, vol. 1, no. 4, p. 274, 2010.

- [24] M. P. Enright and R. C. McClung, “A probabilistic framework for gas turbine engine materials with multiple types of anomalies,” 2011.
- [25] A. Ragab, M.-S. Ouali, S. Yacout, and H. Osman, “Remaining useful life prediction using prognostic methodology based on logical analysis of data and Kaplan–Meier estimation,” *J. Intell. Manuf.*, vol. 27, pp. 943–958, 2016.
- [26] D. R. Cox, “Regression Models and Life-Tables,” *J. R. Stat. Soc. Ser. B Methodol.*, vol. 34, no. 2, pp. 187–202, Jan. 1972, doi: 10.1111/j.2517-6161.1972.tb00899.x.
- [27] S. Vittal, P. Hajela, and A. Joshi, “Review of approaches to gas turbine life management,” presented at the 10th AIAA/ISSMO Multidisciplinary Analysis and Optimization Conference, 2004, p. 4372.
- [28] A. K. S. Jardine, P. M. Anderson, and D. S. Mann, “Application of the weibull proportional hazards model to aircraft and marine engine failure data,” *Qual. Reliab. Eng. Int.*, vol. 3, no. 2, pp. 77–82, Apr. 1987, doi: 10.1002/qre.4680030204.
- [29] C. E. Love and R. Guo, “Application of weibull proportional hazards modelling to bad-as-old failure data,” *Qual. Reliab. Eng. Int.*, vol. 7, no. 3, pp. 149–157, May 1991, doi: 10.1002/qre.4680070306.
- [30] T. H. Rashidi and A. (Kouros) Mohammadian, “Parametric Hazard Functions: Overview,” *Transp. Res. Rec. J. Transp. Res. Board*, vol. 2230, no. 1, pp. 48–57, Jan. 2011, doi: 10.3141/2230-06.
- [31] M. J. Crowther and P. C. Lambert, “**stgenreg**: A *Stata* Package for General Parametric Survival Analysis,” *J. Stat. Softw.*, vol. 53, no. 12, 2013, doi: 10.18637/jss.v053.i12.

- [32] Q. Zhang, C. Hua, and G. Xu, "A mixture Weibull proportional hazard model for mechanical system failure prediction utilising lifetime and monitoring data," *Mech. Syst. Signal Process.*, vol. 43, no. 1–2, pp. 103–112, Feb. 2014, doi: 10.1016/j.ymssp.2013.10.013.
- [33] A. Diamoutene, F. Nouredine, B. Kamsu-Foguem, and D. Barro, "Reliability Analysis with Proportional Hazard Model in Aeronautics," *Int. J. Aeronaut. Space Sci.*, vol. 22, no. 5, pp. 1222–1234, Oct. 2021, doi: 10.1007/s42405-021-00371-1.
- [34] Z. Zhicai, L. Dongfeng, and S. Xinfu, "Research on combination of data-driven and probability-based prognostics techniques for equipments," in *2014 Prognostics and System Health Management Conference (PHM-2014 Hunan)*, Zhangjiajie City, China: IEEE, Aug. 2014, pp. 323–326. doi: 10.1109/PHM.2014.6988187.
- [35] W. Hu, Z. Yang, C. Chen, Y. Wu, Q. Xie, and X. Zhu, "Reliability Assessment of Machine Tools Considering Multi-effects of Working Conditions," *IOP Conf. Ser. Mater. Sci. Eng.*, vol. 1043, no. 3, p. 032036, Jan. 2021, doi: 10.1088/1757-899X/1043/3/032036.
- [36] R. Zheng, S. Najafi, and Y. Zhang, "A recursive method for the health assessment of systems using the proportional hazards model," *Reliab. Eng. Syst. Saf.*, vol. 221, p. 108379, 2022.
- [37] Z. Shi and A. Chehade, "A dual-LSTM framework combining change point detection and remaining useful life prediction," *Reliab. Eng. Syst. Saf.*, vol. 205, p. 107257, 2021.
- [38] X. Li, Q. Ding, and J.-Q. Sun, "Remaining useful life estimation in prognostics using deep convolution neural networks," *Reliab. Eng. Syst. Saf.*, vol. 172, pp. 1–11, 2018.

- [39] R. Xiao, T. Zayed, M. A. Meguid, and L. Sushama, “Improving failure modeling for gas transmission pipelines: A survival analysis and machine learning integrated approach,” *Reliab. Eng. Syst. Saf.*, vol. 241, p. 109672, 2024.
- [40] A. Saxena, D. Simon, and N. Eklund, “Damage Propagation Modeling for Aircraft Engine Run-to-Failure Simulation”.