

**ROLES OF IRON UPTAKE IN THE SURVIVAL,
COLONIZATION AND VIRULENCE OF *SALMONELLA* IN
ANIMAL GUTS**

BY

ZHIGANG TAN

A thesis submitted to The Faculty of Graduate Studies of

The University of Manitoba

In partial fulfillment of the requirements of the degree of

MASTER OF SCIENCE

Department of Animal Science

University of Manitoba

Winnipeg, Manitoba, Canada

© Zhigang Tan, 2019

ABSTRACT

Non-Typhi *Salmonella* (NTS) is one of the zoonotic pathogens that can cause contamination in feed ingredients and animal products, and then pose a critical threat to human and animal health. The mechanisms used by *Salmonella* to successfully infect poultry still need to be determined to successfully develop mitigation strategies. The gut is the location where the *Salmonella* infection is initiated; therefore to reduce the risk of salmonellosis, preventing the colonization and invasion of *Salmonella* in the gut is essential. This study aims to evaluate the roles of iron uptake in the survival, colonization and virulence of *Salmonella* in animal guts using Caco-2 cells and *Caenorhabditis elegans* (*C. elegans*) models. Our results suggest that iron chelators inhibited the growth of wild-type and iron-uptake defective mutants of *Salmonella*. Iron uptake systems were required for the survival, colonization and virulence of *Salmonella* in *C. elegans*. These findings could help to develop natural compounds and biocontrol agents (e.g. specific iron sources and iron chelators) based on iron uptake system proteins for controlling *Salmonella* to mitigate potential threats to public health, enhance consumer confidence in Canadian Agri-food products and reduce the cost associated with foodborne illness.

ACKNOWLEDGEMENTS

First and most of all, I sincerely appreciate my advisors, Dr. Chengbo Yang and Dr. Joshua Gong, for offering me the golden opportunity to carry out this project. I am grateful for their tremendous patience, guidance and financial support in the past two years. I greatly appreciate the valuable suggestions from Dr. Moussa Diarra through the entirety of the program. Furthermore, the suggestions and guidance from my advisory committee members Dr. Karmin O and Dr. Claudia Narváez-Bravo are much appreciated. I am also grateful for the continuous support from Dr. Hai Yu, the lab technician in Agriculture-Agri-Food Canada (AAFC-Guelph); for offering me training, troubleshooting, data analysis and manuscript revision. In addition, the supervision and advice from Dr. Xianhua Yin and Dr. Samuel Mohammed Chekabab were vital to me in the completion of this program. I kindly appreciate the help from the research associates and visiting scholars in Dr. Yang's lab, including Dr. Bin Shan, Ms. Liju Ni, Dr. Shangxi Liu, and Dr. Li Yu, for guiding me through many aspects of the program. Special thanks also go to Dr. Hua Zhang for her mentorship from the tissue culture experiment. I am thankful for my peers, summer student Emily Ammeter and graduate students at AAFC-Guelph and the Livestock Nutrition and Nutritional Biochemistry lab as well as other students at the Department of Animal Science. It was an enjoyable experience for me to work and study with them. At last, I reserve my greatest thanks to my parents for their endless, unconditional and unmeasurable love.

FOREWORD

Part of this thesis has been presented as an oral presentation at the ASAS-CSAS Annual Meeting & Trade Show in Vancouver, Canada on July 6-12, 2018. This thesis is written in manuscript style and is composed of one manuscript. The manuscript has been submitted to ACS Omega.

The manuscripts include:

Manuscript: Zhigang Tan, Samuel Chekabab, Hai Yu, Xinhua Yin, Moussa S. Diarra, Chengbo Yang, and Joshua Gong. 2019. Growth and virulence of *Salmonella* Typhimurium deficient in iron-uptake. Submitted. ACS Omega.

TABLE OF CONTENTS

ABSTRACT.....	I
ACKNOWLEDGEMENTS.....	II
FOREWORD	III
LIST OF TABLES	VIII
LIST OF FIGURES	IX
LIST OF ABBREVIATIONS.....	XI
CHAPTER 1 GENERAL INTRODUCTION.....	15
CHAPTER 2 LITTERATURE REVIEW	18
2.1 BIOLOGICAL ROLES OF IRON IN <i>SALMONELLA</i>	18
2.2 IRON HEMOSTASIS IN <i>SALMONELLA</i>	19
2.3 IRON STORAGE AND UPTAKE IN <i>SALMONELLA</i>	19
2.4 COMPETITION FOR IRON BETWEEN <i>SALMONELLA</i> AND THE HOST.....	21
2.5 EFFECT OF IRON ON THE INFECTION OF <i>SALMONELLA</i>	29
2.5.1 Models to study <i>Salmonella</i> infection.....	29
2.5.2 Infection mode of <i>Salmonella</i>	31
2.5.3 Iron concentrations and the growth and infection of <i>Salmonella</i>	34
2.5.4 Iron forms and the growth and infection of <i>Salmonella</i>	36
2.5.5 Iron amino acid chelates and the growth and infection of <i>Salmonella</i>	36
2.6 REGULATION OF IRON ABSORPTION AND METABOLISM IN POULTRY	38
2.6.1 Iron deficiencies.....	38
2.6.2 Dietary iron forms.....	38

2.6.3 Systematic iron balance	39
2.6.4 Intestinal iron absorption	41
2.6.5 Regulation of intestinal iron absorption.....	44
2.6.6 Regulation of iron metabolism.....	45
2.7 APPLICATION OF IRON METABOLISM IN THE CONTROL OF <i>SALMONELLA</i> IN POULTRY	46
CHAPTER 3 HYPOTHESES AND OBJECTIVES.....	56
3.1 HYPOTHESES	56
3.2 OBJECTIVES	56
CHAPTER 4 MANUSCRIPT.....	57
GROWTH AND VIRULENCE OF <i>SALMONELLA</i> TYPHIMURIUM DEFICIENT IN IRON-UPTAKE	57
4.1 ABSTRACT	57
4.2 INTRODUCTION.....	57
4.3 MATERIALS AND METHODS.....	60
4.3.1 Materials	60
4.3.2 Iron content analysis using inductively coupled plasma optical emission spectrometry (ICP-OES).....	60
4.3.3 Bacterial strains and growth conditions.....	61
4.3.4 Evaluation of bacterial growth on different forms of iron.....	61
4.3.5 Evaluation of iron chelators for inhibiting bacterial growth.....	62
4.3.6 Cell line and growth conditions	62

4.3.7 Caco-2 invasion assay.....	63
4.3.8 Assay for Caco-2 tight junction permeability	63
4.3.9 <i>C. elegans</i> life-span assay.....	64
4.3.10 Total RNA extraction and cDNA synthesis.....	65
4.3.11 Quantitative PCR analysis	66
4.3.12 Statistical analysis.....	68
4.4 RESULTS	74
4.4.1 Effect of different iron forms on <i>Salmonella</i> growth.....	74
4.4.2 Deletion of TonB, IroN and FepA on <i>Salmonella</i> growth	76
4.4.2 Effect of iron chelators on the growth of <i>Salmonella</i>	79
4.4.3 Deletion of TonB, IroN and FepA on the invasion of Caco-2 cells	83
4.4.4 Deletion of TonB, IroN and FepA on the tight junction permeability of Caco-2 cells	84
4.4.5 Host response of Caco-2 cells to <i>Salmonella</i> WT and its TonB, IroN and FepA mutants.....	87
4.4.6 Deletion of TonB, IroN and FepA on the life-span of <i>C. elegans</i>	91
4.4.7 Host response of <i>C. elegans</i> to <i>Salmonella</i> WT and its TonB, IroN and FepA mutants.....	93
4.5 DISCUSSION	96
4.6 CONCLUSION	100
CHAPTER 5 GENERAL DISCUSSION AND CONCLUSION.....	101
5.1 GENERAL DISCUSSION	101
5.2 GENERAL CONCLUSION.....	105

CHAPTER 6 FUTURE DIRECTIONS 107

CHAPTER 7 LITERATURE CITED 108

LIST OF TABLES

Table 2.1 Fundamental regulatory proteins relating to iron in <i>Salmonella enterica</i>	51
Table 2.2 Endogenous siderophores of <i>Salmonella enterica</i>	52
Table 2.3 Exogenous siderophores of <i>Salmonella enterica</i>	53
Table 2.4 Iron requirement in different breeds of poultry (broiler, layer, quail)	54
Table 4.1 Bacterial strains used in the thesis	69
Table 4.2 Primers of qPCR assay for Caco-2 cells.....	70
Table 4.3 Primers of qPCR assay for <i>C. elegans</i>	72

LIST OF FIGURES

Figure 2.1 Postulated iron-uptake mechanism of <i>Salmonella</i> species.	25
Figure 2.2 Iron uptake, circulation, and recycling in poultry.....	41
Figure 2.3 The postulated mechanism of iron absorption in poultry.	43
Figure 4.1 Effects of different iron forms on the growth of <i>Salmonella</i> Typhimurium....	75
Figure 4.2 Effects of different concentrations of ferric chloride on the growth of <i>Salmonella</i> Typhimurium.....	77
Figure 4.3 Comparison in the growth of the wild-type, mutant, and complementary strains of <i>Salmonella</i> Typhimurium on ferric chloride and ferric EDTA.	78
Figure 4.4 Effects of EDTA on the growth of wild-type <i>Salmonella</i> Typhimurium.....	80
Figure 4.5 Effects of citric acid on the growth of wild-type <i>Salmonella</i> Typhimurium.....	81
Figure 4.6 Effects of 2,2-bipyridyl on the growth of wild-type <i>Salmonella</i> Typhimurium.....	82
Figure 4.7 Effects of iron and iron-uptake mutation on <i>Salmonella</i> Typhimurium invasion into Caco-2 cells.....	84
Figure 4.8 Effects of iron and iron-uptake mutation on the ability of <i>Salmonella</i> to damage epithelial monolayer of Caco-2 cells.....	86
Figure 4.9 Gene expression of claudin 3 (CLDN3), tight junction protein 1 (TJP1), peptide transporter 1 (PepT1), tumor necrosis factor alpha (TNF- α), and interleukin 8 (IL- 8) in Caco-2 cells as the response to <i>Salmonella</i> invasion.	89

Figure 4.10 Effects of gene mutation in iron-uptake on the ability of *Salmonella* Typhimurium to infect *C. elegans*.....92

Figure 4.11 Host response of *C. elegans* at gene expression level to the infection of *Salmonella* Typhimurium wild-type and mutants.94

LIST OF ABBREVIATIONS

ABC	ATP-Binding Cassette
Act-1	Actin
<i>C. elegans</i>	<i>Caenorhabditis elegans</i>
CFU	Colony-Forming Unit
Caco-2	Human Colorectal Adenocarcinoma Cells
CLDN3	Claudin 3
Clec-85	C-type Lectin
Daf-16	Forkhead Box Proteins
DAF/IGF	Insulin-Like Signaling Pathway
DcytB	Duodenal Cytochrome B
DMT1	Divalent Metal Transporter1
EDTA	Ethylenediaminetetraacetic Acid
<i>E.coli</i> OP50	<i>Escherichia coli</i> OP50
Ent	Enterobactin
Fe	Iron
Fe-Ent	Ferric-Enterobactin
Fe-Gly	Iron Glycine Chelates

Fe²⁺	Ferrous Iron
Fe³⁺	Ferric Iron
FeSQ₄	Ferrous Sulfate
FeCl₃	Ferric Chloride
Fep system	Ferric-Enterobactin Transporter System
Fhu system	Ferrichrome-Iron Transporter System
FBS	Fetal Bovine Serum
Ftn-1	Ferritin 1(<i>Caenorhabditis elegans</i>)
Fgt-1	Facilitated Glucose Transporter Protein 1
FPN	Ferroportin
GAPDH	Glyceraldehyde 3-Phosphate Dehydrogenase
HCP1	Haem Carrier Protein 1
HO-1	Heme Oxygenase 1
IROMPs	Iron-Regulated Outer Membrane Proteins
<i>iroN</i>⁻<i>fepA</i>⁻	Mutant Strains Lack of <i>fepA</i> Gene and <i>iroN</i> Gene
IMDM	Iscoe's Modified Dulbecco's Medium
IL-2	Interleukin-2
IL-6	Interleukin-6

IL-8	Interleukin-8
LB	Lysogeny Broth
Lcn2	Lipocalin 2
Lys-7	Lysozyme-Like Protein 7
MOI	Multiplicity of Infection
NTS	Non-Typhi <i>Salmonella</i>
NGM	Nematode Growth Media
OD₆₀₀	Optical Density at 600 nm
p38 MAPK	P 38 Mitogen-Activated Protein Kinases Signaling Pathway
PBS	Phosphate Buffer Solution
PBP	Periplasmic Binding Protein
PCR	Polymerase Chain Reaction
PepT1	Peptide Transporter 1
Pmk-1	Mitogen-Activated Protein Kinase Pmk-1
qPCR	Quantitative Polymerase Chain Reaction
RT-PCR	Reverse Transcription Polymerase Chain Reaction
<i>S. enterica</i>	<i>Salmonella enterica</i>
SIFs	<i>Salmonella</i> -Induced Filaments

Spp-1	Secreted Phosphoprotein 1
Snb-1	Synaptobrevin-1
TEER	Transepithelial Electrical Resistance
T3SS	Type III Secretion System
TNF-α	Tumor Necrosis Factor Alpha
TJP1	Junction Protein 1
<i>tonB</i>⁻	Mutant Strains Lack of <i>tonB</i> Gene
WT	Wild-type

CHAPTER 1 GENERAL INTRODUCTION

A *Salmonella* strain from swinish intestines was first discovered and isolated by Theobald Smith in 1855. The strain name, *Salmonella*, comes from Dr. Daniel Elmer Salmon who is a colleague of Theobald Smith (Eng et al., 2015). The *Salmonella* species are rod-shaped facultative anaerobes belonging to the family of Enterobacteriaceae. By 2003, approximately 2,600 serotypes in the genus *Salmonella* have been isolated and identified using the Kauffman-White scheme (Allerberger et al., 2003). According to the nomenclatural system recommended by the World Health Organization (WHO), *Salmonella enterica* and *Salmonella bongori* are the only two species of genus *Salmonella* characterized by the difference of the 16S rRNA sequence (Reeves et al., 1989). Based on biochemical characteristics and genomic similarity, six subspecies are classified into *Salmonella enterica*. Generally, 99% of *Salmonella* diseases in mammals are caused by one of the subspecies, *S. enterica* subsp. *enterica* (I) (Brenner et al., 2000; Reeves et al., 1989).

Poultry and contaminated poultry products are the main sources of human salmonellosis. *Salmonella* species are able to induce gastrointestinal disease with high mortality in 1-3 day-old chicks and colonize the gastrointestinal tracts of older chickens without clinical signs (Barrow et al., 1987; Humphrey et al., 1989). *Salmonella* colonization in the gut poses a grave threat to food security and poultry health. For example, (1) *Salmonella* may contaminate meat through cross contamination; (2) some *Salmonella* strains such as *Salmonella* Heidelberg are capable of being transmitted from infected laying hens to eggs through internal vertical transmission before the formation of the eggshell; (3) fecal shedding and horizontal transmission is possible within the flock, especially for

broilers, due to the coprophagy and efficient fecal-oral infection route (Awad and Ghareeb, 2014; Gast et al., 2007; Smith et al., 2005). Fowl typhoid is caused by *Salmonella Gallinarum* which has a horizontal transmission route (Basnet et al., 2008). The disease can either be acute or chronic. Mortality and morbidity rates are high if proper treatments are not given to the infected birds at an early stage (Barrow and Freitas Neto, 2011). Fowl typhoid may cause severe economic loss (estimated 21.13 million CAD \$) when appropriate control strategies are not applied in chicken barns facing a *Salmonella* outbreak (Jain et al., 2019).

As an indispensable trace element in animals, iron plays a key role in numerous biological processes (Ma et al., 2016). It is essential for many life-supporting proteins and enzymes and is highly important for several critical biological processes including respiration, the trichloroacetic acid (TCA) cycle, DNA biosynthesis and others (Andrews et al., 2003). Moreover, iron is the dominant redox active metal in enzymes, though copper and other transition metals are also able to engage in redox reactions (Andreini et al., 2008; Beinert et al., 1997; Bertini et al., 1994). When involved in physiological reactions, iron exists primarily in either the ferrous form or the ferric form (Andrews et al., 2003). Plenty of studies have shown that animals acquire iron mainly from the animal feed. Therefore, iron-supplemented diets are widely used to prevent clinical iron deficiencies and to meet the iron requirements necessary for ideal growth (Ma et al., 2016).

Since most microbial pathogens, including *Salmonella*, require iron to reach the optimal growth and full virulence, the immune system of the host applies different approaches (*e.g.* iron-transferrin signal, hepcidin transcription and degradation of ferroportin) to remove this indispensable element from pathogens (Cherayil, 2011; Ganz

and Nemeth, 2015). To counteract the iron deprivation, *Salmonella* uses specific transporters to obtain iron from the host (Liu et al., 2012; Raffatellu et al., 2009). Studies with mouse models (Deriu et al., 2013; Liu et al., 2012; Raffatellu et al., 2009) have shown that *Salmonella* Typhimurium thrives in the inflamed gut by scavenging for iron with high-affinity iron chelators called siderophores. In this way, this type of *Salmonella* can utilize unique carbon and energy sources and become immune to antimicrobial proteins produced by the host (Thiennimitr et al., 2011; Winter et al., 2010). The role of iron in the physiology, growth, survival, and infection of *Salmonella* has been the subject of numerous reviews (Andrews et al., 2003; Cherayil, 2011; Raffatellu and Bäumlér, 2010). However, its relevance to poultry health has not been reviewed, to the best of our knowledge.

CHAPTER 2 LITTERATURE REVIEW

2.1 BIOLOGICAL ROLES OF IRON IN *SALMONELLA*

Almost all living creatures require a certain amount of iron to survive and reach the optimal growth (Cherayil, 2011). In *Salmonella* and other pathogens, the presence of iron determines multiple pathogenic characteristics and is necessary for virulence (Frawley and Fang, 2014). The adhesion and translocation ability of *Salmonella* could be increased by the presence of iron (Kortman et al., 2012). The invasion ability is also presumably affected by iron (Dostal et al., 2014; Kortman et al., 2012).

The free form of iron within bacteria may be toxic, especially in the presence of reduced oxygen families. Oxygen and superoxide are capable of interacting with the free form of iron to generate radicals through the Fenton reaction, which is extremely harmful to biological molecules (Touati, 2000). Therefore, the biological function of iron almost completely depends on the cooperation with the proteins that form an iron-sulfate cluster and haem group (Andrews et al., 2003).

Some fundamental regulatory proteins in *Salmonella enterica* do not only require iron but are also affected by iron as shown in Table 2.1 (Frawley and Fang, 2014). Ferric uptake regulator (Fur) is a critical iron homeostasis regulator that participates in ferric uptake. It is related to many critical processes of *Salmonella* including invasion ability, mobility and cell filamentation within the macrophage (Leclerc et al., 2017; Leclerc et al., 2013). Deletion or inactivation of the Fur would affect *Salmonella* growth, morphology, and motility (Leclerc et al., 2017). Additionally, the Fur and iron regulate the expression of siderophores (Leclerc et al., 2013).

2.2 IRON HEMOSTASIS IN *SALMONELLA*

Ferrous iron and ferric iron are two major iron sources for bacteria. Iron-containing proteins such as transferrin, lactoferrin, and haem can be used by certain pathogens (Cornelissen and Sparling, 1994; Otto et al., 1990). Under ideal growth conditions for most bacteria, each cell contains approximately 10^5 to 10^6 iron atoms and requires around 10^{-7} to 10^{-5} M of iron (Andrews et al., 2003; Rouf, 1964). Ferrous iron has a relatively high solubility but low stability. In contrast, ferric iron is stable but hardly dissolves in water. Therefore, iron oxides, where iron ions combine with oxygen or sulfur, are the dominant form of iron in nature. Bacteria obtain sufficient iron from the environment in three ways: (1) secreting specific chemicals or proteins to lower the environmental pH which is capable of increasing the solubility of ferric iron; (2) reducing ferric iron to ferrous iron; (3) using some specific chelators as solubilizing agents (Guerinot, 1994). The primary method adopted by *Salmonella* is chelation.

2.3 IRON STORAGE AND UPTAKE IN *SALMONELLA*

Intracellular iron deposits are used to improve growth when environmental iron supplies are depleted or restricted (Andrews et al., 2003). The ferritins are the most common iron storage and antioxidation proteins in all living organisms, including *Salmonella* (Arosio et al., 2009). Dr. Laufberger first discovered and purified crystallized ferritins with cadmium salts in 1937. Ferritins have become the second most-studied iron proteins, falling behind the hemoglobin (Arosio et al., 2009; Laufberger, 1937). The ferritins, characterized by a universal four helical bundle domain, belong to the wide-ranging ferritin-like superfamily which has various functions (Andrews, 2010). Classical ferritins, bacterioferritins, and the 'DNA-binding protein from starved cells' (Dps) are all

classified as subfamilies of the ferritin family (Andrews, 1998; Haikarainen and Papageorgiou, 2010). Ferritins and bacterioferritins consist of 24 subunits each, while Dps contains 12 subunits. A singular haem group is located at the interface between two related subunits with binding ligands towards the inner cavity (Andrews, 2010). The functionality of ferritins and bacterioferritins may vary within different bacteria. For example, the primary iron storage ferritin is classical ferritins in *E. coli* and bacterioferritins in *Salmonella enterica* (Arosio et al., 2017). Ferritins and bacterioferritins share a similar structural property: a nearly spherical protein with a central cavity inside as a storage reservoir (Andrews et al., 2003). The capacity of iron storage among ferritins, bacterioferritins and Dps are dramatically different due to differences in their molecular weight. Ferritins and bacterioferritins have an approximately 500 kDa molecular weight each and are capable of accommodating between 2000 and 3000 iron atoms. In contrast, Dps have a relatively small molecular weight of roughly 250 kDa and only contain around 500 iron atoms (Andrews, 1998). The difference in iron storage capabilities of ferritins, bacterioferritins and Dps could be explained by differences in their functions. Ferritins and bacterioferritins show numerous similarities and both function to store iron. Additionally, Dps are involved in iron homeostasis such as binding DNA against redox stress and free radicals (Almiron et al., 1992). Furthermore, Dps protein is related to pathogenesis and resistance to environmental stress in *Salmonella Enteritidis* (Amano, 2011).

Iron is taken up by iron storage proteins in a ferrous form. However, iron is stored in the ferric form when present in a cavity (Andrews et al., 2003); therefore, ferroxidation is necessary for the storage of iron. For ferritins and bacterioferritins, a highly conserved catalyzed site called the ferroxidase center is located in the central region (Andrews et al.,

2003). Ferroxidase residues of ferritins and bacterioferritins are extremely conserved, acting as ligands for two ferrous iron atoms. After binding with ferroxidase residues, ferrous iron atoms are oxidized by oxygen, forming a di-ferric intermediate (Andrews et al., 2003). Then, the di-ferric intermediate is transported to the central cavity where iron is stored in the form of a ferrihydrite core (non-phosphate) or ferric phosphate core. However, the ferroxidase site of Dps protein that is located at the interface between subunits is not conserved in ferritins or bacterioferritins (Andrews, 2010; Andrews et al., 2003).

2.4 COMPETITION FOR IRON BETWEEN *SALMONELLA* AND THE HOST

Iron is one of the key factors that affects interactions between the host and invading pathogens (Willemetz et al., 2017). Following infection, levels of iron are extremely low in the host environment because of sequestration, a defense mechanism in which iron is bound to proteins including transferrin, and lactoferrin (Andrews and Schmidt, 2007; Weinberg, 1984). Transferrin is an abundant, high-affinity iron-binding protein which rapidly binds to absorbed iron and carries nearly all serum iron (Andrews and Schmidt, 2007). Lactoferrin is a transferrin homologue in many mucosal secretions such as tears and saliva (Jenssen and Hancock, 2009). Lactoferrin is secreted by glandular epithelial cells and has a high affinity to ferric iron at low pH during the inflammation (Deriu et al., 2011). Transferrin and lactoferrin are presented as apo-transferrin and apo-lactoferrin, respectively, when they are not bound with iron in animal bodies. Independent transferrin and lactoferrin receptors have been identified in pathogenic bacteria such as the *Neisseria* species (Cornelissen and Sparling, 1994). These receptors are synthesized and present at the outer membrane when pathogens are faced with iron starvation. Iron is detached with transferrin and lactoferrin at the bacterial cell surface. Afterwards, the apo-transferrin and

apo-lactoferrin are released extracellularly rather than being internalized (Andrews et al., 2003). In order to further limit iron availability, additional strategies are deployed by the host during inflammation (Weinberg, 1984). This includes secretion of hepcidin, also known as hepcidin antimicrobial peptide, a hormone which hinders the gut from absorbing iron from the bloodstream (Ganz, 2003). Hepcidin is a protein consisting of 25 amino acids and is produced by hepatocytes during inflammation and by infected macrophages (Andrews and Schmidt, 2007; Peyssonnaud et al., 2006). Hepcidin is produced primarily by hepatocytes in the liver but can also be produced by the heart, pancreas, and hematopoietic cells (Ilyin et al., 2003; Peyssonnaud et al., 2006) and circulates in the plasma, controlling the trafficking of iron into plasma (Peslova et al., 2009). Apart from inhibiting absorption of iron from the intestine, hepcidin also blocks iron release from the reticuloendothelial macrophages (Cercamondi et al., 2010; Kemna et al., 2008). The mechanism by which hepcidin carries out its iron-reducing mission is by regulating the activity of ferroportin. To our knowledge, ferroportin is the only iron exporter and is responsible for iron release from macrophages, hepatocytes, and enterocytes (Ward and Kaplan, 2012). Therefore, the regulation of ferroportin expression by hepcidin has a central role in iron homeostasis (Deriu et al., 2011). The export of ferrous iron within cells requires ferroportin on the plasma membrane (Peslova et al., 2009). Hepcidin is able to bind to ferroportin of enterocytes, macrophages, and hepatocytes. The intracellular iron retention is regulated by inactivation of ferroportin (De Domenico et al., 2007; Nemeth et al., 2004). It has been found that hepcidin promotes proteasomal degradation of the divalent metal transporter 1 (DMT1) (Brasse-Lagnel et al., 2011). This is supported by evidence that hepcidin deficiency and ferroportin-hepcidin resistance are associated with uncontrolled

dietary iron absorption and progressive iron overload (Ganz and Nemeth, 2011; Sebastiani and Pantopoulos, 2011). The expression of hepcidin is regulated at the transcriptional level, wherein transcription is induced by iron overload, inflammation and endoplasmic reticulum pressure (Pantopoulos et al., 2012). Hepcidin mRNA is strongly upregulated in the liver after exposure of hepatocytes to either lipopolysaccharide (LPS) or the cytokine interleukin-6 (IL-6) (Nemeth et al., 2003, 2004). The expression of hepcidin is known to be induced by IL-6 (Wrighting and Andrews, 2006). Hepcidin is regarded as the central regulatory component of systemic iron homeostasis, which also involves the innate immune system. It has been reported that during *Salmonella* infection, ferroportin gene expression is downregulated in the liver and in cultured macrophages (Ganz and Nemeth, 2015). This observation indicated that cellular iron is critical for the multiplication of *Salmonella* inside the macrophages (Willemetz et al., 2017). However, the exact mechanisms of ferroportin transcriptional regulation in different cell types are unclear and deserve further study.

The iron uptake mechanism of *Salmonella* is shown in Figure 2.1. *Salmonella* develops siderophore in order to scavenge various forms of iron, as shown in Table 2.2 and Table 2.3 (Andrews et al., 2003). As a high-affinity effective iron transporter, siderophore has a low molecular weight (<1000 Da) and a high affinity to the specific form of iron. It can be transformed into an iron-siderophore complex when binding with iron. Based on the functional groups of iron ligands, around 500 siderophores have been characterized and divided into two classes, catechols and hydroxamates (Neilands, 1966; Neilands, 1973). In most circumstances, *Salmonella* synthesizes and secretes siderophores when faced with iron-restricted conditions (Ratledge and Dover, 2000). Ferric chelators are able to

solubilize iron before its transportation. They are the most common type of high-affinity iron carriers secreted by gram-negative bacteria (Andrews et al., 2003). The dominant siderophore of *Salmonella* is enterobactin, a cyclic triester of 2,3-dihydroxy-N-benzoyl serine which belongs to the catechol class and is secreted by almost the entire genus of *Salmonella* (Pollack and Neilands, 1970). Additionally, some *Salmonella* strains produce hydroxamate siderophore aerobactin which is encoded by plasmids (Colonna et al., 1985). Although enterobactin presents in nearly all *Salmonella* isolates, the intermediates, breakdown products, and the ability of secretion vary between subspecies (Aznar et al., 1989; Rabsch and Reissbrodt, 1987; Visca et al., 1991). It has been reported that *Salmonella* possesses a specific uptake system for exogenous siderophores (Luckey et al., 1972). In addition to enterobactin, four other endogenous and exogenous siderophores from *Salmonella* have been discovered: 2,3-dihydroxybenzoic acid (DHBA), linear 2,3-dihydroxybenzoylserine, myxochelins, and aconitins (Kingsley et al., 1995). Interestingly, DHBA is not only an intermediate during enterobactin but is also a growth factor in collaboration with other endogenous aerobactin when *Salmonella* is faced with iron starvation (Rabsch et al., 1986; Rabsch et al., 1991). Furthermore, a recent study in *Klebsiella pneumoniae* shows that siderophores are able to interact with host cells, increasing the expression of interleukin-6 (IL-6) and promoting dissemination of *Klebsiella pneumoniae* to the spleen (Holden et al., 2016). This may be evidence that siderophores could have multiple functions.

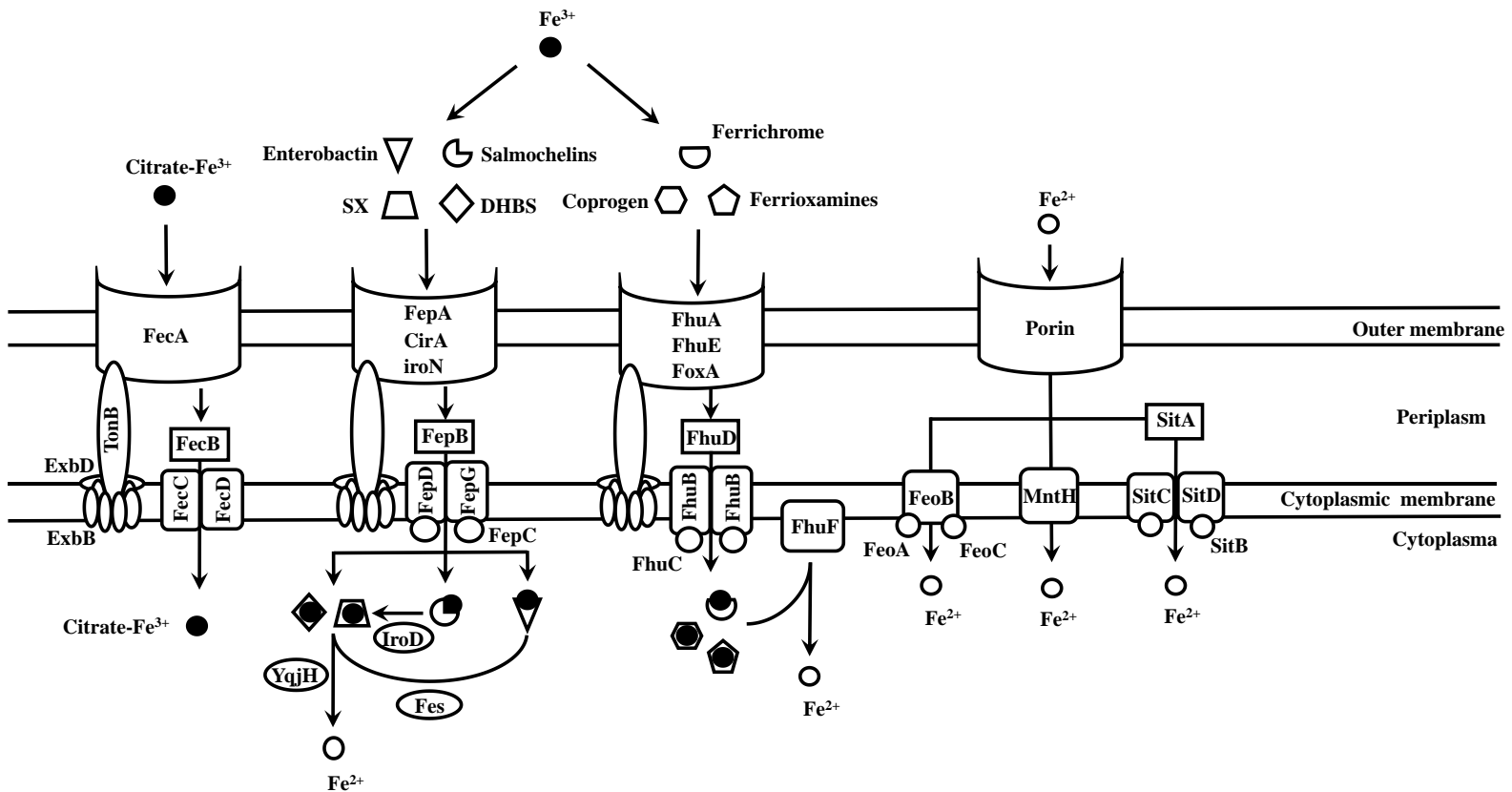

Figure 2.1 Postulated iron-uptake mechanism of *Salmonella* species. According to the similarity of the pathway of uptaking ferric iron, ferric receptors are classified into two groups, IroN, FepA, CirA and FhuA, FhuE, FoxA. In the group of IroN, FepA, CirA, IroN is able to recognize all of the four siderophores including enterobactin, salmochelins, DHBS and SX. FepA can accept all of the siderophores, except for salmochelin. CirA is only capable of recognizing DHBS and SX. In the other group, FhuA, FhuE, and FoxA are designed for

ferrichrome, coprogen, and ferrioxamines, respectively. All of the six receptors are TonB-dependent transporters. The transporting process requires energy in the form of proton motive force. The three inner membrane protein complexes (TonB-ExbB-ExbD) are able to transduce this energy to the outer membrane. FepB and FhuD are periplasmic proteins which are required for transporting the iron complex to the cytoplasm. After the iron complex is transported into the cytoplasm, salmochelins and enterobactin interact with siderophore esterases IroD and Fes, respectively, and finally degrade to DHBS and SX. The ferric iron is reduced by NADPH-dependent ferric-chelate reductase and the ferrous iron detached from DHBS and SX. Ferric iron reductase protein (FhuF) reduces iron in the ferrichrome, coprogen, and ferrioxamines. In the aspect of an organic iron source, such as ferric citrate, the Fec iron-uptake system (FecABCD) contributes to the uptake of ferric citrate in the bacterium, acting similarly to siderophore uptake pathways. H⁺-stimulated divalent metal cation transporter Mnth, GTP-driven Fe²⁺ uptake system (FeoABC) and SitABCD metal transport system are all known ferrous transport systems. The ferrous iron enters the bacterial periplasm through the beta-barrel protein porin. The periplasmic ferrous iron is either accepted or transported by the FeoABC system and Mnth, receptor or captured by the SitA metal binding protein and transported through the SitABCD system.

Due to the size of iron-siderophore complexes, there is an abundance of different iron-siderophore receptors located on the outer membrane of *Salmonella* helping them pass through the outer membrane (Andrews et al., 2003). The receptors on the outer membrane have an extremely high affinity (K_d 0.1- 100 nM) to their corresponding iron-siderophore complex (Stintzi et al., 2000). All of the discovered outer membrane iron-siderophore receptors are related and cross-linked. FepA, FecA, and FhuA are the most highly studied receptors in crystal structure and function (Buchanan et al., 1999; Ferguson et al., 2002; Ferguson et al., 1998; Köster, 2001). In addition, one study shows that the expression of *iroN* not only requires the transcriptional depression of *fur* but also the activation of homologous, non-coding small RNAs, RyhB1 or RyhB2 (Balbontín et al., 2016). The number of siderophore receptors is dramatically decreased when *Salmonella* grows under iron-sufficient conditions compared with iron-limited conditions (Andrews et al., 2003). One of the explanations for this is that siderophore receptors may be a potential target of bacteriophages and antibiotics as an entrance into the bacterial cell.

Transportation of iron-siderophore through the receptor is an energy-consuming process. The energy comes from the TonB-ExbB-ExbD protein complex which can generate an electrochemical charge gradient between the cytoplasmic membrane and the outer membrane (Higgs et al., 1998; Larsen et al., 1994). The mechanism of the TonB-ExbB-ExbD protein complex is best known in *Escherichia coli*. Recently, an *in vivo* study found a new ligand-independent interaction between FepA and TonB, which may explain how FepA signals to TonB (Gresock and Postle, 2017). Similarly, another study shows that the gating mechanism of TonB-dependent transporters relates to substrate-specific forced remodeling (Hickman et al., 2017). Although *Salmonella* shares a similar TonB-ExbB-

ExbD protein-driven system to *E. coli*, the details of the mechanism in TonB discrimination between different TonB-dependent transporters and TonB-dependent energy transduction remains opaque.

The periplasmic binding protein (PBP) serves as a shuttle to help iron-siderophore complexes across the periplasmic space and cytoplasmic membrane (Andrews et al., 2003). One iron-siderophore is carried by one periplasmic binding protein for each crossing until it is released to the corresponding permease on the cytoplasmic membrane. In the uptake of ferric citrate, it has been reported that the periplasmic binding protein FecB is able to bind with citrate complexes containing trivalent and metal-free citrate (Banerjee et al., 2016). As an essential part of bacterial enterobactin uptake, FepB transport ferric-enterobactin (Fe-Ent) from the outer membrane to the inner membrane permease-ATPase type transporter (FepD/FepG). Unlike other PBP, FepB captures 4 Fe-Ent complexes to form a trimer (Li et al., 2016). However, it is still unclear whether iron-siderophores are directly transferred to a periplasmic binding protein through the outer membrane receptor or if iron-siderophores are free inside the periplasm and then picked up by the periplasmic binding protein (Köster, 2001). One of the periplasmic binding proteins, FhuD, is found to be evolutionarily involved in the binding of iron-siderophores and maintains identical functions in different gram-negative bacteria. A recent study shows that FhuD is strong and stable when it binds to ferrichrome, therefore increasing the thermostability in *Staphylococcus pseudintermedius* (Abate et al., 2016). However, the protein structure and possible exclusive function of FhuD in *Salmonella* are still unclear.

Cytoplasmic membrane permease proteins and the ATP-Binding Cassette (ABC) protein are two major components of the ABC permease complex located on the inner

surface of the cytoplasmic membrane in most of the gram-negative bacteria (Andrews et al., 2003). The cytoplasmic membrane permease component can be constructed with two independent subunits of FepD and FepG, or a large subunit FhuB, despite the fact that ABC components consist of two interchangeable subunits. Several reports have shown that ABC permease complexes are able to interact with their agnate periplasmic binding proteins such as FhuD. A subunit of FhuB can be cross-linked during the binding process. A large amount of FhuB peptides are capable of binding to purified FhuD and FhuB is protected by FhuD from proteolysis (Mademidis et al., 1997; Rohrbach et al., 1995). The major ferrous iron transport system in many bacteria is the Feo system. It has been reported that FeoA, FeoB, and FeoC are able to form a large inner membrane complex *in vivo* and FeoA is essential in the process of Feo complex assembly in *Vibrio cholerae* (Stevenson et al., 2016). However, the structure and mechanism of the FeoABC iron transport system have not been determined. The exact number of different types of ABC permease in *Salmonella* remains unknown. The corresponding relationship between the binding proteins and permease complexes are also unclear; for instance, whether the binding is one-to-one or one-to-many.

After the iron-siderophore passes through the cytoplasmic membrane, iron must be dissociated from the siderophore before it is used for cellular metabolism (Andrews et al., 2003). Several intracellular ferric reductases are involved in the dissociation process of the ferric-siderophore, ultimately making the ferric-specific siderophore separate from the iron due to its relatively low affinity to ferrous (Andrews et al., 2003).

2.5 EFFECT OF IRON ON THE INFECTION OF *SALMONELLA*

2.5.1 Models to study *Salmonella* infection

Human colorectal adenocarcinoma Caco-2 cells can be studied, thus offering a popular

in vitro model of explaining the interaction between *Salmonella* and human (Finlay and Falkow, 1990). More specifically, well-differentiated Caco-2 cell monolayer with microvilli could mimic human intestinal mucosal barrier in the *in vitro* condition (Neutra, 1989; Peterson and Mooseker, 1992). Recently, plenty of new knowledge regarding the pathogenesis of *Salmonella* have been generated by using Caco-2 cells. Salehi et al. (2017) report that flagella are required for *Salmonella* adhesion and invasion to broiler skin and Caco-2 cells, respectively. *Salmonella*-infected Caco-2 cells could increase the expression of programmed death ligand 1 protein, which facilitate the immune evasion of pathogen-infected cells (Sahler et al., 2018). Chakroun et al. (2018) study the mechanism of motility, biofilm formation, and apoptosis of *Salmonella* Typhimurium by using Caco-2 cells. One of the primary strategies applied by *Salmonella* to neutralize host defense and biofilm formation is essential for the survival of *Salmonella* in rough environment (Chakroun et al., 2018).

C. elegans is a convenient animal model that has been widely used in many fields including drug development, cell signaling, toxicity testing and host-pathogen interaction (Hsin et al., 1999; Hunt, Piper Reid 2017; Tan et al., 1999). There are plenty of advantages of using *C. elegans*: 1) *C. elegans* have a short life-span and they are easy to handle; 2) there are thousands of available mutant strains; 3) *C. elegans* have numerous gut granules that may mimic the gut environment of animals (Chase et al., 2007). Negi et al. (2018) used *C. elegans* to investigate the host response to the *Salmonella* infection and reported that amyloid- β protein plays a protective role in innate immunity. Head et al. (2017) reported that GATA transcription factor ELT-2 and p38 MAPK pmk-1 are essential for the recovery process when *C. elegans* is faced with an acute *Pseudomonas aeruginosa* infection.

Recently, *C. elegans* have been used as a model to investigate the effect and mechanism of functional food and probiotics against pathogens. Kulshreshtha et al. (2016) reported that red seaweeds *Sarcodiotheca gaudichaudii* and *Chondrus crispus* could enhance the expression of immune responsive genes of *Salmonella*-infected *C. elegans*. Zhou et al. (2018) revealed that *Lactobacillus zae* could regulate the p38 MAPK and DAF/IGF pathways of *C. elegans* and enhance the production of antimicrobial peptides against Enterotoxigenic *Escherichia coli* infection.

2.5.2 Infection mode of *Salmonella*

Pathogenic invasion and penetration of the intestinal epithelium of the host is the first step of developing a *Salmonella* infection (Shi and Casanova, 2006). After being taken in by the animal and entering the small bowel, *Salmonella* reaches and passes over the intestinal mucus layer. When the infected host is a mammal, *Salmonella* prefers to adhere to microfold cells of Peyer's patches in the intestinal epithelium; however, attachment to other nonphagocytic epithelial cells is also observed (Jones et al., 1994; Takeuchi, 1967). A short moment after adhesion, the bacterial invasion begins with cytoskeletal rearrangements of the target epithelial cell through the interaction with the molecules in the signaling pathways of the host cell (Finlay et al., 1991; Francis et al., 1992). *Salmonella*-containing vacuoles (SCVs) are formed through these intracellular rearrangements that lead to engulfing attached *Salmonella* into large vesicles by epithelial brush and membrane ruffles (Francis et al., 1993; Garcia-del Portillo and Finlay, 1994). *Salmonella* cells can survive and replicate when they are inside the SCVs. Meanwhile, phagocytes are recruited from intestinal epithelium by a secretory response, and then they transmigrate from the submucosal space to the intestinal lumen (Fàbrega and Vila, 2013).

Tumor necrosis factor alpha, interleukin-8, and many other proinflammatory cytokines are produced during this process (Hobbie et al., 1997). The SCVs are blended into the molecules of the early endocytic pathway during the early stage of invasion. However, *Salmonella* is able to change the endocytic trafficking of the host cell, which helps it bypass the fusion with lysosomal enzyme and secondary lysosomes (Garcia-del Portillo and Finlay, 1995; Rathman et al., 1997). During the maturation of SCV, vacuole-associated actin polymerization, a process where F-actin covers the entire surface of SCV, is performed by *Salmonella* to support and maintain the integrity of SCV (Méresse et al., 2001). In the next stage, the SCVs migrate to a position near the nucleus cell and Golgi apparatus. Hypothetically, this event assists *Salmonella* in intercepting endocytic transport vesicles and obtaining nutrients, which are crucial for bacterial replication (Deiwick et al., 2006; Salcedo and Holden, 2003). Additionally, *Salmonella*-induced filaments (SIFs), which are long filamentous tubular aggregates attached to microtubules of the host cell, are developed from SCVs throughout the cell and also obtain nutrients (Garcia-del Portillo et al., 1993b; Knodler et al., 2003; Rajashekar et al., 2008). Liss et al. (2017) found that *Salmonella enterica* was able to convert the host endosomal system into a network of *Salmonella*-induced filaments. Bacterial metabolic activity, intracellular replication ability, and nutrient accessibility were improved when *Salmonella* connected to a SIFs network (Liss et al., 2017). Once the SCVs pass through the basolateral membrane of the intestinal epithelium, a large number of macrophages, neutrophils, and dendritic cells are waiting to engulf the SCVs immediately (Fàbrega and Vila, 2013). A type III secretion system (T3SS) encoded by *Salmonella* pathogenicity island-2 is vital for bacterial survival inside the macrophages (Chakravorty et al., 2002). Effector proteins 1 and effector proteins 2 secreted from SCVs

to macrophages through T3SS enable *Salmonella* to survive (Uchiya and Nikai, 2012). In addition, it has been found that enterobactin is able to affect the immune and nitrosative response of macrophages by inhibiting the secretion of cytokines (i.e., serum amyloid A, IL-6, lipocalin 2) and upregulating the expression of iNOS (mRNA, protein) and Arginase-1 (mRNA) (San Yeoh et al., 2017). SCVs-containing phagocytes aid in the process of disseminating *Salmonella* to several organs and tissues via the bloodstream causing systemic dissemination (Alpuche-Aranda et al., 1994). A recent study shows that tissue and cellular iron distribution of the host determine the susceptibility to infection with *Salmonella* (Nairz et al., 2017).

Kogut and Arsenault (2017) outlined three distinct stages of the processes of *Salmonella* infection in chickens as follow: disease resistance (1 to 2 days post-infection), disease tolerance (4 days post-infection) and homeostasis (5 to 10 days post-infection). The stages are categorized by the activities of cecal immune effector cells, expression of immune-related genes, and immune-metabolic responses of post-infection: 1) an acute heterophil-mediated pro-inflammatory response and anabolic metabolism are found in the disease resistance stage birds; 2) infected birds in the disease tolerance stage convert to the catabolic phenotype and show an intense increase in the cecal T regulatory cells and anti-inflammatory response; 3) birds in the homeostasis stage get back to a homeostatic metabolic phenotype with increased immune response mediated by IL-10- regulatory (Kogut and Arsenault, 2017).

Overall, *Salmonella* undergoes several processes and environmental changes before causing infection (Uchiya and Nikai, 2012). *Salmonella* first encounters an acidic environment in the stomach, and then reaches the intestine to proceed with the adhesion

and invasion of epithelial cells and M cells located in Peyer's patches (Garcia-del Portillo et al., 1993a). Host cells secrete diverse cytokines and chemokines to help polymorphonuclear leukocytes move to infected tissues and express cytotoxic granules to antagonize *Salmonella*, where inflammation is induced (Uchiya and Nikai, 2012). After enduring phagocytosis by macrophage cells and neutrophil cells, *Salmonella* is able to migrate to the spleen and liver through lymphatic vessels and blood circulation leading to systematic infection (Fàbrega and Vila, 2013; Uchiya and Nikai, 2012).

2.5.3 Iron concentrations and the growth and infection of *Salmonella*

The iron content of most bacteria is approximately within the range of 10^5 to 10^6 iron atoms per cell, depending on the growth environment (Andrews et al., 2003). In general, 10^{15} iron atoms per milliliter are expected to be consumed for each generation of bacteria when cultured in ideal conditions (Braun et al., 1998). There is strong evidence that increasing iron availability can improve the adhesion, invasion and virulence abilities of *Salmonella* (Dostal et al., 2014; Kortman et al., 2012; Kortman et al., 2014). Numerous strategies are applied by *Salmonella* to acquire iron and survive inside the macrophage. It has been found that the iron exporter ferroportin mRNA expression of the *Salmonella*-infected macrophage is downregulated to provide sufficient cellular iron for the growth of *Salmonella* inside the macrophage (Willemetz et al., 2017). Similarly, another study showed that hepcidin level was increased by an *Salmonella* Typhimurium infection through a toll-like receptor 4 (TRL-4) dependent mechanism in the liver (Moreira et al., 2017). In addition, it has recently been found that both *Salmonella* and high dietary iron could alter iron distribution in the spleen, serum and liver causing splenic Fe loss in hens (Machado et al., 2016; Bai et al., 2018). A high iron diet could also decrease the abundance of potentially

beneficial *Lactobacillus* (Lin et al., 2018). However, it is not yet understood whether the downregulation of the ferroportin (FPN) expression exists in different macrophages populations, and what is the optimal iron concentration scale for an ideal growth condition for *Salmonella*.

When the host is infected, an iron withholding strategy is activated by the host to decrease the iron concentration in the body and limit the access of iron to pathogens (Cassat and Skaar, 2013; Nairz et al., 2010). This innate immune defense begins with upregulation of hepcidin during the early stage of infection and inflammation, which is able to reduce dietary ferric uptake in the duodenum and degrade FPN (Cassat and Skaar, 2013; Frawley and Fang, 2014). Then, proinflammatory cytokines inhibit the absorption of ferrous iron by mediating the DMT1 and upregulating transferrin synthesis to scavenge extracellular iron (Cassat and Skaar, 2013; Frawley and Fang, 2014). This event further limits the free iron that can be used by pathogens in the host. After SCVs are engulfed by macrophages, the transferrin receptor is downregulated to limit the iron uptake of macrophages. The natural resistance-associated macrophage protein 1 helps to remove iron from the phagosome which could be a challenge to *Salmonella*. Moreover, Lipocalin 2 (Lcn2) produced by neutrophils is able to stabilize the siderophore-bound labile iron pool in infected cells and inhibit the interaction of bacterial siderophore-iron acquisition (Cowland and Borregaard, 1997; Xiao et al., 2017). However, counter-strategies are applied by *Salmonella* to neutralize Lcn2; *Salmonella enterica* modifies its Ent via C-glycosylation to generate salmochelin, which cannot be sequestered into the Lcn2 calyx due to steric hindrance from the glucose groups (Fischbach et al., 2006).

2.5.4 Iron forms and the growth and infection of *Salmonella*

About 60% to 70% of body iron is found in hemoglobin (Uchiya and Nikai, 2012). For mammals, birds, and reptiles, less than 1% of the total iron content exists in body fluids, which does not meet the iron level content required for *Salmonella* growth (Kingsley et al., 1995). Hence, heme, hemoglobin and other iron binding proteins (e.g. transferrin) are the main iron forms from the host that are targeted by *Salmonella*.

Intracellular pathogens develop the following strategies to acquire iron: (1) high-affinity siderophores, transferrin binding proteins and lactoferrin binding proteins are secreted to obtain intracellular iron; (2) heme or the hemoprotein receptor is utilized to interrupt iron homeostasis of the host cell, increasing iron availability; (3) transferrins are captured by pathogens through endocytosis (Cassat and Skaar, 2013; Collins, 2003; Kingsley et al., 1995; Wooldridge and Williams, 1993). A study shows that the iron concentration of SCVs containing Madin-Darby canine kidney cells is around 1 μM which is relatively low but still induces the expression of virulence genes (Wooldridge and Williams, 1993). Some studies show that the virulence of *Salmonella* is unrelated to high-affinity siderophores based on the iron uptake system (Benjamin et al., 1985; Braun et al., 1998). However, other epidemiological evidence and animal experiments support the hypothesis that iron is related to the virulence of *Salmonella* (Furman et al., 1994; Sawatzki et al., 1983). The exact iron acquisition pathways and their mechanism deployed by *Salmonella* is unclear.

2.5.5 Iron amino acid chelates and the growth and infection of *Salmonella*

Ferrochel, iron glycine chelates (Fe-Gly) and ferric ethylenediaminetetraacetate acid are potential iron sources for the fortification of foods due to their high bioavailability

(Yeung et al., 2005). Iron chelators are easily absorbed by animals. Studies indicate that ferrous bisglycinate and Fe-Gly have a higher absorption rate, compared with typical iron salts such as ferrous sulfate in cell culture (Ma, 2013; Yeung et al., 2005). An *in vivo* experiment reveals that ferrous bisglycinate is more effective than ferrous sulfate in weaning infants (Fox et al., 1998). Interestingly, a study found that Fe-Gly has an antibacterial effect against several gram-negative bacteria such as *E. coli* (Kudrat-E-Zahan et al., 2015). Another study reports the antibiotic properties of ferric EDTA to *Trichoderma hamatum* (Hubbard et al., 1983). However, there is little evidence about the effect of these iron chelators on the growth of *Salmonella*. The antibacterial mechanism of Fe-Gly and Ferric EDTA remains unknown.

Synthetic iron chelators like desferrioxamine and PAI-DHBA, which have an extremely high iron affinity, are able to sequester iron from *Salmonella* (El-Gendy et al., 2015; Van Asbeck et al., 1983). The decrease of bacterial growth is observed in the PAI-DHBA treatment. Moreover, deferoxamine is used for iron chelation therapy for iron overload patients who are more susceptible to *Salmonella* infection (Baldus et al., 1978; Cassat and Skaar, 2013). Apart from these synthetic chelators, increasing attention has been drawn to the natural plant-based iron chelator in recent years. A study shows that a flavonoid-rich extract from bergamot and orange juice was able to chelate Fe^{3+} and protect against oxidative damage induced by Fe^{3+} (Ferrlazzo et al., 2016). In addition, Lane et al. (2017) found that root exudates from *Populus trichocarpa* shared a chelation ability similar to iron chelator EDTA. However, the components of plant extracts and exudates remain unclear as well as the potential inhibitory effect of natural iron chelators on pathogens.

2.6 REGULATION OF IRON ABSORPTION AND METABOLISM IN POULTRY

2.6.1 Iron deficiencies

The iron requirement in poultry vary between breeds, as shown in Table 2.4. According to the National Research Council (1994), 80 mg/kg of Fe dry matter is recommended in the diet of broiler chickens. Despite maize- and soybean-based diets containing more than 80 mg/kg of Fe, the presence of phytic acid can reduce the availability of inorganic iron (Bess et al., 2012; Sun et al., 2015). Due to low bioavailability, high excretion, and hydroscopicity, supplementation of iron to a poultry diet is always inadequate (Ma et al., 2014). Iron deficiency-induced anemia with a reduction in packed cell volume is the most common iron metabolism-related disease globally (Lieu et al., 2001). In color-feathered strains of birds, iron is indispensable in many catalytic processes and complicated with melanin in various feather pigments (McGraw, 2003; Niecke et al., 1999). Iron deficiencies in birds cause loss of pigmentation in the feathers.

2.6.2 Dietary iron forms

Heme iron and non-heme iron are the two forms of iron in diets. In general, heme iron is highly available for animals and most frequently found in animal protein ingredients such as meat bone meal and fish meal (Bess et al., 2012). Heme iron binds with proteins in the form of hemoglobin and myoglobin (López and Martos, 2004). Hemoglobin and myoglobin account for a relatively small portion of absorbed dietary iron but they are less affected by other dietary factors (López and Martos, 2004; Schönfeldt and Hall, 2011). Non-heme iron is regarded as an inorganic form of iron derived from vegetables, fruits, and beans. Considering the economic cost, inorganic iron sources such as ferrous sulfates are widely used in the formulation of broiler breeder diets (Bess et al., 2012). Due to the

difference in ligands and several physiologic factors, the absorption rate of inorganic iron in most vegetables is much less than that of heme iron (Charlton and Bothwell, 1983; López and Martos, 2004). More evidence has been found that tannins, polyphenols, and phytates are responsible for the poor bioavailability of non-heme iron (Charlton and Bothwell, 1983; Davies and Nightingale, 1975). In addition, chelated minerals such as iron amino acid chelates are considered to have high solubility and stability in the gastrointestinal tract due to their chemical form (Vieira, 2008).

In recent years, organic iron products such as iron amino acid chelates and hydrolyzed proteins, have been developed as alternatives to traditional inorganic iron supplements (Ma et al., 2014). Many studies show that organic Fe supplementation such as iron amino acid chelates has higher bioavailability and better productive performance compared with traditional inorganic iron supplementation (Jarosz et al., 2016; Kochetkova et al., 2016; Li et al., 2017). Furthermore, the study of Khattak et al. (2018) shows that TYPLEX® Chelate (ferric tyrosine) was able to inhibit colonization and biofilm formation of *Campylobacter jejuni* in broiler chickens. Other studies indicate that increased deposition of iron in broiler meat and eggs is related to the use of iron-methionine chelates (Park et al., 2004; Seo et al., 2008). However, it has been reported that the efficacy of organic Fe products in animals is inconsistent compared to that of inorganic Fe. Some early studies show that organic Fe sources are more available than inorganic Fe sources (Spears et al., 1992; Yu et al., 2000). This inconsistency may be due to the quality of the organic Fe sources, the indices and methods of Fe bioavailability evaluations, or the type of basal diets used in the studies.

2.6.3 Systematic iron balance

The different forms of iron involved in the systemic iron balance in different organs are

shown in Figure 2.2. Almost all of the iron present in the form of heme. Hemoglobin of erythroid cells and myoglobin of muscles cells are the two proteins contain the majority of heme. Macrophages in the spleen, liver and bone marrow preserve a minimum amount of iron, while the ferritin, hemorrhage could store part of the excess iron, and other losses

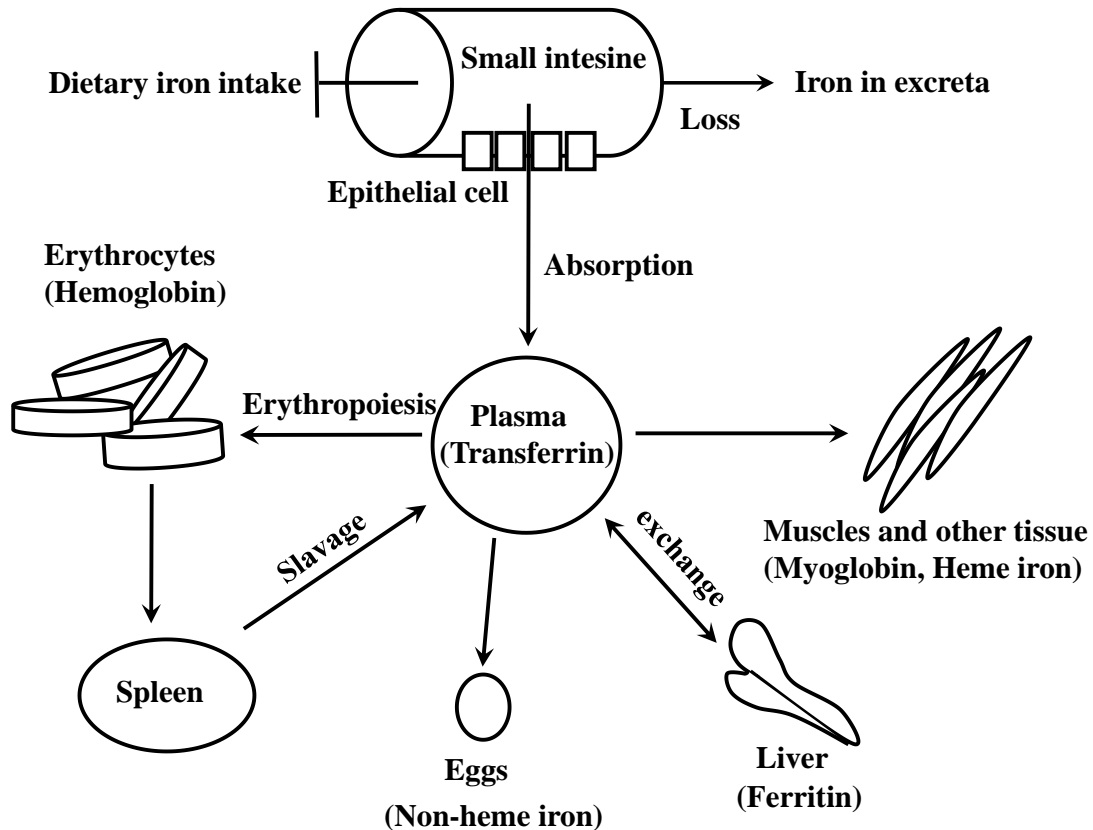

(Pantopoulos et al., 2012). Splenic reticuloendothelial macrophages can recycle iron from aging red blood cells and the recycled iron could be utilized for the synthesis of new red blood cells (Pantopoulos et al., 2012). Transferrin delivers iron to the tissues and cells where iron is required such as developing erythroid precursors. Liver hepatocytes store iron in ferritin shells (Pantopoulos et al., 2012). Iron deficiency and iron overload could significantly affect the absorption, distribution and recycling of iron in the animal (Pantopoulos et al., 2012).

Figure 2.2 Iron uptake, circulation, and recycling in poultry. Organs and forms of iron involved in the systemic iron balance are shown. Most of the iron in animals is present in the form of hemoglobin. Bone marrow and mature erythrocytes are sites where hemoglobin is largely found. Duodenal enterocytes absorb dietary iron. Iron was delivered to erythroid precursors, cells and tissues for iron utilization by transferrin. A portion of iron involves in erythropoiesis process existing in the hemoglobin. Iron recycling occurs when senescent red blood cells are engulfed and lysed by splenic reticuloendothelial macrophages. The recycled iron is available for the synthesis of new red blood cells. Liver hepatocytes store iron in ferritin shells. Additionally, iron in the layer's body is transported to eggs and stored in non-heme forms.

2.6.4 Intestinal iron absorption

The postulated mechanism of iron absorption in poultry is shown in Figure 2.3. The most iron absorption activity in mammals occurs in the proximal duodenum and upper jejunum (Wheby, 1970). For poultry, the major site for Fe absorption is the duodenum, which is similar for humans (Li et al., 2017; Sturkie, 2012). Ferric reductases such as duodenal cytochrome b (DcytB) on the apical brush border of intestinal epithelial are able to reduce ferric iron to ferrous (Pantopoulos et al., 2012). The DMT1, also known as the natural resistance-associated macrophage protein 2 or the divalent cation transporter, belongs to the solute carrier family 11 members 2 (SCF11M2). DMT1 transports ferrous across the apical membrane (Hentze et al., 2010; Wang and Pantopoulos, 2011). When ferric iron and ferrous iron arrive at the duodenal brush border membrane, the redox system which is predominantly the DcytB, begins to operate and reduce the ferric Fe to ferrous Fe that can be transported into the enterocyte by DMT1 (Jordan and Kaplan, 1994; Raja et al.,

1992). Within the cell, Fe is either stored as ferritin or exported into circulation by the coordination of FPN and hephaestin (Tako et al., 2010). Ferric iron is then associated with transferrin for distribution throughout the body via the plasma circulation system (Collins et al., 2005). Heme iron is taken up by the duodenal mucosal cell via endocytosis. A different method is applied for the uptake of heme iron (Hallberg, 1981). The process of intaking heme is facilitated by the vesicular transport system when heme binds to the haem carrier protein 1 (HCP1) (Hooda et al., 2014; Shayeghi et al., 2005). Intracellular heme are metabolized by Heme oxygenase 1 (HO-1), present on the endoplasmic reticulum, and Heme oxygenase 2, present on the vesicle membrane after which iron is released (Hooda et al., 2014). Intracellular heme can be released to the blood through the heme exporter. Mucous intestinal cells absorb heme iron as an intact metalloporphyrin after hemoglobin is digested by several enzymes (Gräsbeck et al., 1982). Ferrous iron is released from absorbed haem by HO-1 subsequently. This unique uptake process might account for the fact that heme iron has a high absorption rate (Wang and Pantopoulos, 2011). It has been reported that HO-1 participate in the early control of *Salmonella* infection in a macrophage with the heme oxygenase gene strongly upregulated (Mitterstiller et al., 2016).

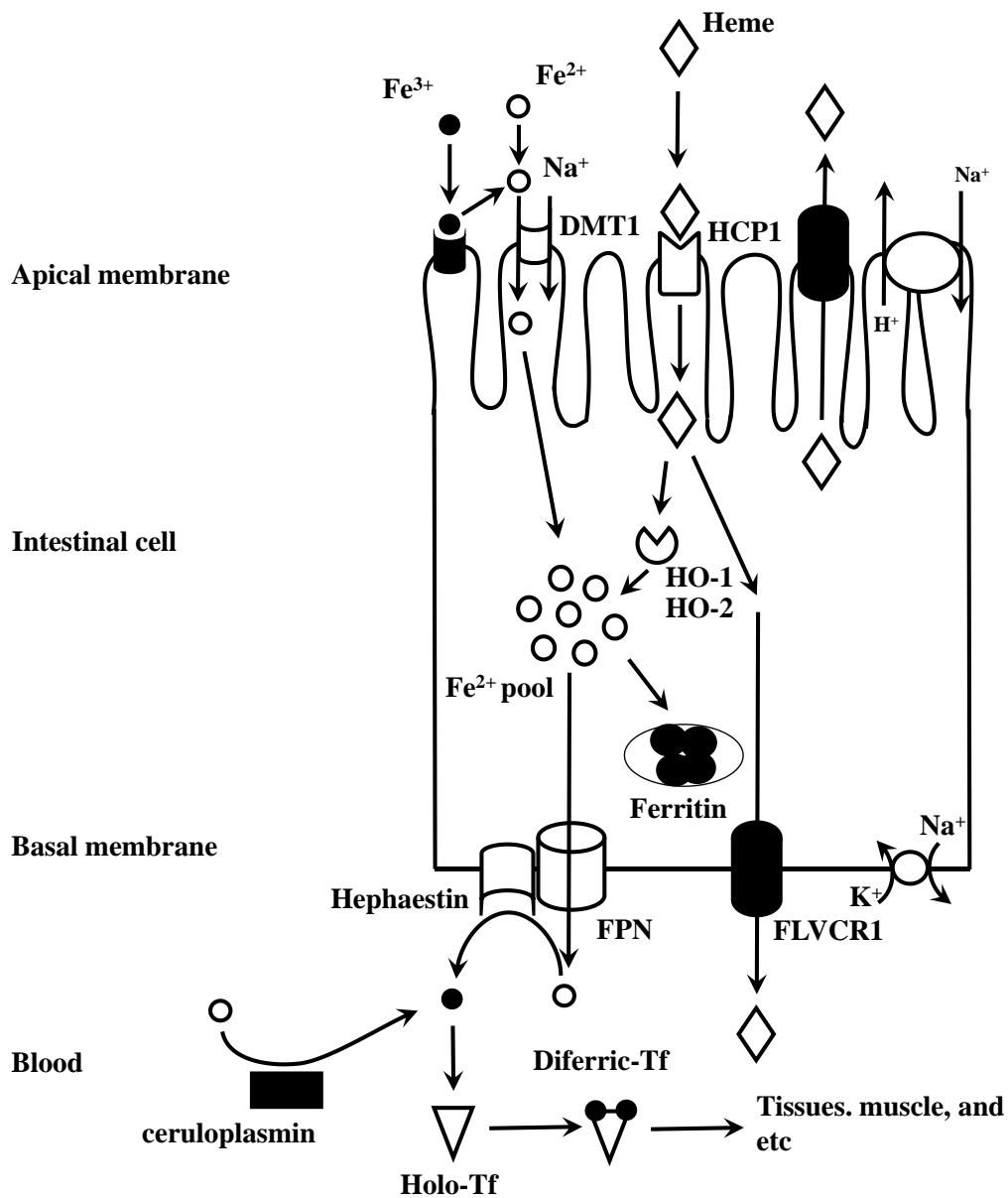

Figure 2.3 The postulated mechanism of iron absorption in poultry. Duodenal enterocytes uptake ferrous iron by the DMT1 receptor located on the apical surface. Ferric reductase, DcytB, can bind with luminal Fe^{3+} and reduce Fe^{3+} to Fe^{2+} . Specific transporters such as haem carrier protein 1 (HCP1) exist for heme on the surface of enterocytes. After binding to its receptors, the heme molecule is internalized, then releases the iron to the labile Fe^{2+}

pool through interaction with heme oxygenase (HO-1, HO-2). A few of the heme molecules are exported to blood through the feline leukemia virus subgroup C cellular receptor 1 (FLVCR1). In a heme-overload situation, excess heme can be transported back to the intestinal lumen. Soluble intracellular Fe^{2+} is either inserted into ferritin or exported through the only known iron transporter on the basolateral membrane, the FPN. The intracellular iron was transported to the blood stream by FPN. Exported Fe^{2+} can be oxidized into Fe^{3+} by hephaestin. Holo-Tf in the plasma captures free Fe^{3+} and circulates iron in the body. Iron is also oxidized by ceruloplasmin in the circulation.

2.6.5 Regulation of intestinal iron absorption

Iron absorption depends on two factors: the intake amount of bioavailable iron and the iron status in the animal body. If animals are in a state of iron deficiency, the absorption rate of dietary iron increases until the percentage of absorbed iron reaches a satisfied level (Bothwell et al., 1979; Cook et al., 1974; Pirzio-Biroli et al., 1960). When the body is deficient in the synthesis of functional iron-containing proteins such as hemoglobin, the iron absorption rate rises as the condition of anemia increases (Norrby and Siilvell, 1974).

The mechanism of regulation of intestinal iron absorption is controversial. Some studies show that a direct relationship is built between iron absorption and the synthesis of erythropoiesis exists (Bothwell et al., 1979). However, the iron absorption rate in humans experiencing chronic hemolytic states is normal (Bothwell et al., 1979). The most plausible hypothesis is that iron absorption is regulated by the iron content in individual tissues (Cavill et al., 1975). All body tissues have a labile pool of iron which is available to transferrin and the size of the pool reflects the amount of iron being stored in tissues (Charlton and Bothwell, 1983). Therefore, an increase of iron uptake in the duodenum may

result from a decrease of iron content in the pool and decreased erythropoietic activity (Charlton and Bothwell, 1983). Several pieces of evidence supporting this hypothesis are found in rats. A rapid increase in iron delivery is observed from the tissues when transferrin requires more iron (Finch et al., 1982). The iron absorption rate is not regulated by the iron content in plasma or the percentage of unsaturated transferrin (Charlton and Bothwell, 1983).

Different iron sources can also affect iron absorption in poultry. Some organic Fe sources (e.g. Fe amino acid chelates, complex and Fe proteinates) have been used as iron supplementation in poultry feeds. Some studies found that the bioavailability of organic Fe sources for broilers is high because the high chelation strengths between Fe and ligands could facilitate the iron absorption (Ma et al., 2014; Zhang et al., 2016). However, kinetic studies have shown that the absorption of organic and inorganic Fe is through the same saturated carrier-dependent transport process, and that DMT1 and FPN may be involved in Fe absorption in the duodenum of broilers regardless of the iron form (Zhang et al., 2017).

2.6.6 Regulation of iron metabolism

Iron homeostasis in animals can be described as an elaborate cooperative effort among four intensively related sections: dietary iron absorption, systemic iron regulation, iron recycling and iron utilization (Pantopoulos et al., 2012). Heme and non-heme iron are absorbed by duodenal enterocytes. Splenic macrophages recycle iron by engulfing senescent or dead red blood cells with the involvement of HO-1 (Pantopoulos et al., 2012). For splenic macrophages and intestines, FPN is the only transportation protein that exports intracellular iron to plasma. Ferrous iron is oxidized to ferric iron immediately with the assistance of hephaestin on plasma membrane after it is transported via FPN. Moreover,

ceruloplasmin within the circulation is designed to oxidize ferrous iron that does not bind with hephaestin (Pantopoulos et al., 2012). Plasma transferrin captures the released ferric iron in circulation, forming ferric transferrin. Iron is carried on diferric-transferrin during transportation to different tissues and cells like skeletal muscle and erythroblast. Thereafter, diferric transferrin binds with the transferrin receptor on the plasma membrane surface of iron utilized cells (such as myocyte), and uptake is through an internalization process (Pantopoulos et al., 2012).

2.7 APPLICATION OF IRON METABOLISM IN THE CONTROL OF *SALMONELLA* IN POULTRY

Extensive research has been conducted on iron modulation as a potential weapon against *Salmonella* in mice (Chanana et al., 2004; Nairz et al., 2015; Weinberg, 1992; Willemetz et al., 2017; Kortman et al., 2012; Moreira et al., 2017). However, only a few studies have been conducted on the relationship between three factors (iron content, iron transporters, and iron sources) and *Salmonella* in poultry, some of which are discussed below.

The study of Shi et al. (2015) indicated that replacing FeSO₄ with Fe-Gly in equal Fe levels in poultry diets effectively improved blood biochemical parameters and antioxidative activity. Chelated sources of Fe have higher relative bioavailability compared to inorganic sources (Bovell-Benjamin et al., 2000; Feng et al., 2009; Kegley et al., 2002). Similarly, Sun et al. (2015) reported that Fe-Gly could alter the antioxidant status of broiler chickens and improve their growth performance and enhance their immune function. The DMT1 mRNA abundance in the chicken duodenum was decreased with an increase of Fe in the form of Fe-Gly in diets which indicates that Fe-Gly has a

higher bioavailability than FeSO₄ (Sun et al., 2015).

The DMT1 is a vital receptor which is responsible for transporting Fe across the apical membrane into the enterocyte (Zoller et al., 2002; Chua and Morgan, 1997). In a broiler chicken study, Jarosz et al. (2016) reported that the supplementation of chelated Fe could promote the response to developing inflammation by increasing the activity of T cytotoxic cells and the expression of IL-2. Kwiecien et al. (2015) reported that production performance and slaughter yield of broiler chickens are not affected when using low levels of Fe-Gly instead of FeSO₄. The coverage of 50% and 25% of the birds' requirement for this element with Fe-Gly increased the efficiency of fattening and blood biochemical parameters in broilers. These studies indicated that Fe-Gly could be effectively used by animals and can be supplemented to broiler diets at significantly lower levels than those recommended by Polish Feeding Standards for Poultry (2005; 80 mg/kg) or Aviagen (2013; 40 mg/kg). Studies have shown that excessive iron was detrimental to the production of T-helper and T cytotoxic cells, functionality of neutrophil, intracellular phagocytosis and the beneficial bacteria (Golding and Young, 1995; Kulkarni et al., 2011; Kuvibidila et al., 1999; Sherman, 1992). Studies on the effects of different iron sources and contents on the control of *Salmonella* infection in poultry still need to be conducted.

A study done by Balan and Babu (2017) showed a significant upregulation of transferrin in response to *Salmonella* infection and increased the persistence of *Salmonella* regardless of a significant expression of transferrin in macrophages. This study also reported that nitric oxide does not play a critical role against *Salmonella* infection. Other studies attributed increased survival of bacteria in the presence of transferrin to impair innate immune functions as measured by nitric oxide and the

expression of TNF- α (Nairz et al., 2007). Iron-regulated outer membrane proteins (IROMPs) are siderophore receptors expressed by *Salmonella*, which contribute to the virulence and survival of the bacteria *in vivo* (Clifton-Hadley et al., 2002). The expression of IROMPs are significant upregulated when the bacteria are faced with iron starvation. Kaneshige et al. (2009) investigated the efficacy of *IroN*, one of the IROMPs, against *Salmonella* Enteritidis and reported that intramuscular immunization of chickens with purified *IroN* led to excellent protection. This indicates that *IroN* has the potential to be developed as a vaccine component against *Salmonella*. In recent years, IROMPs are receiving more attention in the development of vaccines because of the unique immunogenic properties and strong antibody response (Chanana et al., 2006). There are two inactivated vaccines developed on the overexpression of IROMPs. One contains *Salmonella* Enteritidis, and the other contains a mixture of *Salmonella* Typhimurium (Zarate-Bonilla et al., 2014; Woodward et al., 2002). One of the key processes in developing an IROMPs-based vaccine is that microorganisms are cultured under iron-poor conditions (Clifton-Hadley et al., 2002). The two IROMPs-based vaccines have been tested and verified to be extremely immunogenic and protective against salmonellosis. Hence, they have been considered as effective strategies in the control of avian illness (Gast and Beard, 1993; Nakamura et al., 1994). Woodward et al. (2010) reported that the intramuscular inoculation of laying chickens with an iron-restricted *Salmonella* Enteritidis PT4 adjuvanted bacterin lead to protection against a *Salmonella* Enteritidis challenge. In addition, Noh et al. (2017) reported that guanosine 5' monophosphate-chelated calcium could improve the health of laying hens and egg quality when the birds are infected with *Salmonella* Gallinarum.

The National Research Council (NRC, 1994) has recommended an 80 mg Fe/kg diet for broilers. However, when high amounts of corn-soybean meal were supplemented, broiler diets had over 80 mg Fe/kg. Shinde et al. (2011) reported that iron sources and forms of Fe supplementation have no effect in performance, nutrient retention, and hematological indices of broiler chickens when the level of supplemented iron is 80 mg/kg. In cereals and oilseeds, the majority of iron is bound to phytates which reduce its availability for poultry (Taschetto et al., 2017; Yu et al., 2000). In order to reduce the amount of dietary supplementation of Fe in broiler chickens, Akter et al. (2017) investigated the effectiveness of phytase to increase Fe availability in diets containing high and low levels of Fe. The authors observed that high dietary Fe could inhibit phytase efficacy and subsequently reduced the overall performance and nutrient utilization in broiler chickens. Therefore, for optimum benefit from phytase supplementation, Fe levels should be kept under 100 mg/kg (Akter et al., 2017).

Taschetto et al. (2017) reported that adequate iron levels are beneficial to the health of hen, breeder egg production, iron content in the egg yolk, and hematological parameters of the hatching chick. However, in order to adequately provide iron in commercial feeds, feed ingredients should be carefully investigated prior to feed formulation to avoid unnecessary excesses of iron in the commercial production. The amount of iron needed for supplementation, therefore, will vary depending on the feed ingredient composition (Taschetto et al., 2017).

Generally speaking, poultry has enough iron incorporated into feeds because most natural feed ingredients contain a sufficient amount of iron. However, a very high concentration of iron in poultry diets (e.g. when using the wrong phosphate salt) can cause

gut pathogens to proliferate at an excessive rate and induce oxidative stress in broilers (Guo et al., 2018). Therefore, when formulating diets for poultry it is necessary to ensure iron is not added in excess. It is also critical to increase the bioavailability of iron by chickens and minimize the access to iron by *Salmonella*. Future studies in poultry are required to identify the mechanism by which pathogens use iron starvation to promote their growth and how this can be used to fight *Salmonella* infection in poultry. Moreover, the effect of *Salmonella* challenging the host iron metabolism in chickens needs to be determined.

Table 2.1. Fundamental regulatory proteins relating to iron in *Salmonella enterica*

Regulators	Functions	References
Fur	Uptake of ferric iron; invasion of epithelial cells; survival of <i>Salmonella</i> in macrophages	Leclerc et al., 2013
FNR	oxygen sensing, aerobic metabolism, NO detoxification, flagellar biosynthesis, virulence gene in SPI-1 including <i>mcpAC</i> , <i>cheV</i> , <i>srfABC</i>	Fink et al., 2007; Green et al., 1991
NorR	NO sensing, reduction and nitrogen metabolism; transcriptional activator for <i>norVW</i> operon	D'Autreaux et al., 2005
SoxR	Activator for <i>soxS</i> gene; superoxide sensing;	Hidalgo and Demple, 1994
IscR	biogenesis of Fe-S clusters; repressor of the <i>iscRSUA</i> operon	Schwartz et al., 2001
NsrR	Nitrosative stress resistance of <i>Salmonella</i> ; NO sensing; regulates <i>hmp</i> , <i>hliD</i> , <i>hcp-hcr</i> , <i>yeaR-yoaG</i> , <i>ygbA</i> and <i>ytfE</i>	Tucker et al., 2008; Karlinsey et al., 2012; Vergnes et al., 2017

Table 2.2 Endogenous siderophores of *Salmonella enterica*

Name	Types of siderophores	References
Enterobactin	Catechol	Fu, 1985
2,3,-dihydroxybenzoic acid	Catechol	Corbin and Bulen, 1969
2,3-dihydroxybenzoylserine	Catechol	O'brien and Gibson, 1970
Aerobactin	Hydroxamate	Haygood et al., 1993
Salmochelin S1	Catechol	Fu, 1985
Salmochelins S2	Catechol	Fu, 1985
Salmochelin S4	Catechol	Fu, 1985
Salmochelin SX	Catechol	Fu, 1985

Table 2.3 Exogenous siderophores of *Salmonella enterica*

Name	Source of siderophore	Types of siderophore	References
Myxochelins	<i>Myxobacteria</i>	Catechol	Kingsley et al., 1995
Amonabactin	<i>Aeromonas</i> spp	Catechol	Barghouthi et al., 1989; Kingsley et al., 1995
Desferrichrome	<i>Aspergillus, Ustilago, Penicillium</i>	Hydroxamate	Kingsley et al., 1995
Ferrichrosin	Fungi	Hydroxamate	Kingsley et al., 1995
Desferrioxamine B	<i>Streptomyces pylosus</i>	Hydroxamate	Gledhill and Buck, 2012; Kingsley et al., 1995
Desferrioxamine E	<i>Erwinia herbicola, Hafnia alvei</i>	Hydroxamate	Gledhill and Buck, 2012; Kingsley et al., 1995; Reissbrodt et al., 1990
Desferrioxamine G	<i>Hafnia alvei</i>	Hydroxamate	Kingsley et al., 1995; Reissbrodt et al., 1990; Gledhill and Buck, 2012
Coprogen	<i>Aspergillus nidulans, Ustilago maydis</i>	Hydroxamate	Kingsley et al., 1995; Philpott, 2006

Table 2.4 Iron requirement in different breeds of poultry (broiler, layer, quail)

Breed	Age of period (Days)	Responds Criteria	Iron requirement mg/kg	References
New Hampshire and Plymouth Rock	1 ~ 18	Growth, blood hemoglobin	75 ~80	Davis et al., 1968
New Hampshire × Columbian	8 ~ 22	Growth, blood hemoglobin, hematocrit	42	Southern and Baker., 1982
New Hampshire	0 ~ 28	Growth	75 ~ 80	Davis et al., 1968
Broiler strain	0 ~ 21	Growth, feed efficiency	56	Waddell and Sell., 1965
Rhode Island Red	0 ~ 56	Growth	40	Hill and Matrone., 1961

Arbor Acres	0 ~ 21	Expression of iron-containing enzymes in tissues	97 ~ 136	Ma et al., 2016
White Leghorn	N/A	Hatchability, hematocrit	45 ~ 55	Morck and Austic., 1981
White Leghorn	42 ~ 84	Hematocrit	35 ~ 45	Morck and Austic., 1980
Japanese Quail	0 ~ 28	Growth, blood hemoglobin, feathering	120	Harland et al., 1973
Cobb 500 broiler breeder hens	329 ~ 490	Hematocrit, hemoglobin; Fe content in total eggs, total hatching eggs and egg yolk	106	Taschetto et al., 2017

CHAPTER 3 HYPOTHESES AND OBJECTIVES

3.1 HYPOTHESES

Knowledge of mechanisms used by *Salmonella* to successfully infect poultry needs to be determined to develop successful mitigation strategies. The gut is the site where the infection is initiated. To reduce the risk of salmonellosis, prevention of *Salmonella* from colonization and invasion of the gut is essential. Therefore, the following hypotheses were tested in this thesis:

- 1) Iron chelators can inhibit the growth of wild-type and iron-uptake defective mutants (*tonB*, *iroN* *fepA*) of *Salmonella* in a range of environmental conditions;
- 2) The *tonB*, *iroN* *fepA* mutants of *Salmonella* can attenuate virulences on invading Caco-2 cells and infecting *Caenorhabditis elegans* (*C. elegans*).

3.2 OBJECTIVES

The overall objective was to evaluate the roles of iron uptake in the survival, colonization and virulence of *Salmonella* in animal guts using Caco-2 cells and *C. elegans* models. Specific objectives were to investigate:

- 1) The effects of different iron sources and concentrations on the *in-vitro* growth of wild-type and iron-uptake defective mutants of *Salmonella*;
- 2) The effects of different iron chelators on the *in-vitro* growth of wild-type and iron-uptake defective mutants of *Salmonella*;
- 3) The ability of wild-type and iron-uptake defective mutants of *Salmonella* to infect Caco-2 cells with the cell invasion assays;
- 4) The ability of wild-type and iron-uptake defective mutants of *Salmonella* to infect *C. elegans* (to death) with the life-span assays; and
- 5) The host responses of Caco-2 cells and *C. elegans* to the infection of wild-type and iron-uptake defective mutants of *Salmonella*.

CHAPTER 4 MANUSCRIPT

GROWTH AND VIRULENCE OF SALMONELLA TYPHIMURIUM DEFICIENT IN IRON-UPTAKE

4.1 ABSTRACT

The present study investigated the effects of iron, iron chelators, and mutations in *tonB* or *iroN fepA* on the growth and virulence of *Salmonella* Typhimurium. Results indicated that organic iron (ferric citrate and ferrous-L-ascorbate) supported better growth of *Salmonella* compared to inorganic iron. Among the tested chelators, 2,2'-bipyridyl at 500 μ M showed the highest inhibition to *Salmonella* growth with 5 μ M of ferrous sulfate. Deletion of genes (*tonB*⁻ and *iroN fepA*⁻) in the iron-uptake system attenuated *Salmonella* invasion of Caco-2 cells and its ability to damage the epithelial monolayer. The expression of all tested host genes in Caco-2 was not affected under the iron-poor condition. However, claudin 3, tight junction protein 1, tumor necrosis factor α , and interleukin-8 were altered under the iron-rich condition, depending on individual mutations. In *Caenorhabditis elegans*, a significant observation was the downregulation of ferritin 1 expression when the nematode was infected by the wild-type strain.

Keywords: *Caenorhabditis elegans*; Iron; Iron chelator; Iron-uptake; *Salmonella* Typhimurium; Virulence

4.2 INTRODUCTION

Non-typhi *Salmonella* (NTS) are invasive pathogens that cause non-typhoidal salmonellosis leading to significant public health issues and economic losses (Rabsch and Bäumler, 2001). In *Salmonella enterica* and other pathogens, the presence of iron

determines multiple pathogenic characters and is required for their full virulence (Frawley and Fang, 2014). The NTS possess a complicated iron-uptake system including the use of various siderophores in order to acquire enough iron from the environment (Andrews and Rodríguez-Quñones, 2003). Previous studies have shown that the iron-siderophore system of *Salmonella enterica* consists of the ferric-enterobactin (Fep) transporter system and ferrichrome-iron (Fhu) transporter system (Ferguson et al., 1998; Nagy et al., 2013). Importantly, the siderophore receptors of the two iron transporter systems are powered by TonB, an energy transduction protein that mediates the active transport of ferric-siderophores complex across the outer membrane of Gram-negative bacteria (Hannavy et al., 1990). Some outer membrane proteins of *Salmonella* Typhimurium not only function as catecholate siderophore receptors but also play a role in bacterial pathogenesis. Previous studies have shown that the virulence of an iron-uptake defective mutant (*iroN⁻fepA⁻cirA⁻*) was attenuated in a systemic infection in mice supplemented with L-norepinephrine (Williams et al., 2006). In addition, Tsolis et al. (1996) reported that the mutation in *tonB* attenuated the infection of *Salmonella* Typhimurium in mice by an intragastric route.

Massive and dynamic microbial communities including pathogens inhabit the animal gut. Epithelial cells are lined up and form mucosal surfaces that provide a barrier between hostile external environments and the internal milieu (Turner, 2009). Colonization or invasion of gastrointestinal mucosal surfaces is the first step for enteric pathogens to cause systematic infection (Giannasca et al., 1996). As an intracellular pathogen, *Salmonella* species possess the ability to infect a wide variety of cell types, from kidney epithelial cells to macrophages (Finlay and Falkow, 1990). Caco-2, a human colon carcinoma cell line that expresses and organizes brush border membrane components as

enterocytes, could mimic the differentiation of normal intestines under *in vitro* conditions (Neutra, 1989; Peterson and Mooseker, 1992). Well-differentiated Caco-2 cell monolayers could be adhered and invaded by *Salmonella* Typhimurium, providing a valuable *in vitro* model for pathogenic studies (Finlay and Falkow, 1990).

Caenorhabditis elegans has become a popular model for studying animal development and behavior as well as bacterium and host interactions (Wood et al., 1988; Labrousse et al., 2000). Labrousse et al. (2000) reported that *Salmonella* Typhimurium, a highly adapted strain with a narrow range of target hosts, was capable of infecting and causing the death of *C. elegans* (Jones et al., 1996). In addition, it has been reported that acid-sensitive mutants (*UK1*, *fur-1*, and *ompR*) of *Salmonella* Typhimurium presented a reduced virulence not only in mammals but also in *C. elegans* (Labrousse et al., 2000). The DAF/insulin-like growth factor (DAF/IGF), p38 mitogen-activated protein kinase (p38 MAPK) and transforming growth factor- β (TGF- β) signaling pathways that have remained essentially unchanged throughout evolution are critical components in immune defense mechanisms of *C. elegans* (Murphy et al., 2003; Zugasti et al., 2009). Zhou et al. (2018) recently described the host response of the nematode to *E. coli* infection and probiotic protection by activating the production of antimicrobial peptides through regulating its cell signaling, the p38 MAPK, and DAF/IGF pathways, in particular, to combat the bacterial infection.

In the present study, the strain of *Salmonella* Typhimurium from broiler chicken was used to understand the role of specific iron-uptake regulation genes in its pathogenesis, aiming for improving the effectiveness in *Salmonella* control for poultry production. Different iron-uptake defective strains of *Salmonella* and their complemented strains were

generated and compared. We examined four aspects: (1) the effect of different iron sources on *Salmonella* growth (both the WT and mutants); (2) the effect of iron chelators including EDTA, citric acid, and 2,2'-bipyridyl on inhibiting *Salmonella* growth; (3) the invasion of Caco-2 cells by *Salmonella* grown in the presence of different iron concentrations and the effect on their transepithelial electrical resistance, and their gene expression profile; (4) the ability of the *Salmonella* strains to infect *C. elegans* and the response of the nematode to the infection.

4.3 MATERIALS AND METHODS

4.3.1 Materials

Proteinase K was purchased from Qiagen (Germantown, Maryland, United States). Tryptic soy agar was purchased from BD Difco (Franklin Lakes, New Jersey, United States). All other chemical agents were purchased from Fisher Scientific (Ottawa, ON, Canada) and Sigma-Aldrich (Oakville, Ontario, Canada). Chemicals used in the present study were analytical reagent grade.

4.3.2 Iron content analysis using inductively coupled plasma optical emission spectrometry (ICP-OES)

Iscove's modified Dulbecco's medium (IMDM; Sigma-Aldrich) is a chemically defined iron-poor medium that is suitable for both tissue cultures and bacterial cultures. The iron concentration in the completed IMDM was determined using inductively coupled plasma optical emission spectrometry (ICP-OES). Briefly, the IMDM powder was dissolved in NERL™ high purity water (Fisher Scientific) and prepared according to the manufacturer's instructions. The medium samples containing 2% v/v nitric acid were analyzed by the Manitoba Chemical Analysis Laboratory for iron content using ICP-OES.

The results of ICP-OES analysis indicated that the iron concentration in the completed medium was approximately 0.8 μM . Although the form of iron in the IMDM medium is unknown, the contained iron level is negligible. Therefore, the IMDM medium with no iron supplementation is defined as an “iron-poor” medium, while the IMDM medium supplemented with an iron concentration at 5 μM or above is called an “iron-rich” medium.

4.3.3 Bacterial strains and growth conditions

Salmonella enterica serovar Typhimurium ABBSB1218-1 was isolated from broiler chicken as previously reported (Diarra et al., 2014). The strains used in this study including both the WT and mutants as well as some complemented strains are shown in Table 4.1 (Chekabab et al., 2019). The IMDM was used as the culture medium in the *in vitro* experiments to investigate the effect of iron and iron chelators on bacterial growth and virulence. Lysogeny broth (LB, Fisher Scientific) was used for bacterial culture in the *C. elegans* experiments. The WT and mutant strains were cultured aerobically with shaking at 37°C. Complemented strains were cultured and maintained under the same conditions as the WT strains, except for the supplementation of 50 ng/mL of kanamycin (Sigma-Aldrich) in the culture medium.

4.3.4 Evaluation of bacterial growth on different forms of iron

In order to determine the effect of different forms and different concentrations of iron on the growth of *Salmonella* Typhimurium, Bioscreen C MBR (Oy Growth Curves Ab Ltd, Helsinki, Vuorimiehenkatu, Finland) was used in this study to measure the optical density (OD) of bacterial suspension.

Salmonella Typhimurium was subcultured 3 times in IMDM to eliminate iron contamination from previous cultures. Bacteria were inoculated at 10^4 CFU/mL into

IMDM media containing 0 to 50 μM of either ferric citrate, ferric chloride, ferric EDTA, ferrous-L-ascorbate, or ferrous sulfate. The inoculated IMDM (350 μL /well) from each treatment was transferred to Bioscreen honeycomb plates (Oy Growth Curves Ab Ltd) with 5 wells of technical replicates, respectively. The optical density of the suspension in each well was measured every 15 minutes at 600 nm (OD_{600}) for 16 h. Growth curves were analyzed with Bioscreen C MBR software.

4.3.5 Evaluation of iron chelators for inhibiting bacterial growth

The growth of the WT of *Salmonella* Typhimurium was measured using Bioscreen C MBR (Oy Growth Curves Ab Ltd) and the protocol described above. Ferric chloride or ferrous sulfate were used as the iron source in this study. *Salmonella* growth in IMDM only served as a negative control, while the positive control was the growth in IMDM supplemented with 5 μM of ferric chloride or ferrous sulfate. Increasing concentrations of iron chelators, including EDTA (5 to 1000 μM), citric acid (1000 to 10000 μM), and 2,2'-bipyridyl (50 to 500 μM), were supplemented, respectively, to IMDM containing 5 μM of iron to examine the effect of the iron chelators on the growth of *Salmonella* Typhimurium.

4.3.6 Cell line and growth conditions

The colon adenocarcinoma cell line Caco-2 (ATCC HTB-37) was obtained from American Type Culture Collection (ATCC, Manassas, Virginia, United States). 6-well plates, 12-well plates, and 12-well millicell membrane cell inserts were purchased from Corning Costar (Fisher Scientific).

Caco-2 cells were cultured at 37°C under 5% CO_2 in Dulbecco's modified eagle medium (DMEM) with 4.5 g/L glucose, 0.586 g/L L-glutamine, penicillin-streptomycin 1000 U/mL (Fisher Scientific) and 3.7 g/L sodium bicarbonate (ATCC.org). The culture

medium was changed every other day and the antibiotic-free medium was applied at the last medium change before the experiments were performed. In the assay of *Salmonella* Typhimurium invasion into epithelial cells, Caco-2 cells were cultured in 12-well plates (Corning Costar, Fisher Scientific) with DMEM and 10% v/v FBS for 4 to 6 days to reach 100% cell confluency (5×10^4 cell/cm²). DMEM with 20% v/v FBS was used to cultivate the cells for the tight junction permeability assay.

4.3.7 Caco-2 invasion assay

The ability of *Salmonella* Typhimurium to invade epithelial cells was determined using Caco-2 cells at a multiplicity of infection (MOI) of 100:1 (Kortman et al., 2012). The DMEM medium was removed and Caco-2 monolayers were washed twice with 0.5 mL/well of phosphate-buffered saline (PBS) prior to the invasion assay. Bacterial strains were inoculated into fresh IMDM containing 5 μ M of ferric chloride at a final concentration of 4×10^7 CFU/mL. The bacterial suspension was transferred to the wells (0.5 mL/well) containing Caco-2 monolayers and co-incubated in IMDM at 37°C for 2 h. The bacterial cells were then killed by incubation with gentamicin (150 μ g/mL, 0.5 mL) in PBS for 1 h. Epithelial monolayers were then washed with PBS twice and lysed with 200 μ L of 0.1% (v/v) Triton X-100 (Sigma-Aldrich), the *Salmonella* count that had invaded Caco-2 cells was determined by 10-fold of serial dilution and plating on tryptic soy agar (BD Difco). The percentage of bacterial invasion was presented by the following formula:

$$\text{Invasion (\%)} = \frac{\text{bacterial count of 3 hours of co-incubation}}{\text{bacterial count of initial inoculation}} \times 100\%$$

4.3.8 Assay for Caco-2 tight junction permeability

The effect of the WT, mutants, and complements of *Salmonella* Typhimurium on the

tight junction permeability of epithelial cells was studied using Caco-2 cells. The Caco-2 cells were cultured in 12mm Millicell cell culture inserts (12 wells, Corning Costar, Fisher Scientific) in DMEM for 12 to 16 days till the transepithelial electrical resistance (TEER) value of the monolayers in all wells became stable between 1200 to 1400 Ohm (Ω) \times cm² prior to the assay for measuring TEER in IMDM after 2 washes of Caco-2 monolayers with PBS. The TEER was expressed after subtracting from the resistance reading of the supporting membrane and multiplying it by the surface area of the Caco-2 monolayer. The TEER value was measured every other day by Millicell ERS-2 Voltohmmeter (Millipore Co., Bedford, Massachusetts, United States). The MOI was 100:1 and *Salmonella* Typhimurium suspension was prepared as the invasion assay stated above. The bacterial suspension was added to the wells (500 μ L/well) containing Caco-2 monolayers and co-culture for 6 h in IMDM at 37°C under 5% CO₂. The TEER value of the monolayers was measured and recorded immediately 1 h after inoculation. The permeability value was calculated following the formula:

$$\text{Relative tight junction permeability at } x \text{ h} = \frac{\text{TEER value at } x \text{ h}}{\text{TEER value at } 0 \text{ h}} \times 100\% \quad (x = 0 \text{ to } 6)$$

4.3.9 *C. elegans* life-span assay

Caenorhabditis elegans (*C. elegans*) temperature-sensitive defect mutants (*glp-4*; SS104) and *Escherichia coli* OP50 were obtained from Caenorhabditis Genetics Center (Minneapolis, Minnesota, United States). *C. elegans* were maintained on nematode growth medium (NGM) with *E. coli* OP50 lawn using standard protocols (Eisenmann, 2005).

The *C. elegans* life-span assay with the treatment of various *Salmonella* Typhimurium strains was performed as described previously (Wang et al., 2011). Adult worms were

collected by sterilized water from NGM plates to perform synchronization as described by Stiernagle (2006). Approximately 300 synchronized eggs were transferred on NGM agar with *E. coli* OP50 lawn and incubated at 25°C for 72 h to grow to L4 stage. After the L4 stage, worms were collected in S basal solution and washed twice with S medium via centrifugation (1300 × g for 1 min) and resuspension, 20 to 25 worms were assigned to each well of a 6-well titer plate (Costar) with 2 mL of S medium and then incubated at 25°C for 8 days. The S medium was not changed during the assay. Each treatment had a total number of 45 to 50 worms. Worms fed with *E. coli* OP50 (10⁹ CFU/ml) served as the control, while worms treated with various *Salmonella* Typhimurium strains (10⁹ CFU/ml) were regarded as the treatment groups. The *E. coli* OP50 culture and *Salmonella* Typhimurium cultures used for the life-span assay were all in the early stationary phase. The bacteria were washed twice in S medium by centrifugation and resuspension before being fed to the nematode. In order to determine the survival of *C. elegans*, a worm was considered dead when it did not respond to touch. The number of dead worms was recorded daily and the percentage of worms' survival was presented following the formula:

$$\text{Survival (\%)} = \frac{\text{Total Worms} - \text{Dead Worms}}{\text{Total Worms}} \times 100\%$$

4.3.10 Total RNA extraction and cDNA synthesis

The method for extracting RNA from Caco-2 was adapted from Cuadras et al. (2002). Briefly, Caco-2 cells infected with bacteria were stabilized at 4°C overnight with *RNA*later solution (Ambion, Fisher Scientific). Total RNA of Caco-2 cells was isolated using the RNeasy mini kit (Qiagen) according to the manufacturer's instructions. The RNA quality and yield were determined using Nanodrop 1000 (Fisher Scientific) and 1.5% agarose gel

electrophoresis. Total RNA was purified using TURBO DNA-free™ kit (Ambion) according to the manufacturer's instructions. The cDNA synthesis was performed using qScript cDNA SuperMix (QuantaBio, Beverly, Massachusetts, USA). One microgram of purified RNA from each sample was used for cDNA synthesis in a 20 µL reaction mixture.

The method for total RNA isolation from *C. elegans* was adapted from Ketting et al. (2006). Briefly, a total of 40 worms from each treatment condition were collected on the 5th day of the life-span assay. The sampling on day 5 was chosen based on our observation that worm's survival decreased dramatically on day 6 and 7 post-infection with *Salmonella*. In each well, the worms were washed twice by RNase-free water to remove bacterial cells. The washed worms were transferred into a new RNase-free Eppendorf tube, mixed with 25 µL lysis buffer, and then incubated at 65°C for 10 min followed by 85°C for 1 min. The lysis buffer consisted of 0.5 % Triton (v/v), 0.5% Tween-20 (v/v), 0.25 µM EDTA, 2.5 µM Tris-HCl buffer (pH8.0), and 1 mg/mL of proteinase K. The total RNA of *C. elegans* was isolated from the lysate using TRIzol RNA isolation reagents (Fisher Scientific) according to manufacturer's instructions. The RNA yield and RNA integrity were measured and determined, respectively, by the same method described above for Caco-2 RNA isolation. The isolated total RNA was purified and cDNA was synthesized as previously described (Zhou et al., 2018).

4.3.11 Quantitative PCR analysis

The mRNA abundance of various genes related to tight junction proteins, inflammation factors, and nutrient transporters of Caco-2 cells was analyzed using quantitative polymerase chain reactions (qPCR) assays. The qPCR was performed with 50 ng of cDNA constructed above using the fluorescent dye SYBR Green methodology and an ABI Prism

7500 Fast Real-time PCR system (Applied Biosystems, Fisher Scientific). The qPCR conditions were: total of 40 PCR cycles, denaturing at 95°C for 30 s, annealing at 60°C for 1 min, extension at 72°C for 30 sec. The specificity of each gene amplification was verified at the end of each qPCR reaction by analysis of melting curves of the PCR products. The amplification curves were read with ABI Prism 7500 software using the comparative cycle thresh. Relative quantification of the target mRNA levels was presented after normalization of the total amount of cDNA tested to endogenous references, 18S RNA and glyceraldehyde 3-phosphate dehydrogenase (GAPDH). The primers for qPCR are listed in Table 4.2. The results of qPCR were analyzed using the $2^{-\Delta\Delta C_t}$ method to determine the fold changes of target genes (Zhou et al., 2018). The ΔC_t was presented as the difference in threshold cycle between the target genes and housekeeping genes (18S and GAPDH) and $\Delta\Delta C_t$ was the difference in ΔC_t between the *Salmonella*-infected Caco-2 cells and uninfected Caco-2 cells. The gene expression in the uninfected Caco-2 cells was used as the baseline (Reference = 1).

The mRNA abundance of several genes encoding for antimicrobial peptides and a defense molecule, components in the p38 MAPK and DAF/IGF signaling pathway, and nutrient utilization-related functions of *C. elegans* were analyzed by qPCR assays. 10 ng of *C. elegans* cDNA was used for a qPCR assay using the same conditions stated above. Relative quantification of the target mRNA levels was presented after normalization of endogenous references (*snb-1* and *act-1*). The primers for qPCR are listed in Table 4.3. The $2^{-\Delta\Delta C_t}$ method was used to determine the fold changes of target genes.¹⁹ The ΔC_t was presented as the difference in threshold cycle between the target genes and housekeeping genes (*act-1* and *snb*) and $\Delta\Delta C_t$ was the difference in ΔC_t between the *Salmonella*-

infected *C. elegans* and uninfected *C. elegans*. The gene expression in *C. elegans* treated with *E. coli* OP50 only (uninfected worms) was used as the baseline (Reference = 1).

4.3.12 Statistical analysis

All statistical analyses were performed by the GraphPad Prism 6 software (San Diego, United States) except the survival curve analyses of *C. elegans* were performed using the Statistical Analysis System (SAS release 9.4, SAS Institute Inc., Cary, NC, United States). Comparison of *C. elegans* survival curves were performed by Kaplan-Maier estimator with a log-rank test. In the bacterial invasion, tight junction permeability, and gene expression studies, Tukey's multiple comparison tests were used to determine differences among treatment means. $P < 0.05$ was taken to indicate statistical significance.

Table 4.1 Bacterial strains used in the thesis

Strains / Plasmids	Description and characteristics ^a	References
<u>Salmonella Typhimurium</u>		
ABBSB1218-1 WT	Wild-type isolated from Broil chicken.	Dhanani et al., 2015
ABBSB1218-1 <i>fepA</i> ⁻	Single deletion of FepA (Enterobactin transporter).	Chekabab et al., 2019
ABBSB1218-1 <i>iroN</i> ⁻	Single deletion of FepA (Catecholate transporter).	Chekabab et al., 2019
ABBSB1218-1 <i>tonB</i> ⁻	Single deletion of TonB (Energy transducer).	Chekabab et al., 2019
<i>tonB</i> ⁻ +pSCA-tonB	<i>tonB</i> ⁻ carrying plasmid pSCA-tonB	Chekabab et al., 2019
ABBSB1218-1 <i>iroN</i> ⁻ <i>fepA</i> ⁻	Double deletion of IroN and FepA.	Chekabab et al., 2019
<i>iroN</i> ⁻ <i>fepA</i> ⁻ +pSCA-fepA	<i>iroN</i> ⁻ <i>fepA</i> ⁻ carrying plasmid pSCA-fepA	Chekabab et al., 2019
<i>iroN</i> ⁻ <i>fepA</i> ⁻ + pSCA-iroN	<i>iroN</i> ⁻ <i>fepA</i> ⁻ carrying plasmid pSCA-iroN	Chekabab et al., 2019

Table 4.2 Primers of qPCR assay for Caco-2 cells

Genes	Sequence 5' – 3'	Product size (bp)	References
PepT1	FP: TTGGCCCAATGTCTCA	120	Datsenko and Wanner, 2000
	RP: GGCCCTGCTTGAAGTC		
CLDN3	FP: GGACTTCTACAACCCCGTGGT	230	Ding et al., 2017
	RP: AGACGTAGTCCTTGCGGTCGT		
TJP1	FP: CCTTCAGCTGTGGAA GAG GATG	287	Ding et al., 2017
	RP: AGCTCCACAGGCTTCAGGAAC		
IL-8	FP: AAGGAACCATCTCACTG	357	Crabtree et al., 1994
	RP: GATTCTTGGATAACCACAGAG		
TNF- α	FP: GCCATTGGCCAG GAG GGC	220	Saghizadeh et al., 1996
	RP: CGCCACCACGCT CTT CTG		
GAPDH	FP: GGAGTCCACTGGCGTCTTCAC	165	Piana et al., 2008
	RP: GAGGCATTGCTGATGATCTTGAGG		
18S	FP: CGCCGCTAGAGGTGAAATTC	62	Maubon et al., 2007
	RP: TTGGCAAATGCTTTCGCTC		

Note: TNF- α : Tumor necrosis factor α ; IL-8: Interleukin 8; PepT1: peptide transporter 1; CLDN3: Claudin 3; TJP1: Tight junction protein 1; GAPDH: Glyceraldehyde 3-phosphate dehydrogenase; 18S: 18S ribosomal RNA; bp: base pair; FP: forward primer; RP: reverse primer.

Table 4.3 Primers of qPCR assay for *C. elegans*

Genes	Sequence 5' – 3'	Product size (bp)	References
<i>sod-3</i>	FP: AAATGTCCGCCAGACTATG	124	Zhou et al., 2018
	RP: TGGCAAATCTCTCGCTGA		
<i>fgt-1</i>	FP: GGCCAGCTACTCAGCCATC	93	Feng et al., 2013
	RP: ATTTCCGGAGACGAAGAACCA		
<i>ftn-1</i>	FP: GACGTGTTGCCATGCAGAACATT	144	Kim et al., 2004
	RP: CATTGCGTTGTTCGGCGATT		
<i>spp-1</i>	FP: TGGACTATGCTGTTGCCGTT	106	Zhou et al., 2018
	RP: ACGCCTTGCTCTGGAGAATCC		
<i>clec-85</i>	FP: CCAATGGGATGACGGAACCA	121	Zhou et al., 2018
	RP: CTTCTGTCCAGCCAACGTCT		
<i>lys-7</i>	FP: GTACAGCGGTGGAGTCACTG	153	Zhou et al., 2018
	RP: GCCTTGAGCACATTTCCAGC		

<i>daf-16</i>	FP: TCGTCTCGTGTTTCTCCAGC RP: TAATCGGCTTCGACTCCTGC	181	Zhou et al., 2018
<i>pmk-1</i>	FP: CCAAAAATGACTCGCCGTGA RP: CTTTTGCAGTTGGACGACGA	115	Zhou et al., 2018
<i>nsy-1</i>	FP: AGCGGCTCGATCAACAAGAA RP: CCCATTCCACCGATATGCGA	122	Zhou et al., 2018
<i>act-1</i>	FP: CCCCACTCAATCCAAAGGCT RP: GTACGTCCGGAAGCGTAGAG	121	Zhou et al., 2018
<i>snb</i>	FP: CCGGATAAGACCATCTTGACG RP: GACGACTTCATCAACCTGAGC	128	Irazoqui et al., 2010

Note: *sod-3*: Superoxide dismutase 3; *fgt-1*: facilitated glucose transporter protein 1; *ftn-1*: Ferritin 1 ; *spp-1*: SaPosin-like Protein; *clcc-85*: C-type lectin; *lys-7*: Lysozyme-like protein 7; *daf-16*: Forkhead-type transcription factor; *pmk-1*: Mitogen-activated protein kinase *pmk-1*; *nsy-1*: Mitogen-activated protein kinase kinase kinase *nsy-1*; *act-1*: actin; *snb*: Synaptobrevin-1; bp: base pair; FP: forward primer; RP: reverse primer.

4.4 RESULTS

4.4.1 Effect of different iron forms on *Salmonella* growth

The effect of five different forms of iron including ferric chloride, ferrous sulfate, ferric EDTA, ferric citrate, and ferrous-L-ascorbate on the growth of *Salmonella* Typhimurium WT and its mutant strains were investigated. As shown in Figure 4.1, regardless of the forms of iron, the WT had much better growth than the two mutants (*tonB*⁻, *iroN*⁻ *fepA*⁻; $P < 0.05$) after 4 h incubation and the growth of the WT in IMDM only was slower than that in IMDM supplemented with 5 μM of iron ($P < 0.05$). The growth of the WT with ferrous-L-ascorbate or ferric citrate was improved compared to ferric EDTA or ferric chloride ($P < 0.05$). However, the WT treated with ferrous sulfate showed comparable growth ($P > 0.05$) with ferrous-L-ascorbate or ferric citrate. Both mutants hardly grew in IMDM only and had little growth when the medium was supplemented with 0.2 μM of iron regardless of the forms. No statistical analysis was therefore applied.

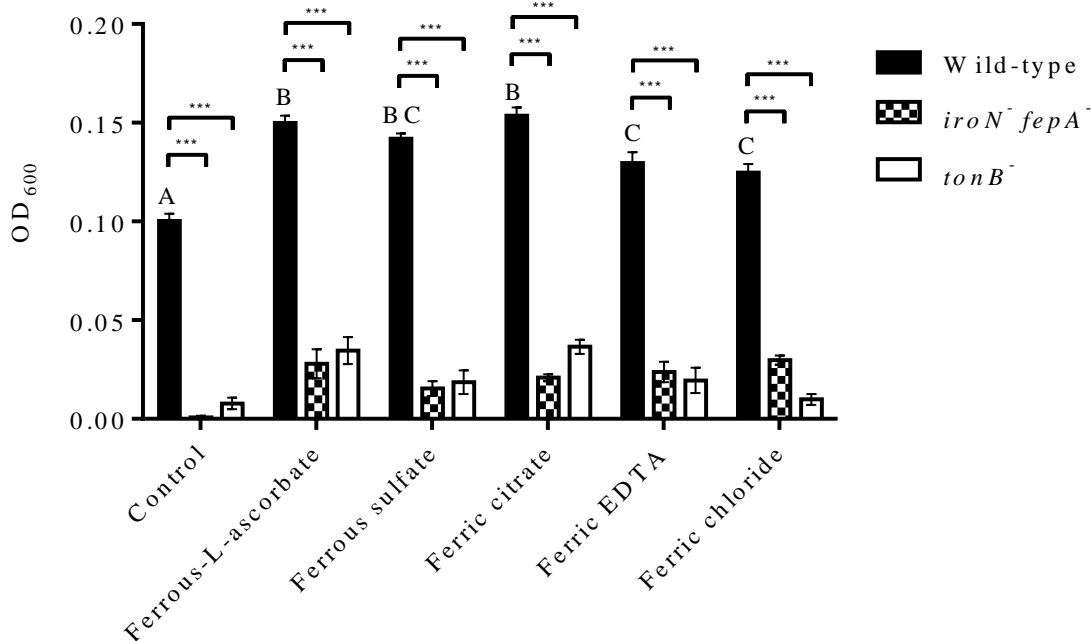

Figure 4.1 Effects of different iron forms on the growth of *Salmonella* Typhimurium. The optical density (OD₆₀₀) of bacterial suspension of the wild-type and iron-uptake defective mutants of *Salmonella* Typhimurium was measured after the strains were cultured in IMDM containing 0.2 μM of iron for 4 h. *ironN⁻ fepA⁻*: mutant defective in both *ironN* and *fepA*; *tonB⁻*: mutant defective in *tonB*; Values are means ± standard error of the mean (SEM), n = 5. Control: no iron added; EDTA: ethylenediaminetetraacetic acid. *** represents a significant difference between the wild-type and mutants within the control or each iron treatment, $P < 0.05$. Means marked with “A”, “B” and without a common letter were significantly different ($P < 0.05$) for the wild-type among different iron treatments.

4.4.2 Deletion of TonB, IroN and FepA on *Salmonella* growth

Figure 4.2 shows the growth of the WT, mutant *tonB*⁻, and mutant *iroN*⁻*fepA*⁻ in IMDM containing ferric chloride from 0 to 10 μM. The growth of the mutants was retarded compared to the WT. A concentration-dependent growth was observed when ferric chloride was increased from 0.1 μM to 10 μM. The growth curves of mutant *tonB*⁻, mutant *iroN*⁻*fepA*⁻, and the WT were comparable ($P > 0.05$) when the supplementation of ferric chloride exceeded 5 μM. The growth of the WT, mutant, and complementary strains on ferric chloride and ferric EDTA is shown in Figure 4.3. Both ferric chloride and ferric EDTA supported similar growth of all tested strains. Under the iron-poor condition, the WT appeared to grow approximately 100% and 30% better than mutant *tonB*⁻ and its complement ($P < 0.05$) respectively, but not under the iron-rich condition (Figure 4.3a,b). The growth of the WT, mutant *iroN*⁻*fepA*⁻, and its two partial complements were similar after 12 h incubation under the iron-poor condition (Figure 4.3c,d). The supplementation with 5 μM iron (iron-rich) generated full growth of the WT, mutant *iroN*⁻*fepA*⁻, and one of its partial complement except for the partial complement of *iroN*⁻*fepA*⁻ :: *iroN*⁺.

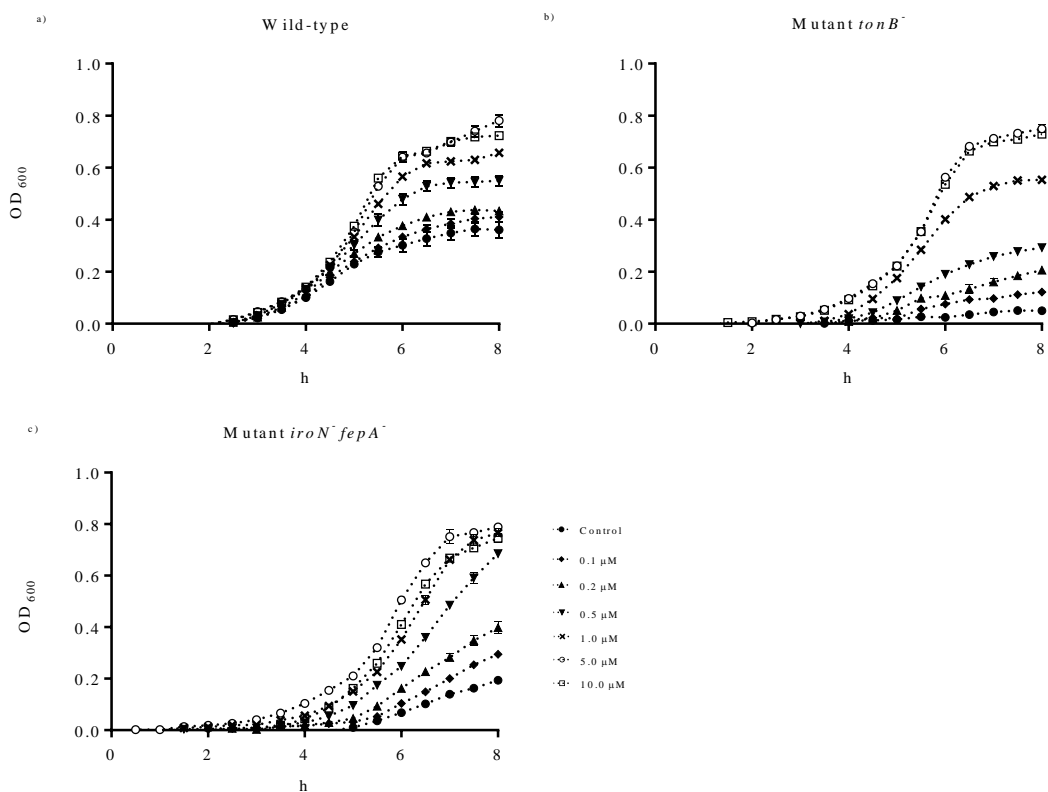

Figure 4.2 Effects of different concentrations of ferric chloride on the growth of *Salmonella Typhimurium*. **a)** The *in vitro* growth of the wild-type; **b)** the *in vitro* growth of mutant *tonB*⁻; **c)** the *in vitro* growth of mutant *iron*⁻ *fepA*⁻. The measurements were taken in 15 min intervals, for a total of 8 h. The concentrations of ferric chloride supplemented to the IMDM medium ranged from 0 to 10 μM. Values are means ± SEM, n = 5. Control: no iron added.

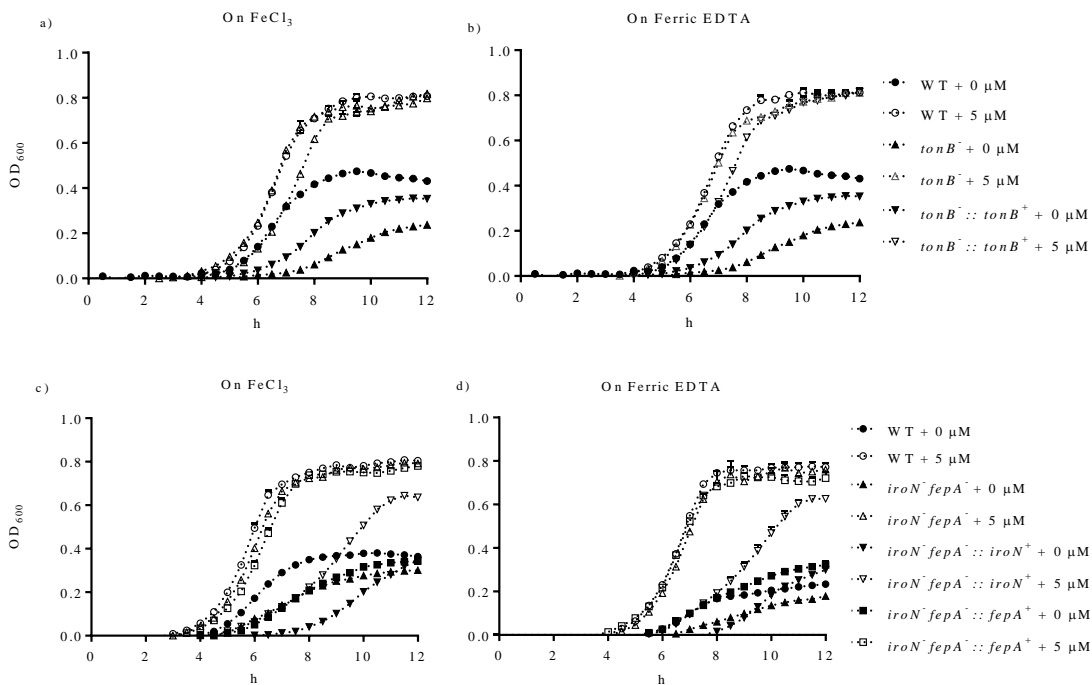

Figure 4.3 Comparison in the growth of the wild-type, mutant, and complementary strains of *Salmonella Typhimurium* on ferric chloride and ferric EDTA. *tonB*⁻: mutant defective in *tonB*; *tonB*⁻ :: *tonB*⁺: complement of mutant *tonB*⁻; *ironN*⁻ *fepA*⁻: mutant defective in both *ironN* and *fepA*; *ironN*⁻ *fepA*⁻ :: *ironN*⁺: partial complement of mutant *ironN*⁻ *fepA*⁻ with *ironN* only; *ironN*⁻ *fepA*⁻ :: *fepA*⁺: partial complement of mutant *ironN*⁻ *fepA*⁻ with *fepA* only. Panels **a** and **b**: mutant *tonB*⁻ and its complement cultured in the IMDM medium supplemented with ferric chloride and ferric EDTA, respectively. Panels **c** and **d**: mutant *ironN*⁻ *fepA*⁻ and its partial complements cultured in the IMDM medium supplemented with ferric chloride and ferric EDTA, respectively. The wild-type served as a control. The growth was evaluated in either iron-poor or iron-rich (5 μM) medium (IMDM). The measurements were taken in 15 min intervals, for a total of 12 h. Values are means ± SEM, n = 5.

4.4.2 Effect of iron chelators on the growth of *Salmonella*

The growth of the WT was monitored under the iron-rich condition with either ferric chloride or ferrous sulfate in the presence of increased concentrations of EDTA, citric acid, or 2,2'-bipyridyl. EDTA at 1 mM, showed significant inhibition of *Salmonella* growth ($P < 0.05$), reducing around 15% of growth (Figure 4.4). Similarly, citric acid reduced *Salmonella* growth ($P < 0.05$, approximately 50%) at 1 mM (Figure 4.5). In contrast, the growth of the pathogen was significantly inhibited (more than 50%) by 2,2'-bipyridyl at 250 μM ($P < 0.05$), and nearly abolished at 500 μM (Figure 4.6).

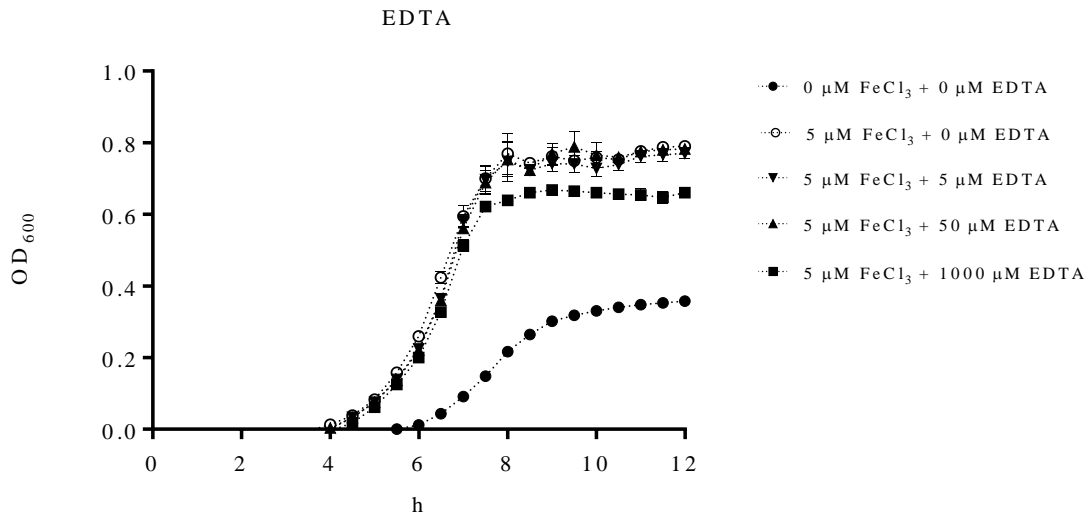

Figure 4.4 Effects of EDTA on the growth of *Salmonella Typhimurium* wild-type. The IMDM contained no or 5 μM of ferric chloride. *Salmonella* grew in the presence of EDTA (0 to 1000 μM). The measurements were taken in 15 min intervals, for a total of 8 h. Values are means ± SEM, n = 5.

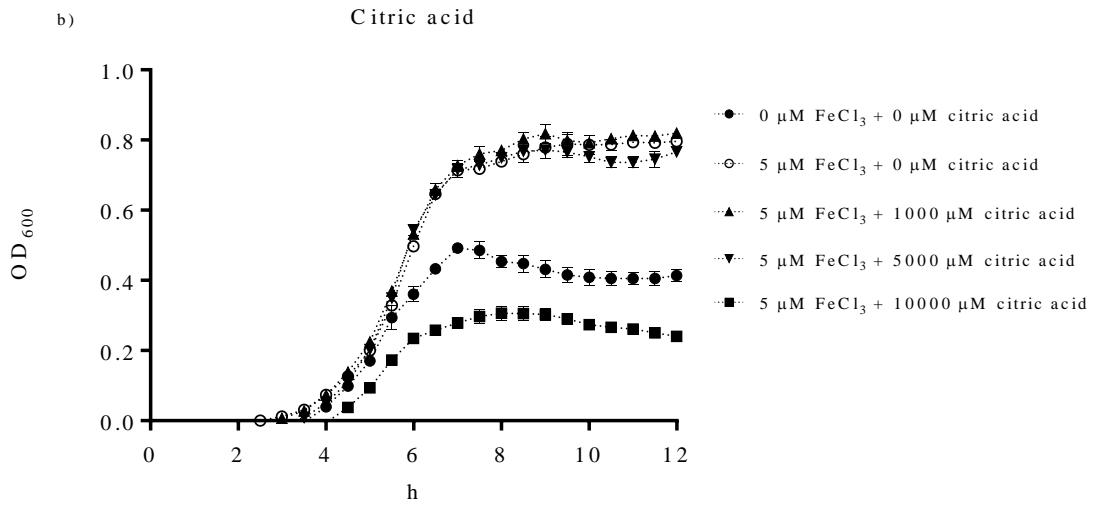

Figure 4.5 Effects of citric acid on the growth of *Salmonella Typhimurium* wild-type. The IMDM contained 0 or 5 μM of ferric chloride. *Salmonella* grew in the presence of citric acid (0 to 10000 μM). The measurements were taken in 15 min intervals, for a total of 8 h. Values are means ± SEM, n = 5.

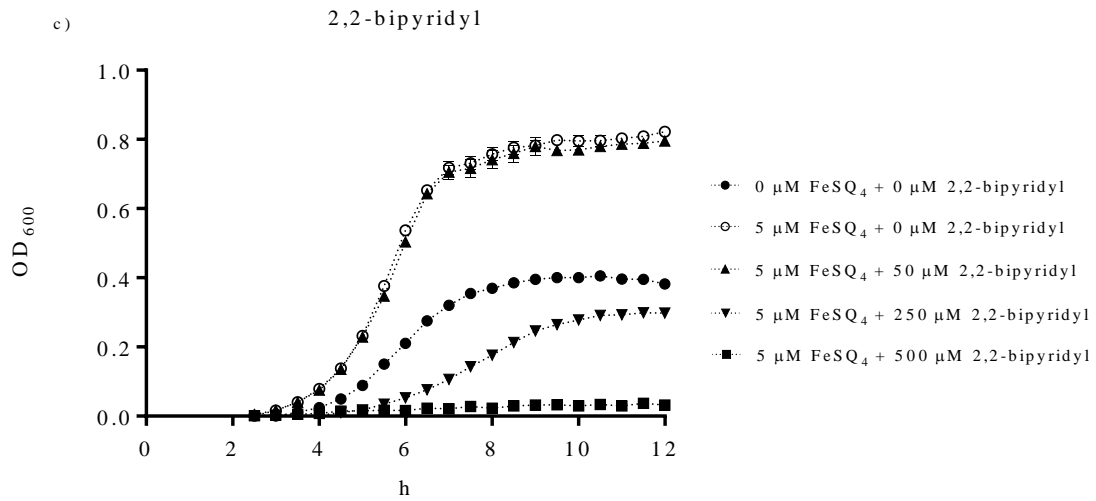

Figure 4.6 Effects of 2,2-bipyridyl on the growth of *Salmonella Typhimurium* wild-type. The IMDM contained 0 or 5 μM of ferrous sulfate. *Salmonella* grew in the presence of 2,2'-bipyridyl (0 to 250 μM). The measurements were taken in 15 min intervals, for a total of 8 h. Values are means ± SEM, n = 5.

4.4.3 Deletion of TonB, IroN and FepA on the invasion of Caco-2 cells

Caco-2 monolayers were used for the assay of *Salmonella* invasion into epithelial cells. As shown in Figure 4.7, the percentages of invasion of mutant *tonB*⁻ and mutant *iroN fepA*⁻ were significantly lower than that of the WT ($P < 0.05$) under both iron-rich and iron-poor conditions. The invasion ability of complement *tonB*⁻ :: *tonB*⁺ was fully restored under both conditions. The invasion ability of complement *iroN fepA*⁻ :: *fepA*⁺ was fully restored under both conditions, however, complement *iroN fepA*⁻ :: *iroN*⁺ was not. Only a partial recovery (approximately 78%) of the ability was observed when the complement was under iron-rich condition. The invasion ability of wild-type, *iroN fepA* and complementary strain of mutants were significantly improved ($P < 0.05$) under the iron-rich condition.

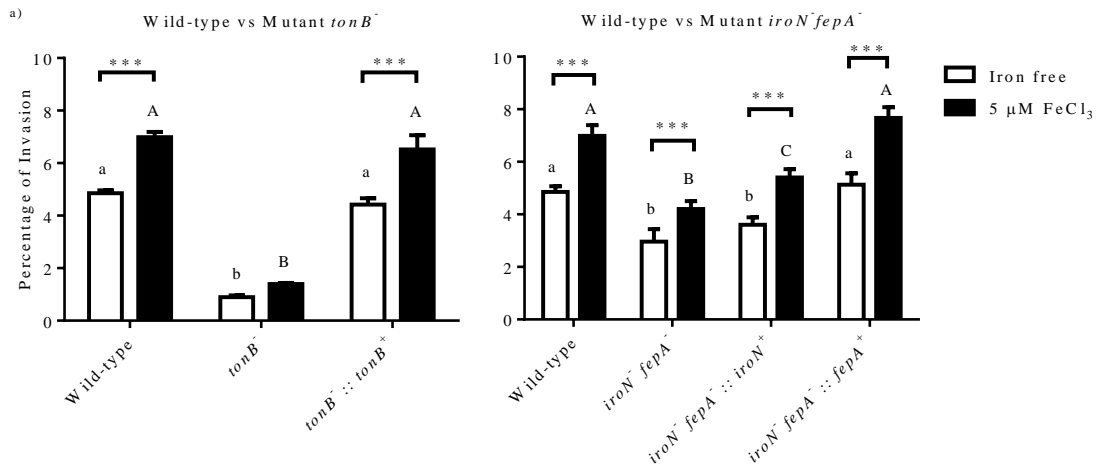

Figure 4.7 Effects of iron and iron-uptake mutation on *Salmonella* Typhimurium invasion into Caco-2 cells. *tonB*⁻: the mutant defective in *tonB*. *tonB*⁻ :: *tonB*⁺: the complemented *tonB*⁻ mutant. *ironN*⁻ *fepA*⁻: the mutant defective in *ironN* and *fepA*; *ironN*⁻ *fepA*⁻ :: *ironN*⁺: *ironN* partly complement of *ironN*⁻ *fepA*⁻; *ironN*⁻ *fepA*⁻ :: *fepA*⁺: *fepA* partly complement of *ironN*⁻ *fepA*⁻. Values are the percentage of invasion (mean ± SEM) of the pathogen into a monolayer of Caco-2 cells, n = 4. Percentage of the invasion was presented as the colony forming unit (CFU) of *Salmonella* that had invaded into Caco-2 cells divided by CFU of initial inoculation of *Salmonella*. Means marked with “a”, “b” and without a common letter were significantly different ($P \leq 0.05$) for the iron-poor condition among different strains; means marked with “A”, “B” and without a common letter were significantly different ($P \leq 0.05$) for the iron-supplemented condition among different strains. *** represents a significant difference between the iron-poor and iron-rich treatments within a strain, $P < 0.05$

4.4.4 Deletion of TonB, IronN and FepA on tight junction permeability of Caco-2 cells

All the treatment groups of Caco-2 monolayer shared a similar relative tight junction

permeability after the first 2 h of incubation with different *Salmonella* strains, including the WT, mutants *tonB*⁻ and *iron*⁻*fepA*⁻, and their complements (data not shown). As shown in Figure 4.8, the relative tight junction permeability of Caco-2 monolayer was significantly lower (10% reduction, $P < 0.05$) in the group treated with the WT compared with the control (uninfected group) after 3 h co-incubation. However, after 5 h co-incubation significant damage to the monolayer occurred (Figure 4.8). The WT showed the most severe damage to the monolayer among the different isolates. While both mutants caused less damage to the monolayer than the WT, the only complement of *tonB*⁻ (*tonB*⁻ :: *tonB*⁺) significantly restored the damage ($P < 0.05$). At the end of co-incubation (6th h), the Caco-2 monolayer in all the treatment groups except for the one treated with mutant *tonB*⁻ showed low relative TEER with no significant difference ($P > 0.05$, data not shown).

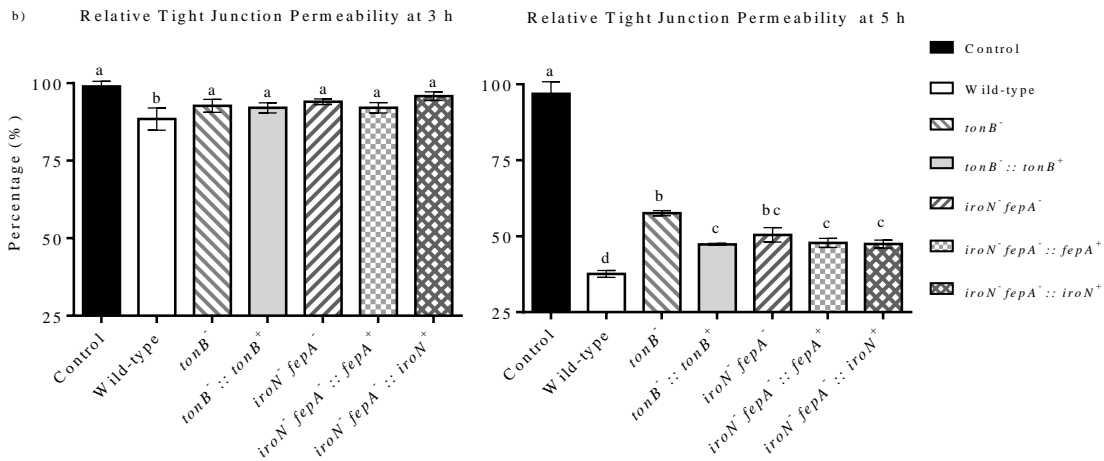

Figure 4.8 Effects of iron and iron-uptake mutation on the ability of *Salmonella* to damage epithelial monolayer of Caco-2 cells. *tonB*⁻: the mutant defective in *tonB*. *tonB*⁻ :: *tonB*⁺: the complemented *tonB*⁻ mutant. *iron*⁻ *fepA*⁻: the mutant defective in *iron* and *fepA*; *iron*⁻ *fepA*⁻ :: *iron*⁺: *iron* partly complement of *iron*⁻ *fepA*⁻; *iron*⁻ *fepA*⁻ :: *fepA*⁺: *fepA* partly complement of *iron*⁻ *fepA*⁻. Values are the percentage of relative tight junction permeability (mean ± SEM) that is presented by the measured transepithelial electrical resistance (TEER) values at 3 or 5 h of the assay divided by the initial TEER at the beginning (0 h), n = 4. Means without a common letter differ significantly ($P < 0.05$).

4.4.5 Host response of Caco-2 cells to *Salmonella* WT and its TonB, IroN and FepA mutants

Tight junction proteins (CLDN3, TJP1), nutrient transporter (PepT1) and pro-inflammatory cytokines (IL-8, TNF- α) were used as indicators to investigate the host response of Caco-2 cells to the *Salmonella* infection. As shown in Figure 4.9, the gene expression in Caco-2 cells showed no significant changes for all examined genes under the iron-poor condition between the infected and uninfected Caco-2, with the exception for IL-8 with WT treatment, as well as mutants (*tonB*⁻, *iroN*⁻ *fepA*⁻). Under the iron-rich condition, the transcription of both CLDN3 (5- to 9-fold changes) and TJP1 (3- to 4-fold changes) was downregulated significantly when Caco-2 was invaded by the WT and mutant *iroN*⁻ *fepA*⁻ ($P < 0.05$). Compared to mutant *tonB*⁻, the WT and mutant *iroN*⁻ *fepA*⁻ significantly downregulated the expression of CLDN3 (5- to 9-folds, $P < 0.05$) under the iron-rich condition (Figure 4.9a). A similar observation was also obtained with the expression of TJP1 (Figure 4.9b). Notably, mutant *tonB*⁻ slightly suppressed ($P > 0.05$) the gene expression of tight junction proteins regardless of iron-rich or iron-poor conditions. No significant difference ($P > 0.05$) in the gene expression of PepT1 was detected in Caco-2 cells treated with the WT and with the two mutants, respectively (Figure 4.9c), although the WT and mutant *iroN*⁻ *fepA*⁻ downregulated the gene expression significantly compared with uninfected Caco-2 cells (5 to 8 folds, $P < 0.05$). The gene expression of IL-8 and TNF- α is shown in Figure 4.9d and Figure 4.9e. All the strains significantly upregulated the expression level of TNF- α in the infected Caco-2 cells under the iron-rich condition compared with uninfected (more than 10 folds, $P < 0.05$). In addition, the upregulation was significantly higher in Caco-2 infected cells with the WT or mutant *iroN*⁻ *fepA*⁻ than with

mutant *tonB*⁻ (15 to 25 folds, $P < 0.05$). There was a significant upregulation (more than 10 folds, $P < 0.05$) in the expression of IL-8 when Caco-2 cells were infected with the WT or with mutant *iroN* *fepA*⁻ under the iron-rich condition. The increase was larger in the WT than in the mutant ($P < 0.05$). No significant difference was detected in the gene expression between the treatments of the two mutants ($P > 0.05$).

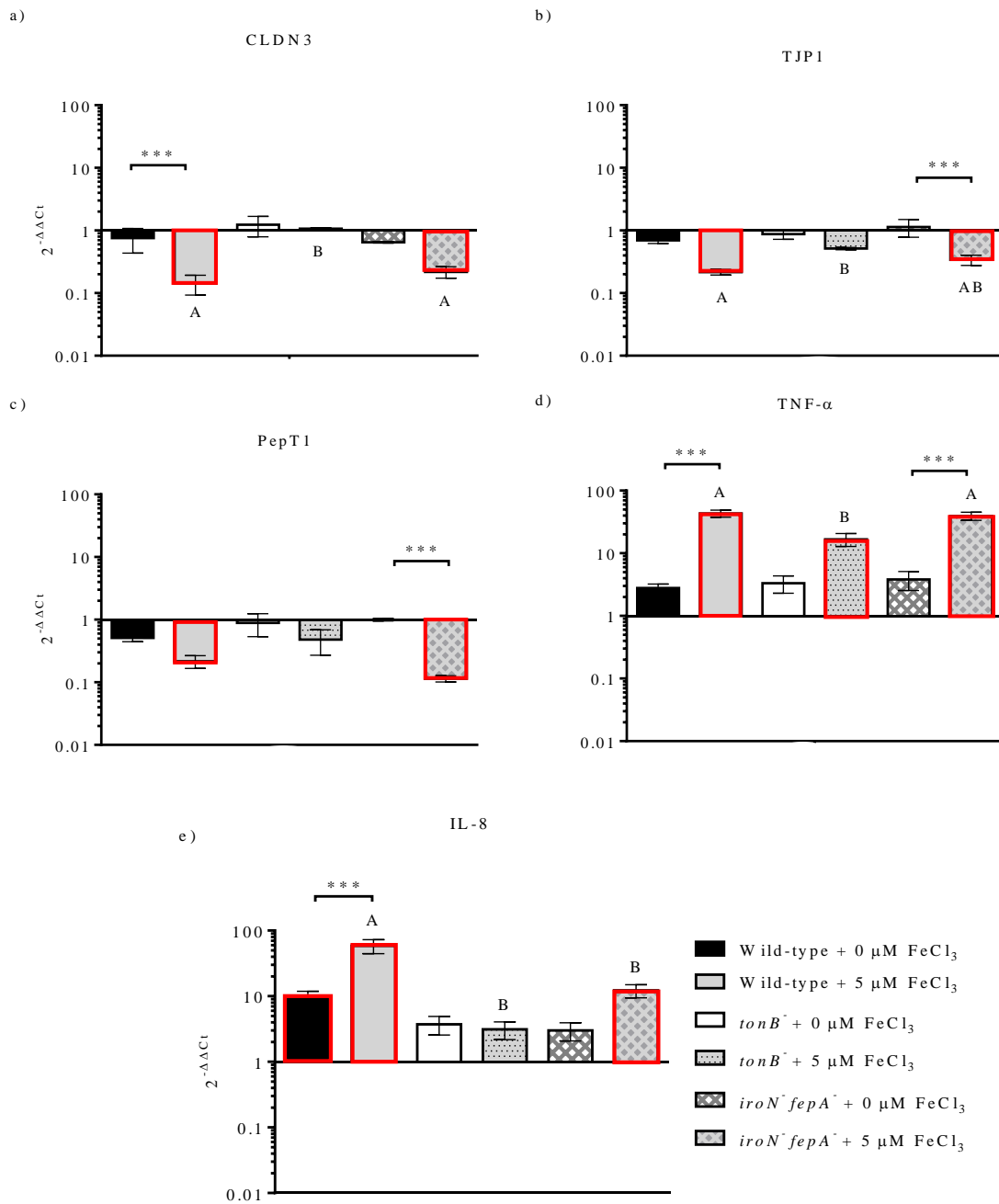

Figure 4.9 Gene expression of claudin 3 (CLDN3) (a), tight junction protein 1 (TJP1) (b), peptide transporter 1 (PepT1) (c), tumor necrosis factor alpha (TNF- α) (d), and interleukin 8 (IL-8) (e) in Caco-2 cells as the response to *Salmonella* invasion. The Caco-2 cells were

sampled during the 2nd hour of the assay of *Salmonella* invasion. The Caco-2 cells were sampled during the 2nd h of the invasion assay. Relative expression was determined using the $2^{-\Delta\Delta Ct}$ method. The ΔCt was presented as the comparison of the threshold cycle between the target genes and housekeeping genes (18S and GAPDH) and $\Delta\Delta Ct$ represented the comparison between the *Salmonella*-infected Caco-2 cells and uninfected Caco-2 cells. The reference (=1) for the comparison was the gene expression in uninfected Caco-2 cells. The RNA sample of each treatment had 3 biological replicates in the qPCR assay, n = 3. Bars with the red edge indicate a significant difference in the gene expression between infected and uninfected Caco-2 cells. *** represents a significant difference in the gene expression within a strain between the treatments of iron-poor and iron-rich ($P < 0.05$). Means marked with “A”, “B” and without a common letter were significantly different ($P < 0.05$) for the iron-rich treatment among different strains. *tonB*⁻: mutant defective in *tonB*; *iroN*⁻ *fepA*⁻: mutant defective in both *iroN* and *fepA*.

4.4.6 Deletion of TonB, IroN and FepA on the life-span of *C. elegans*

The survival curves of *C. elegans* after infection by the WT, mutants *tonB*⁻ and *iroN*⁻ *fepA*⁻, and their complements of *Salmonella* Typhimurium are shown in Figure 4.10. The death of worms was first observed on day 4 of the assay and viable worms were dramatically decreased in the following 4 days. The worms infected by the WT, mutant *iroN*⁻ *fepA*⁻, and its partial complements (*iroN*⁻ *fepA*⁻ :: *iroN*⁺ and *iroN*⁻ *fepA*⁻ :: *fepA*⁺) had a significantly reduced ($P < 0.05$) life-span compared to the nematode fed *E.coli* OP50 only (negative control). In contrast, there was no significant difference ($P > 0.05$) in life-span between the worms treated with mutant *tonB*⁻ and with *E. coli* OP50 only (uninfected). Complement *tonB*⁻ :: *tonB*⁺ restored the ability to cause a similar level of worm death by the WT ($P > 0.05$).

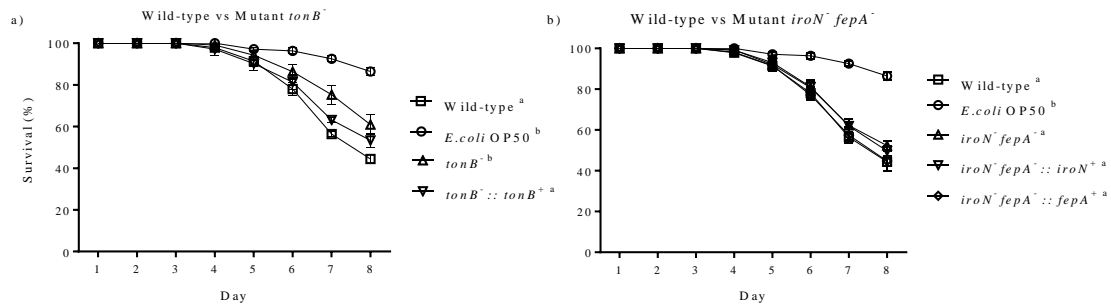

Figure 4.10 Effects of gene mutation in iron-uptake on the ability of *Salmonella* Typhimurium to infect *C. elegans*. **a)** the life-span of *C. elegans* treated with the wild-type, mutant *tonB*⁻, or the complement of *tonB*⁻; **b)** the life-span of *C. elegans* treated with the wild-type, mutant *ironN*⁻ *fepA*⁻, or partial complements of mutant *ironN*⁻ *fepA*⁻. Each treatment group had about 50 worms that were incubated in the S medium containing 24 μM iron in the lifespan assay. Worms fed with *E. coli* OP50 (10⁹ CFU/ml) only served as a reference. The final concentration of *Salmonella* in the assay mixture was 10⁹ CFU/ml. *tonB*⁻: mutant defective in *tonB*; *tonB*⁻ :: *tonB*⁺: complement of mutant *tonB*⁻; *ironN*⁻ *fepA*⁻: mutant defective in both *ironN* and *fepA*; *ironN*⁻ *fepA*⁻ :: *ironN*⁺: partial complement of mutant *ironN*⁻ *fepA*⁻ with *ironN* only; *ironN*⁻ *fepA*⁻ :: *fepA*⁺: partial complement of mutant *ironN*⁻ *fepA*⁻ with *fepA* only. Survival curves without a common letter differ significantly ($P < 0.05$). The *E. coli* OP50 and *Salmonella* cultures used for the *C. elegans* life-span assay were all in the early stationary phase.

4.4.7 Host response of *C. elegans* to *Salmonella* WT and its TonB, IroN and FepA mutants

The worms sampled on day 5 in the lifespan assay, where iron was not limited, were used to investigate the gene expression of defense molecule (*sod-3*), antimicrobial peptides (*spp-1*, *clec-85*, *lys-7*), nutrient transporter (*fgt-1*), iron storage (*ftn-1*), and components in IGF (*daf-16*) or p38 MAPK signaling pathway (*nsy-1*, *pmk-1*). The treatment groups of nematodes were infected with the WT and mutants (*tonB⁻*, *iroN⁻ fepA⁻*), respectively. As shown in Figure 4.11, no significant difference ($P > 0.05$) was detected in the expression of all tested genes except for *ftn-1* that was downregulated (5 folds, $P < 0.05$) in the worms infected with WT compared to the uninfected worms. In contrast, more than a 2-fold increase in the gene expression of *clec-85*, *daf-16*, and *sod-3* ($P < 0.05$) was achieved by mutant *tonB⁻* ($P < 0.05$). Mutant *iroN⁻ fepA⁻* also demonstrated a similar upregulation ($P < 0.05$), including genes *spp-1*, *nsy-1*, *pmk-1*, *daf-16*, and *sod-3*. Compared with the WT, the two mutants enhanced the expression (4 to 7 folds, $P < 0.05$) of five genes in total (*clec-85*, *nsy-1*, *pmk-1*, *daf-16*, and *sod-3*), in which mutant *tonB⁻* altered *clec-85*, *daf-16*, and *sod-3* and mutant *iroN⁻ fepA⁻* upregulated *nsy-1*, *pmk-1*, *daf-16*. The *ftn-1* was the only gene in the worms treated with the WT that was significantly downregulated compared to the mutant-treated and uninfected worms ($P < 0.05$).

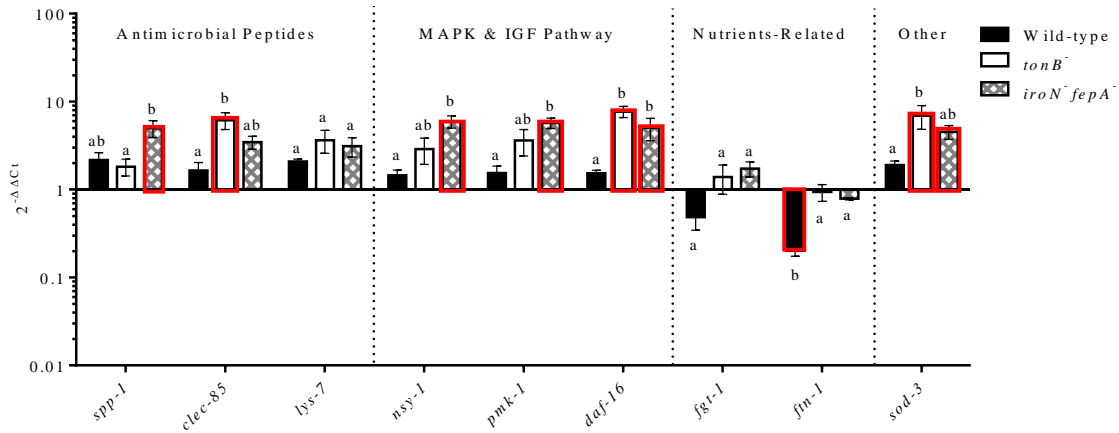

Figure 4.11 Host response of *C. elegans* at gene expression level to the infection of *Salmonella* Typhimurium wild-type and mutants. Several genes relating to antimicrobial peptide production, MAPK & IGF signaling pathways, and other molecules relating to nutrient metabolism and defense in *C. elegans* were selected as the targets for the qPCR assay. The nematode was sampled on day 5 of the lifespan assay. Relative expression was determined using the $2^{-\Delta\Delta Ct}$ method. The ΔCt was the comparison in the threshold cycle between target genes and housekeeping genes (*snb* and *act-1*). The $\Delta\Delta Ct$ represented the comparison between *Salmonella*-infected *C. elegans* and *C. elegans* treated with *E. coli* OP50 only. The reference (=1) for the comparison was the gene expression in uninfected *C. elegans*. The RNA samples of each treatment had 3 biological replicates in the qPCR assay, n = 3. Means marked with “a”, “b” and without a common letter were significantly different ($P < 0.05$) for the same gene among different strains. Bars with the red edge indicate a significant difference in the gene expression between infected and uninfected Caco-2 cells. *tonB*⁻: mutant defective in *tonB*; *iron*⁻ *fepA*⁻: mutant defective in both *iron* and *fepA*; *sod-3*: superoxide dismutase 3; *fgt-1*: facilitated glucose transporter protein 1; *ftn-1*: ferritin; *spp-1*: saPosin-like protein; *clec-85*: c-type lectin; *lys-7*: lysozyme-like

protein 7; *daf-16*: forkhead-type transcription factor; *pmk-1*: mitogen-activated protein kinase pmk-1; *nsy-1*: mitogen-activated protein kinase kinase kinase nsy-1; IGF: insulin-like growth factor; MAPK: mitogen-activated protein kinases.

4.5 DISCUSSION

Salmonella Typhimurium strains used in the present study were isolated from broiler chicken (Dhanani et al., 2015). The information generated from this study may be useful for developing a strategy to control pathogen infection during poultry production.

One objective of the present study was to investigate the effect of different forms of iron on the growth of *Salmonella* Typhimurium. Organic iron (ferrous-L-ascorbate, ferric citrate) appeared to be favored by the pathogen for growth compared with inorganic iron (ferric EDTA, ferric chloride), as *Salmonella* growth on organic iron took less time to reach the stationary phase than on inorganic iron (data not shown). A similar preference to organic iron for iron absorption has been reported previously in animals. Some studies proposed that animals had a high level organic iron absorption because organic acid and amino acid ligands of the organic iron can protect the ferrous iron from oxidation and/or interaction with other metal ions (Jia et al., 2015; Teucher et al., 2004). Another study confirmed that intestinal epithelial cells favored ferrous iron over ferric iron because the DMT1 was the major pathway for uptake of ferrous iron in both organic and inorganic form (Yeung et al., 2005). Even though *Salmonella* had an Iron-Porin-Feo (Feo) system that is similar to the DMT1 pathway of mammalian animal, a complicate iron-siderophore system is also used by *Salmonella* to acquire iron to grow and survive in iron-poor environments (Chu et al., 2010; Lau et al., 2015). Moreover, enteric bacteria including *Salmonella* possess both a citrate-dependent iron (III) transport and ferric dicitrate transport systems for uptaking ferric-citrate as well as a wide variety of metal-free and metal-loaded tricarboxylic acids (Banerjee et al., 2016; Pressler et al., 1988). An exclusive citrate-dependent iron transport system for uptaking ferric-citrate may explain why ferric-citrate showed a better

enhancement on *Salmonella* growth compared with the inorganic iron investigated (FeSQ₄ and FeCl₃) (Angerer et al., 1998).

In the present study, the function of IroN and FepA on the growth of *Salmonella* was evaluated. Results confirmed previous reports that TonB, FepA, and IroN proteins are important for *Salmonella* growth (Rabsch et al., 1999; Mademidis et al., 1998). Mutation of *tonB* impaired the functionality of all *tonB*-dependent (iron-siderophores) receptors on the outer membrane as shown by growth curves. Similarly, mutation of *iroN* and *fepA* impaired the integrity and functionality of the Fep system, which retarded the growth of mutant *iroN⁻fepA⁻*. Interestingly, the growth curves of all mutant strains were similar to the WT under the iron-rich condition (> 5 μM), which suggested that *Salmonella* might have an Fe³⁺ uptake system that did not relate to TonB protein nor to the investigated iron-siderophore system.

Among the three chelators tested in the present study, 2,2'-bipyridyl was the most effective in inhibiting *Salmonella* growth. Previous studies have reported that 2,2'-bipyridyl could increase the antimicrobial property of polymer-Cu (II) complexes by enhancing the lipophilic character of the central metal atom (Chandraleka et al., 2014; Kumar et al., 2008). However, most of the antimicrobial activities of 2,2'-bipyridyl were reported when it was combined with other metal ions (e.g. platinum, cobalt, and copper) or with metal complexes (Srinivasan et al., 2005; Egan et al., 2004). It is possible that 2,2'-bipyridyl chelated Fe³⁺ and/or other metal ions supplemented in media, which retarded the growth of *Salmonella*. Unfortunately, a toxicity test on rat showed that the LD₅₀ of 2,2'-bipyridyl was 256 mg/kg and 155 mg/kg through oral administration and vein injection, respectively (Bodavari et al., 2006). More studies are therefore required to determine its

potential in application.

Our results clearly confirmed with previous studies, that iron increased the ability of *Salmonella* Typhimurium to invade a differentiated Caco-2 monolayer (Altier et al., 2005; Cossart et al., 2004). Moreover, iron-uptake systems (Fep) defective mutants of *Salmonella* Typhimurium significantly reduced their ability to invade the intestinal epithelial cells, suggesting that iron-uptake systems are required for the virulence of *Salmonella* in animal guts. This is also confirmed by the evidence that defective iron-uptake systems prevented an increase in permeability through tight junction stabilization (e.g. CLDN3) and blocking of proinflammatory response (e.g. reduced TNF- α and IL-8 gene expression. It is possible that upon the downregulation of the elevated expression of the TNF- α and IL-8 by defective iron-uptake systems (Fep), the expression of CLDN3 was stabilized; as a result, damage to the integrity of the enterocyte barrier was slowed down. A similar correlation was reported previously in the porcine jejunal epithelial IPEC-J2 cell line (Coburn et al., 2007). In addition, IL-8 has been shown essential for *Salmonella* to pass through epithelial Caco-2 monolayers and TNF- α contributes to the tissue pathology associated with *Salmonella* infection (Karimi et al., 2018; Arnold et al., 1993). Interestingly, the downregulation of the PepT1 expression by *Salmonella* Typhimurium under the iron-rich condition was prevented by the mutant *tonB*⁻, suggesting *Salmonella* infection could reduce nutrient absorption (e.g. small peptides). We also demonstrated that iron was required for observing the changes in the gene expression of tight junction protein and proinflammatory cytokines among the WT and iron-uptake systems defective mutants of *Salmonella* Typhimurium. Taken together, our results suggest that iron and iron-uptake systems are essential for the virulence of *Salmonella* in animal guts.

In the present study, the importance of TonB, IroN and FepA in the virulence of *Salmonella* was evaluated in *C. elegans* with a life-span assay followed by an investigation into the host gene expression and regulation of cell signaling and defense molecule production. The result of the lifespan assay (except for mutant *iroN⁻fepA⁻*) was consistent with the observation from the Caco-2 invasion experiment in the present study (Figure 4.7) as well as from mouse infection studies reported previously (Tsolis et al., 2008; Rabsch et al., 2003). It is interesting to note that the WT strain of *Salmonella* Typhimurium caused no changes in the expression of all tested genes relating to cell signaling and defense molecule production (including antimicrobial peptides) in the infected nematode compared with uninfected worms (Figure 4.11). In contrast, either mutant *tonB⁻* or mutant *iroN⁻fepA⁻* was able to upregulate some of the genes, e.g. *clec-85*, *sod-3*, and *daf-16* by mutant *tonB⁻* and *spp-1*, *sod-3*, *nsy-1*, *pmk-1*, and *daf-16* by mutant *iroN⁻fepA⁻*, suggesting the involvement of both genes in *Salmonella* infection to *C. elegans*. Given the facts that only mutant *tonB⁻* (but not mutant *iroN⁻fepA⁻*) lost the ability to infect *C. elegans* and its complement restored the capacity in addition to the upregulation of *clec-85* and *sod-3* expression by the mutant in particular, it appears that both *clec-85* and *sod-3* may play a substantial role in the defense of the nematode against *Salmonella* infection. It has been documented from previous studies that the p38 MAPK and DAF/IGF pathways control the expression of the antimicrobial peptides (Alper et al., 2007; Kamaladevi et al., 2016). Very recently, there was a report that a *Lactobacillus* isolate could regulate *C. elegans* signaling through the p38 MAPK and DAF/IGF pathways to control the production of antimicrobial peptides and defense molecules to combat *E. coli* infection (Zhou et al., 2018). One significant finding from the *C. elegans* experiment in the present study was the

downregulation of *ftn-1* by the WT of *Salmonella* Typhimurium only (Figure 4.11). The gene regulates the expression of ferritin 1 that has a role in iron storage of the host and knocking out of *ftn-1* would reduce the life-span of *C. elegans* grown in the environment with excess iron (Kim et al., 2004). It may suggest that *Salmonella* could affect the expression of *ftn-1* and create an intracellular environment with sufficient iron. Our observation on the inability of mutants *tonB*⁻ and *iroN* *fepA*⁻ to alter the gene expression of *ftn-1* supports the notion, providing further evidence for the importance of *ftn-1* in the pathogen and host interaction during *Salmonella* infection.

4.6 CONCLUSION

In conclusion, the present study has determined: (1) organic iron (ferric citrate and ferrous-L-ascorbate) supported better growth of *Salmonella* compared to inorganic iron; (2) 2,2'-bipyridyl had potential in controlling *Salmonella* growth under the iron-rich condition; (3) mutation in *tonB* and double mutations in *iroN*, *fepA* could lessen the ability of *Salmonella* to invade Caco-2 cells and damage the epithelial monolayer; (4) supplementation of iron could affect the expression of tight junction proteins, peptide transporter, and proinflammatory cytokines in Caco-2 cells during *Salmonella* infection; (5) mutation in *tonB* reduced the infection of *Salmonella* Typhimurium to *C. elegans* and the expression of *ftn-1* was downregulated when the nematode was infected by the WT strain only.

CHAPTER 5 GENERAL DISCUSSION AND CONCLUSION

5.1 GENERAL DISCUSSION

Salmonella enterica is a notorious enteric pathogen that has a wide range of animal hosts, causing enormous agricultural losses and medical burden around the world (Eng et al., 2015). *Salmonella* is most frequently found in poultry, eggs, milk and other agricultural products such as fruits and vegetables (Pui et al. 2011; Silva et al. 2011). The emergence of *Salmonella* has raised the attention of the public as it becomes more virulent, causing an increase in the mortality of infected animals and humans (Chiu et al. 2002). Understanding *Salmonella* survival mechanisms in production systems and foods derived from them is key to the development of successful strategies to lessen the attendant risk. Antibiotics have widely been used in the poultry industry to fight pathogens infection (e.g. *Salmonella*) and to stimulate growth performance (Omonijo et al., 2018). Total global consumption of antibiotics in animal production was estimated at 63,151 tons in 2010 with an increasing trend (Van Boeckel et al., 2015). Scientific evidence suggests that this practice may lead to the spread of antimicrobial-resistant bacterial pathogens in both poultry and humans, leading to public health problems (Yang et al., 2015; Hassan et al., 2018). Therefore, both consumers and governments are keen for the poultry industry to move towards antibiotic-free production. Therefore, new technologies are needed to control *Salmonella* infection. Along with organic acids, enzymes, probiotics, antimicrobial peptides, medium chain fatty acids and essential oils (Omonijo et al., 2018), reducing iron availability to *Salmonella* could be a promising approach to control *Salmonella* infection in poultry because non-typhoidal *Salmonella enterica* serovars are well equipped to acquire iron for their survival to cause disease in their hosts (Frawley et al. 2014). Therefore, the aim of this study was to

evaluate the roles of iron uptake in the survival, colonization and virulence of *Salmonella* in animal guts.

Knowledge of mechanisms used by *Salmonella* to successfully infect poultry needs to be determined to develop successful mitigation strategies. The gut is the site where the *Salmonella* infection is initiated. It is essential to prevent *Salmonella* colonization and invasion in the gut to reduce the risk of salmonellosis. The intestinal epithelium is a monolayer that constitutes the biggest and most critical barrier against the environment of the intestine lumen. It acts as a selectively permeable barrier, enabling the absorption of nutrients, electrolytes, and water while protecting the animal from toxins, antigens, and enteric flora. Therefore, it is very important to select proper models to study how iron and iron uptake systems affect the survival, colonization and virulence of *Salmonella* in the gut. *Caenorhabditis elegans* is a small free-living soil nematode that has been extensively used as an experimental *in vivo* system for biological studies because of its small size, short generation time and suitability for genetic analysis. In particular, *C. elegans* has been used to study pathogen and host interactions of various bacterial pathogens including *Salmonella*, in addition to its increased use for screening antimicrobials, such as probiotic bacteria for *Salmonella* control (Leung et al. 2008). Using the nematode infection model by measuring its life-span, several probiotic candidates have been identified for *Salmonella* control and revealed a part of molecular mechanisms underlying the protection offered by the probiotic isolates (Yang et al., 2014; Zhou et al., 2014). This model system provides a useful tool to study the survival and control of *Salmonella* in the gut. In this study, this *C. elegans* model was used to investigate the ability of wild-type and iron-uptake defective mutants of *Salmonella* to infect *C. elegans* (to death) with the life-span assays and the gene expression

of *C. elegans* to *Salmonella* infection. Moreover, Caco-2 cells that have been extensively used over the last thirty years as a model of the intestinal barrier (Sambuy et al. 2005), were used to determine the ability of wild-type and iron-uptake defective mutants of *Salmonella* to infect a host with the invasion assays. Results from these two models clearly indicate that iron uptake systems and iron are required for the survival, colonization, virulence of *Salmonella* in animal guts. These findings will help us to identify which iron-uptake protein is most essential for *Salmonella* virulence and then to develop methods targeting the specific iron-uptake protein to reduce iron availability for *Salmonella*.

Given that there may be some differences between chicken enterocytes and Caco-2 cells, it is worth using chicken enterocytes in invasion assays. However, chicken enterocytes are not currently commercially available. Primary chicken enterocytes might be used to screen different factors and their interactions with microbiome, and potentially be used to in the development of intervention strategies for *Salmonella* (e.g. iron chelators) (Rath et al., 2018). Alternatively, the ligated poultry intestines could have been used in the present study because they have been used to not only measure the absorption of nutrients (e.g. iron) (Zhang et al., 2016; 2017; 2018) but also to study the virulence of *Clostridium perfringens* isolates recovered from antibiotic-free chicken flocks (Parent et al., 2017). Eventually *in vivo* poultry trials are needed to investigate the efficacy of iron based on strategies against the survival, colonization and virulence of *Salmonella*.

This study clearly demonstrated that EDTA, 2,2-bipyridyl and citric acid can effectively inhibit the growth of wild-type and iron-uptake defective mutants of *Salmonella*. 2,2-bipyridyl is not approved as a feed ingredient. Citric acid and EDTA can be used in animal feeds, but these chelators not only reduce iron availability to *Salmonella* but also

decrease the bioavailability of minerals including iron to animal hosts. This makes it very difficult to include chelators into feeds to control *Salmonella*. However, these chelators could be included in poultry litters to reduce the survival of *Salmonella* in poultry farms.

For iron supplementation in feeds, it is imperative to find iron sources favored by animals but not by *Salmonella*. It is believed that the supplementation of iron increases the virulence of *Salmonella* (Kortman et al. 2012). Our results of *in vitro* growth of *Salmonella* under the medium containing different iron sources were consistent with the previous findings. Moreover, our results indicated that the growth of *Salmonella* could be affected by the iron forms supplemented into the medium. Several studies demonstrated that addition of iron-amino acid chelates in the diets of broiler chickens could be more effective than the addition of inorganic iron in terms of bioavailability, production and health performance (Shinde et al., 2011, Kwiecień et al., 2015; Jarosz et al., 2016). However, there is no information on the effects of iron amino acid chelates on the growth, colonization and virulence of *Salmonella* in animal guts although some novel iron sources and iron chelators (e.g. gallium, apo-lactoferrin, and iron amino acid chelates) have shown the ability of inhibiting the growth and/or infection of some enterica pathogens such as *Clostridium difficile* (Cruz-Huerta et al., 2016; Chilton et al., 2016; Perl and Moalem, 2018). Therefore, the effects of iron amino acid chelates on the growth, colonization, and virulence of *Salmonella* must be further investigated with *in vitro* and *in vivo* approaches.

With the recent advances in sequencing technologies and “omic” tools, it becomes possible to comprehensively study dietary components (e.g. iron sources and iron chelators) and their benefits to the health and nutrition of animals, leading to sustainable food animal productions (Gong et al., 2018). Our results on the host response of Caco-2 cells and *C.*

elegans indicated that the virulence of iron-uptake defective mutants of *Salmonella* is attenuated. However, interactions among the three components (iron sources, *Salmonella* and host) in the gut ecosystem are still not clear. Therefore, it is imperative to investigate the transcriptome and proteome profiles to understand the response of *Salmonella* to treatments. On the other hand, it is worth measuring the transcriptome and proteome profiles of hosts (e.g. Caco-2 cell, *C. elegans*, and poultry intestines) infected with wild-type and iron-uptake defective mutants of *Salmonella*. The gut microbiota and its interactions with animal hosts and diets have been of research interest for a long time (Gong et al., 2018). The composition and diversity of animal gut microbiota can be affected by many different factors including iron sources, iron chelators and iron-uptake defective mutants of *Salmonella*. Therefore, more comprehensive studies of the composition and functionality of gut microbiota (referred to as microbiome) will significantly enrich our knowledge of their interactions. Further *in vivo* studies are required to elucidate the molecular mechanisms of the interaction between the iron-uptake defective mutant and the host in experimentally infected poultry with the integrated use of gnotobiotic and knock-out/transgenic animals, the “omics” tools, and bioinformatics and statistical approaches.

5.2 GENERAL CONCLUSION

Our results suggest that iron chelators can inhibit the growth of wild-type and iron-uptake defective mutants of *Salmonella* and iron uptake systems are required for the survival, colonization, virulence of *Salmonella* in animal guts. These findings could help to develop natural compounds and biocontrol agents (e.g. specific iron sources and iron chelators) based on iron uptake system proteins for the control of *Salmonella* to mitigate potential threats to public health, enhance consumer confidence in Canadian agri-food

products and reduce the cost associated with foodborne illness. Additionally, this study offers possible approaches for future research of other bacterial pathogens, such as verotoxigenic *E. coli*.

CHAPTER 6 FUTURE DIRECTIONS

Future directions include:

- 1) To investigate the ability of wild-type and iron-uptake defective mutants of *Salmonella* to infect the host with the ligated poultry intestines and *in vivo* animal trials;
- 2) To examine the bactericidal activity of the chelators (e.g. 2,2'-dipyridyl) in different models (*C. elegans*, the ligated poultry intestines and *in vivo* animal trials);
- 3) To evaluate the effects of iron chelators on the survival of wild-type and iron-uptake mutants of *Salmonella* in poultry litter;
- 4) To determine the transcriptome and proteome profiles of wild-type and iron-uptake mutants of *Salmonella* in response to different concentrations of iron chelators;
- 5) To measure the transcriptome and proteome profiles of hosts (e.g. Caco-2 cell, *C. elegans*, and poultry intestines) when infected with wild-type and iron-uptake defective mutants of *Salmonella*.

CHAPTER 7 LITERATURE CITED

- Abate, F., R. Cozzi, M. Maritan, P. Lo Surdo, D. Maione, E. Malito, and M. J. Bottomley. 2016. Crystal structure of FhuD at 1.6 Å resolution: a ferrichrome-binding protein from the animal and human pathogen *Staphylococcus pseudintermedius*. *Acta Crystallogr. Sect. F Struct. Biol. Commun.* 72:214-219.
- Akter, M., P. A. Iji, and H. Graham. 2017. Increased iron level in phytase-supplemented diets reduces performance and nutrient utilization in broiler chickens. *Br. Poultry Sci.* 58:409-417.
- Allerberger, F., A. Liesegang, K. Grif, D. Khaschabi, R. Prager, J. Danzl, F. Höck, J. Öttl, M. P. Dierich, and C. Berghold. 2003. Occurrence of *Salmonella enterica* serovar Dublin in Austria. *Wien Med Wochenschr.* 153:148-152.
- Almiron, M., A. J. Link, D. Furlong, and R. Kolter. 1992. A novel DNA-binding protein with regulatory and protective roles in starved *Escherichia coli*. *Genes. Dev.* 6:2646-2654.
- Alpuche-Aranda, C. M., E. L. Racoosin, J. A. Swanson, and S. I. Miller. 1994. *Salmonella* stimulate macrophage macropinocytosis and persist within spacious phagosomes. *J. Exp. Med.* 179:601-608.
- Alper, S., S. J. McBride, B. Lackford, J. H. Freedman, and D. A. Schwartz. 2007. Specificity and complexity of the *Caenorhabditis elegans* innate immune response. *Mol. Cell. Biol.* 27(15):5544-5553.
- Altier, C. 2005. Genetic and environmental control of *Salmonella* invasion. *J. Microbiol.* 43(1):85-92.
- Amano, F. 2011. *Salmonella* Dps, a Key Molecule Bearing Both Pathogenicity and Resistance to Environmental Stresses in *Salmonella*. *J. Health Sci.* 57:458-471.

- Andreini, C., I. Bertini, G. Cavallaro, G. L. Holliday, and J. M. Thornton. 2008. Metal ions in biological catalysis: from enzyme databases to general principles. *J. Biol. Inorg. Chem.* 13:1205-1218.
- Andrews, N. C., and P. J. Schmidt. 2007. Iron homeostasis. *Annu. Rev. Physiol.* 69:69-85.
- Andrews, S. C. 1998. Iron storage in bacteria. *Adv. Microb. Physiol.* 40:281-351.
- Andrews, S. C. 2010. The Ferritin-like superfamily: Evolution of the biological iron storeman from a rubrerythrin-like ancestor. *Biochim. Biophys. Acta. Gen. Subj.* 1800:691-705.
- Andrews, S. C., A. K. Robinson, and F. Rodríguez-Quñones. 2003. Bacterial iron homeostasis. *FEMS Microbiol. Rev.* 27:215-237.
- Arnold, J. W., D. W. Niesel, C. R. Annable, C. B. Hess, M. Asuncion, Y. J. Cho, J. W. Peterson, and G. R. Klimpel. 1993. Tumor necrosis factor- α mediates the early pathology in *Salmonella* infection of the gastrointestinal tract. *Microb. Pathog.* 14(3):217-227.
- Arosio, P., L. Elia, and M. Poli. 2017. Ferritin, cellular iron storage and regulation. *IUBMB Life.* 69:414-422.
- Arosio, P., R. Ingrassia, and P. Cavadini. 2009. Ferritins: a family of molecules for iron storage, antioxidation and more. *Biochim. Biophys. Acta. Gen. Subj.* 1790:589-599.
- ATCC.org.Caco-2 [Caco2] ATCC[®] HTB-37[™] Homo sapiens Colon Colorectal. URL(<https://www.atcc.org/products/all/HTB-37.aspx#culturemethod>).
- Awad, W., and K. Ghareeb. 2014. Some aspects of control of *Salmonella* infection in poultry for minimising contamination in the food chain. *Worlds Poult. Sci. J.* 70:519-530.

- Aznar, R., C. Amaro, E. Alcaide, and M. L. Lemos. 1989. Siderophore production by environmental strains of *Salmonella* species. FEMS Microbiol. Lett. 57:7-12.
- Bai, S., Zhang, K., Ding, X., Wang, J., Zeng, Q., Peng, H., Xuan, Y., Su, Z. and Bai, J., 2018. High dietary iron differentially influences the iron distribution in the livers and the spleens of laying hens after *Salmonella* Typhimurium infection. Biol. Trace. Elem. Res. 1-12.
- Balan, K. V., and U. S. Babu. 2017. Comparative responses of chicken macrophages to infection with *Salmonella enterica* serovars. Poult. Sci. 96:1849-1854.
- Balbontín, R., N. Villagra, M. Pardos de la Gándara, G. Mora, N. Figueroa-Bossi, and L. Bossi. 2016. Expression of IroN, the salmochelin siderophore receptor, requires mRNA activation by RyhB small RNA homologues. Mol. Microbiol. 100:139-155.
- Baldus, W., V. Fairbanks, E. Dickson, and A. Baggenstoss. 1978. Deferoxamine-chelatable iron in hemochromatosis and other disorders of iron overload. Mayo Clin. Proc. 53:157-165
- Banerjee, S., S. Paul, L. T. Nguyen, B. C. Chu, and H. J. Vogel. 2016. FecB, a periplasmic ferric-citrate transporter from *E. coli*, can bind different forms of ferric-citrate as well as a wide variety of metal-free and metal-loaded tricarboxylic acids. Metallomics. 8:125-133.
- Barrow, P., M. Huggins, M. Lovell, and J. Simpson. 1987. Observations on the pathogenesis of experimental *Salmonella typhimurium* infection in chickens. Res. Vet. Sci. 42:194-199.
- Barrow, P. A., and O. C. Frietas Neto. 2011. Pullorum disease and fowl typhoid-new thoughts on old diseases: a review. Avian. Pathol. 40:1-13.
- Basnet, H. B., H. J. Kwon, S. H. Cho, S. J. Kim, H. S. Yoo, Y. H. Park, S. I. Yoon, N. S. Shin, and H. J. Youn. 2008. Reproduction of fowl typhoid by respiratory challenge with *Salmonella Gallinarum*. Avian. Dis. 52:156-159.

- Beinert, H., R. H. Holm, and E. Münck. 1997. Iron-sulfur clusters: nature's modular, multipurpose structures. *Science*. 277:653-659.
- Benjamin, W., C. Turnbough, B. Posey, and D. Briles. 1985. The ability of *Salmonella typhimurium* to produce the siderophore enterobactin is not a virulence factor in mouse typhoid. *Infect. Immun.* 50:392-397.
- Bertini, I., H. B. Gray, S. J. Lippard, and J. S. Valentine. 1994. *Bioinorganic chemistry*. University Science Books. Mill Valley, CA.
- Bess, F., S. L. Vieira, A. Favero, R. A. Cruz, and P. C. Nascimento. 2012. Dietary iron effects on broiler breeder performance and egg iron contents. *Anim. Feed Sci. Technol.* 178:67-73.
- Bodavari, S. 2006. *The merck index*. 12th rev. ed. Whitehouse Station Press, New York, NJ.
- Bothwell, T., G. Pirzio-Biroli, and C. Finch. 1979. *Iron metabolism in man*. Blackwell Scientific Press, Oxford, England. p. 256-283
- Bovell-Benjamin, A. C., F. E. Viteri, and L. H. Allen. 2000. Iron absorption from ferrous bisglycinate and ferric trisglycinate in whole maize is regulated by iron status. *Am. J. Clin. Nutr.* 71:1563-1569.
- Brasse-Lagnel, C., Z. Karim, P. Letteron, S. Bekri, A. Bado, and C. Beaumont. 2011. Intestinal DMT1 cotransporter is down-regulated by hepcidin via proteasome internalization and degradation. *Gastroenterology*. 140:1261-1271.
- Braun, V., K. Hantke, and W. Koester. 1998. Bacterial iron transport: mechanisms, genetics, and regulation. *Met. Ions Biol. Syst.* 35:67-146.
- Brenner, F., R. Villar, F. Angulo, R. Tauxe, and B. Swaminathan. 2000. *Salmonella* nomenclature. *J. Clin. Microbiol.* 38:2465-2467.
- Buchanan, S. K., B. S. Smith, L. Venkatramani, D. Xia, L. Esser, M. Palnitkar, R. Chakraborty, D. van der Helm, and J. Deisenhofer. 1999. Crystal structure of the

- outer membrane active transporter FepA from *Escherichia coli*. *Nat. Struct. Mol. Biol.* 6:56-63.
- Cassat, J. E., and E. P. Skaar. 2013. Iron in infection and immunity. *Cell. Host. Microbe.* 13:509-519.
- Cavill, I., M. Worwood, and A. Jacobs. 1975. Internal regulation of iron absorption. *Nature.* 256:328-329.
- Cercamondi, C. I., I. M. Egli, E. Ahouandjinou, R. Dossa, C. Zeder, L. Salami, H. Tjalsma, E. Wiegerinck, T. Tanno, and R. F. Hurrell. 2010. Afebrile *Plasmodium falciparum* parasitemia decreases absorption of fortification iron but does not affect systemic iron utilization: a double stable-isotope study in young Beninese women. *Am. J. Clin. Nutr.* 92:1385-1392.
- Chakravorty, D., I. Hansen-Wester, and M. Hensel. 2002. *Salmonella* pathogenicity island 2 mediates protection of intracellular *Salmonella* from reactive nitrogen intermediates. *J. Exp Med.* 195:1155-1166.
- Chanana, V., S. Negi, H. Chander, R. P. Tiwari, and P. Rishi. 2004. Apoptotic cell death of macrophages by iron-stressed *Salmonella enterica* serovar Typhimurium. *World J. Microbiol. Biotechnol.* 20:887-893.
- Chanana, V., S. Majumdar, P. Ray, M. Sharma, and P. Rishi. 2006. Coordinated expression and immunogenicity of an outer membrane protein from *Salmonella enterica* serovar Typhi under iron limitation, oxidative stress and anaerobic conditions. *J. Biomed. Sci.* 13:303–312.
- Charlton, R. W., and T. H. Bothwell. 1983. Iron absorption. *Annu. Rev. Med.* 34:55-68.
- Cherayil, B. J. 2011. The role of iron in the immune response to bacterial infection. *Immunol. Res.* 50:1-9.
- Chua, A. C., and E. H. Morgan. 1997. Manganese metabolism is impaired in the Belgrade laboratory rat. *J. Comp. Physiol. B* 167:361-369.
- Clifton-Hadley, F., M. Breslin, L. Venables, K. Springs, S. Cooles, S. Houghton, and

- M. J. Woodward. 2002. A laboratory study of an inactivated bivalent iron restricted *Salmonella enterica* serovars Enteritidis and Typhimurium dual vaccine against Typhimurium challenge in chickens. *Vet. Microbiol.* 89:167-179.
- Collins, H. L. 2003. The role of iron in infections with intracellular bacteria. *Immunol. Lett.* 85:193-195.
- Collins, J. F., C. A. Franck, K. V. Kowdley, and F. K. Ghishan. 2005. Identification of differentially expressed genes in response to dietary iron deprivation in rat duodenum. *Am. J. Gastr. Liver Physiol.* 288:G964-G971.
- Colonna, B., M. Nicoletti, P. Visca, M. Casalino, P. Valenti, and F. Maimone. 1985. Composite IS1 elements encoding hydroxamate-mediated iron-uptake in FIme plasmids from epidemic *Salmonella* spp. *J. Bacteriol.* 162:307-316.
- Cook, J. D., D. A. Lipschitz, L. E. Miles, and C. A. Finch. 1974. Serum ferritin as a measure of iron stores in normal subjects. *Am. J. Clin. Nutr.* 27:681-687.
- Cornelissen, C. N., and P. F. Sparling. 1994. Iron piracy: acquisition of transferrin-bound iron by bacterial pathogens. *Mol. Microbiol.* 14:843-850.
- Cowland, J. B., and N. Borregaard. 1997. Molecular characterization and pattern of tissue expression of the gene for neutrophil gelatinase-associated lipocalin from humans. *Genomics.* 45:17-23.
- Chandraleka, S., K. Ramya, G. Chandramohan, D. Dhanasekaran, A. Priyadharshini, and A. Panneerselvam. 2014. Antimicrobial mechanism of copper (II) 1, 10-phenanthroline and 2, 2'-bipyridyl complex on bacterial and fungal pathogens. *J. Saudi Chem. Soc.* 18(6):953-962.
- Chase, D.L. and Koelle, M.R. 2007. Biogenic amine neurotransmitters in *C. elegans*. In *WormBook: The Online Review of C. elegans Biology.* WormBook.
- Chu, B. C., A. Garcia-Herrero, T. H. Johanson, K. D. Krewulak, C. K. Lau, R. S.

- Peacock, Z. Slavinskaya, and H. J. Vogel. 2010. Siderophore uptake in bacteria and the battle for iron with the host; a bird's eye view. *Biometals*. 23(4):601-611.
- Coburn, B., G. A. Grassl, and B. Finlay. 2007. *Salmonella*, the host and disease: a brief review. *Immunol. Cell Biol.* 85(2):112-118.
- Cossart, P., and P. J. Sansonetti. 2004. Bacterial invasion: the paradigms of enteroinvasive pathogens. *Science*. 304(5668):242-248.
- Crabtree, J., J. Wyatt, L. Trejdosiewicz, P. Peichl, P. Nichols, N. Ramsay, J. Primrose, and I. Lindley. 1994. Interleukin-8 expression in *Helicobacter pylori* infected, normal, and neoplastic gastroduodenal mucosa. *J. Clin. Pathol.* 47(1):61-66.
- Cuadras, M. A., D. A. Feigelstock, S. An, and H. B. Greenberg. 2002. Gene expression pattern in Caco-2 cells following rotavirus infection. *J. Virol.* 76(9):4467-4482.
- Davies, N., and R. Nightingale. 1975. The effects of phytate on intestinal absorption and secretion of zinc, and whole-body retention of Zn, copper, iron and manganese in rats. *B. J. Nutr.* 34:243-258.
- Datsenko, K. A., and B. L. Wanner. 2000. One-step inactivation of chromosomal genes in *Escherichia coli* K-12 using PCR products. *Proc. Natl. Acad. Sci.* 97(12):6640-6645.
- De Domenico, I., D. M. Ward, C. Langelier, M. B. Vaughn, E. Nemeth, W. I. Sundquist, T. Ganz, G. Musci, and J. Kaplan. 2007. The molecular mechanism of hepcidin-mediated ferroportin down-regulation. *Mol. Biol. Cell.* 18:2569-2578.
- Deiwick, J., S. P. Salcedo, E. Boucrot, S. M. Gilliland, T. Henry, N. Petermann, S. R. Waterman, J.-P. Gorvel, D. W. Holden, and S. Méresse. 2006. The translocated

- Salmonella* effector proteins SseF and SseG interact and are required to establish an intracellular replication niche. *Infect. Immun.* 74:6965-6972.
- Deriu, E., J. Z. Liu, M. Pezeshki, R. A. Edwards, R. J. Ochoa, H. Contreras, S. J. Libby, F. C. Fang, and M. Raffatellu. 2013. Probiotic bacteria reduce *Salmonella typhimurium* intestinal colonization by competing for iron. *Cell. Host. Microbe.* 14:26-37.
- Deriu, E., J. Z. Liu, and M. Raffatellu. 2011. Stress response in pathogenic bacteria, S. P. Kidd ed. CAB Int. Wallingford, UK. p. 283-296
- Dhanani, A. S., G. Block, K. Dewar, V. Forgetta, E. Topp, R. G. Beiko, and M. S. Diarra. 2015. Genomic comparison of non-typhoidal *Salmonella enterica* serovars Typhimurium, Enteritidis, Heidelberg, Hadar and Kentucky isolates from broiler chickens. *PLoS One.* 10(6):e0128773.
- Ding, C., X. Cong, X. M. Zhang, S. L. Li, L. L. Wu, and G. Y. Yu. 2017. Decreased interaction between ZO-1 and occludin is involved in alteration of tight junctions in transplanted epiphora submandibular glands. *J. Mol. Histol.* 48(3):225-234.
- Dostal, A., M. Gagnon, C. Chassard, M. B. Zimmermann, L. O'Mahony, and C. Lacroix. 2014. *Salmonella* adhesion, invasion and cellular immune responses are differentially affected by iron concentrations in a combined in vitro gut fermentation-cell model. *PLoS One.* 9:e93549.
- Eisenmann, D. M. Wnt signaling. 2005. WormBook. The *C. elegans* Research Community.
- Egan, T. J., K. R. Koch, P. L. Swan, C. Clarkson, D. A. Van Schalkwyk, and P. J. Smith. 2004. *In vitro* antimalarial activity of a series of cationic 2, 2'-bipyridyl-and 1, 10-phenanthrolineplatinum (II) benzoylthiourea complexes. *J. Med. Chem.*

47(11):2926-2934.

- El-Gendy, N., J. Qian, K. Eshelman, M. Rivera, and C. Berkland. 2015. Antibiotic activity of iron-sequestering polymers. *Biomacromolecules*. 16:1480-1488.
- Eng, S. K., P. Pusparajah, N. S. Ab Mutalib, H. L. Ser, K. G. Chan, and L. H. Lee. 2015. *Salmonella*: A review on pathogenesis, epidemiology and antibiotic resistance. *Front. Life. Sci.* 8:284-293.
- Fàbrega, A., and J. Vila. 2013. *Salmonella enterica* serovar Typhimurium skills to succeed in the host: virulence and regulation. *Clin. Microbiol. Rev.* 26:308-341.
- Feng, J., W. Ma, Z. Xu, J. He, Y. Wang, and J. Liu. 2009. The effect of iron glycine chelate on tissue mineral levels, fecal mineral concentration, and liver antioxidant enzyme activity in weanling pigs. *Anim. Feed. Sci. Technol.* 150:106-113.
- Feng, Y., B. G. Williams, F. Koumanov, A. J. Wolstenholme, and G. D. Holman. 2013. FGT-1 is the major glucose transporter in *C. elegans* and is central to aging pathways. *Biochem. J.* 456(2):219-229.
- Ferguson, A. D., R. Chakraborty, B. S. Smith, L. Esser, D. van der Helm, and J. Deisenhofer. 2002. Structural basis of gating by the outer membrane transporter FecA. *Science*. 295:1715-1719.
- Ferguson, A. D., E. Hofmann, J. W. Coulton, K. Diederichs, and W. Welte. 1998. Siderophore-mediated iron transport: crystal structure of FhuA with bound lipopolysaccharide. *Science*. 282:2215-2220.
- Finch, C. A., H. Huebers, M. Eng, and L. Miller. 1982. Effect of transfused reticulocytes on iron exchange. *Blood*. 59:364-369.
- Finlay, B. B., S. Ruschkowski, and S. Dedhar. 1991. Cytoskeletal rearrangements accompanying *Salmonella* entry into epithelial cells. *J. Cell. Sci.* 99:283-296.
- Finlay, B. B., and S. Falkow. 1990. *Salmonella* interactions with polarized human

- intestinal Caco-2 epithelial cells. *J. Infect. Dis.* 162(5):1096-1106.
- Fischbach, M. A., H. Lin, L. Zhou, Y. Yu, R. J. Abergel, D. R. Liu, K. N. Raymond, B. L. Wanner, R. K. Strong, and C. T. Walsh. 2006. The pathogen-associated *iroA* gene cluster mediates bacterial evasion of lipocalin 2. *Proc. Natl. Acad. Sci.* 103:16502-16507.
- Fox, T. E., J. Eagles, and S. J. Fairweather-Tait. 1998. Bioavailability of iron glycine as a fortificant in infant foods. *Am. J. Clin. Nutr.* 67:664-668.
- Francis, C., M. Starnbach, and S. Falkow. 1992. Morphological and cytoskeletal changes in epithelial cells occur immediately upon interaction with *Salmonella typhimurium* grown under low-oxygen conditions. *Mol. Microbiol.* 6:3077-3087.
- Francis, C. L., T. A. Ryan, B. D. Jones, S. J. Smith, and S. Falkow. 1993. Ruffles induced by *Salmonella* and other stimuli direct macropinocytosis of bacteria. *Nature.* 364:639.
- Frawley, E. R., and F. C. Fang. 2014. The ins and outs of bacterial iron metabolism. *Mol. Microbiol.* 93:609-616.
- Furman, M., A. Fica, M. Saxena, J. L. Di Fabio, and F. C. Cabello. 1994. *Salmonella typhi* iron-uptake mutants are attenuated in mice. *Infect. Immun.* 62:4091-4094.
- Ganz, T. 2003. Defensins: antimicrobial peptides of innate immunity. *Nat. Rev. Immunol.* 3:710.
- Ganz, T., and E. Nemeth. 2011. Hepcidin and disorders of iron metabolism. *Annu. Rev. Med.* 62:347-360.
- Ganz, T., and E. Nemeth. 2015. Iron homeostasis in host defence and inflammation. *Nat. Rev. Immunol.* 15:500
- Garcia-del Portillo, F., and B. B. Finlay. 1994. *Salmonella* invasion of nonphagocytic cells induces formation of macropinosomes in the host cell. *Infect. Immun.* 62:4641-4645.

- Garcia-del Portillo, F., and B. B. Finlay. 1995. Targeting of *Salmonella typhimurium* to vesicles containing lysosomal membrane glycoproteins bypasses compartments with mannose 6-phosphate receptors. *J. Cell. Biol.* 129:81-97.
- Garcia-del Portillo, F., J. W. Foster, and B. Finlay. 1993a. Role of acid tolerance response genes in *Salmonella typhimurium* virulence. *Infect. Immun.* 61:4489-4492.
- Garcia-del Portillo, F., M. B. Zwick, K. Y. Leung, and B. B. Finlay. 1993b. *Salmonella* induces the formation of filamentous structures containing lysosomal membrane glycoproteins in epithelial cells. *Proc. Natl. Acad. Sci.* 90:10544-10548.
- Gast, R. K., R. Guraya, J. Guard-Bouldin, P. S. Holt, and R. W. Moore. 2007. Colonization of specific regions of the reproductive tract and deposition at different locations inside eggs laid by hens infected with *Salmonella* Enteritidis or *Salmonella* Heidelberg. *Avian. Dis.* 51:40-44.
- Giannasca, K. T., P. J. Giannasca, and M. R. Neutra. 1996. Adherence of *Salmonella typhimurium* to Caco-2 cells: identification of a glycoconjugate receptor. *Infect. Immun.* 64(1):135-145.
- Golding, S., and S. Young. 1995. Iron Requirements of Human Lymphocytes: Relative Contributions of Intra-and Extra-Cellular Iron. *Scand. J. Immunol.* 41:229-236.
- Gong, J., Yang, C. and Khafipour, E., 2018. Molecular and “Omics” techniques for studying gut microbiota relevant to food animal production. *Molecular Techniques in Food Biology: Safety, Biotechnology, Authenticity and Traceability.* John Wiley & Sons, Inc, New York, NJ. p. 71.
- Gräsbeck, R., R. Majuri, I. Kouvonen, and R. Tenhunen. 1982. Spectral and other studies on the intestinal haem receptor of the pig. *Biochim. Biophys. Acta. Protein. Struct. Mol. Enzymol.* 700:137-142.

- Gresock, M. G., and K. Postle. 2017. Going outside the TonB box: identification of novel FepA-TonB interactions in vivo. *J. Bacteriol.* 199:e00649-00616.
- Guerinot, M. L. 1994. Microbial iron transport. *Annu. Rev. Microbiol.* 48:743-772.
- Guo, Z. Y., L. Li, Q. L. Fan, X. J. Lin, Z. Y. Jiang, C. T. Zheng, F. Y. Ding, and S. Q. Jiang. 2018. Effects of oxidative stress induced by high dosage of dietary iron ingested on intestinal damage and caecal microbiota in Chinese Yellow broilers. *J. Anim. Physiol. Anim. Nutr (Berl)*. 102(4):924-932.
- Haikarainen, T., and A. C. Papageorgiou. 2010. Dps-like proteins: structural and functional insights into a versatile protein family. *Cell. Mol. Life. Sci.* 67:341-351.
- Hallberg, L. 1981. Bioavailability of dietary iron in man. *Annu. Rev. Nutr.* 1:123-147.
- Hannavy, K., G. Barr, C. Dorman, J. Adamson, L. Mazengera, M. Gallagher, J. Evans, B. Levine, I. Trayer, and C. Higgins. 1990. TonB protein of *Salmonella typhimurium*: a model for signal transduction between membranes. *J. Mol. Biol.* 216(4):897-910.
- Hassan, Y.I., Lahaye, L., Gong, M.M., Peng, J., Gong, J., Liu, S., Gay, C.G. and Yang, C. 2018. Innovative drugs, chemicals, and enzymes within the animal production chain. *Vet. Res.* 49(1), 71
- Head, B.P., Olaitan, A.O. and Aballay, A. 2017. Role of GATA transcription factor ELT-2 and p38 MAPK PMK-1 in recovery from acute *P. aeruginosa* infection in *C. elegans*. *Virulence.* 8:261-274.
- Hentze, M. W., M. U. Muckenthaler, B. Galy, and C. Camaschella. 2010. Two to tango: regulation of Mammalian iron metabolism. *Cell.* 142:24-38.
- Hickman, S. J., R. E. Cooper, L. Bellucci, E. Paci, and D. J. Brockwell. 2017. Gating

- of TonB-dependent transporters by substrate-specific forced remodeling. *Nat. Comm.* 8.
- Higgs, P. I., P. S. Myers, and K. Postle. 1998. Interactions in the TonB-dependent energy transduction complex: ExbB and ExbD form homomultimers. *J. Bacteriol.* 180:6031-6038.
- Hobbie, S., L. M. Chen, R. Davis, and J. Galan. 1997. Involvement of mitogen-activated protein kinase pathways in the nuclear responses and cytokine production induced by *Salmonella typhimurium* in cultured intestinal epithelial cells. *J. Immunol.* 159:5550-5559.
- Holden, V. I., P. Breen, S. Houle, C. M. Dozois, and M. A. Bachman. 2016. *Klebsiella pneumoniae* Siderophores induce inflammation, bacterial dissemination, and HIF-1 α stabilization during pneumonia. *MBio.* 7:e01397-01316.
- Hooda, J., A. Shah, and L. Zhang. 2014. Heme, an essential nutrient from dietary proteins, critically impacts diverse physiological and pathological processes. *Nutrients.* 6:1080-1102.
- Hubbard, J., G. Harman, and Y. Hadar. 1983. Effect of soilborne *Pseudomonas* spp. on the biological control agent. *Trichoderma hamatum.* 655-659.
- Hunt, P.R. 2017. The *C. elegans* model in toxicity testing. *J. Appl. Toxicol.* 37:50-59.
- Humphrey, T., A. Baskerville, H. Chart, and B. Rowe. 1989. Infection of egg-laying hens with *Salmonella enteritidis* PT4 by oral inoculation. *Vet. Rec.* 125:531-532.
- Hsin, H. and Kenyon, C. 1999. Signals from the reproductive system regulate the lifespan of *C. elegans*. *Nature.* 399:362.
- Ilyin, G., B. Courselaud, M.-B. Troadec, C. Pigeon, M. Alizadeh, P. Leroyer, P. Brissot, and O. Loréal. 2003. Comparative analysis of mouse hepcidin 1 and 2 genes: evidence for different patterns of expression and co-inducibility during iron overload 1. *FEBS Lett.* 542:22-26.
- Irazoqui, J. E., J. M. Urbach, and F. M. Ausubel. 2010. Evolution of host innate defence:

- insights from *Caenorhabditis elegans* and primitive invertebrates. Nat. Rev. Immunol. 10(1):47.
- Jarosz, Ł., M. Kwiecień, A. Marek, Z. Grądzki, A. Winiarska-Mieczan, M. Kalinowski, and E. Laskowska. 2016. Effects of feed supplementation with glycine chelate and iron sulfate on selected parameters of cell-mediated immune response in broiler chickens. Res. Vet. Sci. 107:68-74.
- Jain, S., Mukhopadhyay, K. and Thomassin, P.J. 2019. An economic analysis of salmonella detection in fresh produce, poultry, and eggs using whole genome sequencing technology in Canada. Food Res. Int. 116:802-809.
- Jia, Y., M. Jiang, J. Sun, R. Shi, and D. Liu. 2015. Studies on different iron source absorption by in situ ligated intestinal loops of broilers. Biol. Trace. Elem. Res. 163(1-2):154-161.
- Jenssen, H., and R. E. Hancock. 2009. Antimicrobial properties of lactoferrin. Biochimie. 91:19-29.
- Jones, B. D., N. Ghori, and S. Falkow. 1994. *Salmonella typhimurium* initiates murine infection by penetrating and destroying the specialized epithelial M cells of the Peyer's patches. J. Exp. Med. 180:15-23.
- Jones, B. D., and S. Falkow. 1996. Salmonellosis: host immune responses and bacterial virulence determinants. Annu. Rev. Immunol. 14(1):533-561.
- Jordan, I., and J. Kaplan. 1994. The mammalian transferrin-independent iron transport system may involve a surface ferrireductase activity. Biochem. J. 302:875-879.
- Kaneshige, T., K. Yaguchi, and T. Ohgitani. 2009. Siderophore receptor IroN is an important protective antigen against *Salmonella* infection in chickens. Avian. Dis. 53:563-567.
- Kamaladevi, A., and K. Balamurugan. 2016. *Lactobacillus casei* triggers a TLR

mediated RACK-1 dependent p38 MAPK pathway in *Caenorhabditis elegans* to resist *Klebsiella pneumoniae* infection. *Food. Funct.* 7(7):3211-3223.

Kegley, E., J. Spears, W. Flowers, and W. Schoenherr. 2002. Iron methionine as a source of iron for the neonatal pig1. *Nutr. Res.* 22:1209-1217.

Kemna, E. H., H. Tjalsma, H. L. Willems, and D. W. Swinkels. 2008. Hepcidin: from discovery to differential diagnosis. *Haematologica.* 93:90-97.

Ketting, R. F., M. Tijsterman, and R. H. Plasterk. 2006. Isolation of RNA from *C. elegans*. *Cold Spring Harbor Protocols.*

Khattak F., V. Paschalis, M. Green, J. Houdijk, P. Sultanas, and J. Mahdavi. 2018. TYPLEX[®] Chelate, a novel feed additive, inhibits *Campylobacter jejuni* biofilm formation and cecal colonization in broiler chickens. *Poult. Sci.* 97:1391-1399.

Kim, Y.-I., J. H. Cho, O. J. Yoo, and J. Ahn. 2004. Transcriptional regulation and life-span modulation of cytosolic aconitase and ferritin genes in *C. elegans*. *J. Mol. Biol.* 342(2):421-433.

Kingsley, R., W. Rabsch, P. Stephens, M. Roberts, R. Reissbrodt, and P. H. Williams. 1995. Iron supplying systems of *Salmonella* in diagnostics, epidemiology and infection. *FEMS Immunol. Med. Microbiol.* 11:257-264.

Knodler, L. A., B. A. Vallance, M. Hensel, D. Jäckel, B. B. Finlay, and O. Steele-Mortimer. 2003. *Salmonella* type III effectors PipB and PipB2 are targeted to detergent-resistant microdomains on internal host cell membranes. *Mol. Microbiol.* 49:685-704.

Kochetkova, N., I. Yakovleva, A. Shaposhnikov, T. Shevchenko, and L. Zakirova. 2016. Chelate complexes of malic or citric acids with iron, manganese and zinc as a biologically active supplement for broiler chicken diet. *Res. Res. Pharm.* 2(4).

Kogut, M.H. and Arsenault, R.J. 2017. Immunometabolic phenotype alterations

- associated with the induction of disease tolerance and persistent asymptomatic infection of *Salmonella* in the chicken intestine. *Front. Immunol.* 8:372.
- Kortman, G. A., A. Boleij, D. W. Swinkels, and H. Tjalsma. 2012. Iron availability increases the pathogenic potential of *Salmonella typhimurium* and other enteric pathogens at the intestinal epithelial interface. *PLoS One.* 7:e29968.
- Kortman, G. A., R. W. Roelofs, D. W. Swinkels, M. I. De Jonge, S. A. Burt, and H. Tjalsma. 2014. Iron-induced virulence of *Salmonella enterica* serovar Typhimurium at the intestinal epithelial interface can be suppressed by carvacrol. *Antimicrob. Agent. Chemother.* 58:1664-1670.
- Köster, W. 2001. ABC transporter-mediated uptake of iron, siderophores, heme and vitamin B 12. *Res. Microbiol.* 152:291-301.
- Kudrat-E-Zahan, M., M. A. Bashar, M. F. Hossen, and M. S. Islam. 2015. Synthesis, spectroscopic, magnetic and biological activity of Cr (III) and Fe (III) complexes with amino acids and heterocyclic amines. *Asian. J. Res. Chem.* 8:74-76.
- Kulkarni, R., H. Shrivastava, A. Mandal, C. Deo, K. Deshpande, R. Singh, and S. Bhanja. 2011. Assessment of growth performance, immune response and mineral retention in colour broilers as influenced by dietary iron. *Anim. Feed Sci. Technol.* 11:81-90.
- Kulshreshtha, G., Borza, T., Rathgeber, B., Stratton, G.S., Thomas, N.A., Critchley, A., Hafting, J. and Prithiviraj, B. 2016. Red seaweeds *Sarcodiotheca gaudichaudii* and *Chondrus crispus* down regulate virulence factors of *Salmonella* Enteritidis and induce immune responses in *Caenorhabditis elegans*. *Front. Microbiol.* 7:421.
- Kumar, R. S., K. Sasikala, and S. Arunachalam. 2008. DNA interaction of some polymer–copper (II) complexes containing 2, 2'-bipyridyl ligand and their antimicrobial activities. *J. Inorg. Biochem.* 102(2):234-241.
- Kumar, D., Choi, S.H., Washicosky, K.J., Eimer, W., Tucker, S.C., Ghofrani, J.,

- Lefkowitz, A., McColl, G., Goldstein, L.E., Tanzi, R.E. and Moir, R.D. 2016. Amyloid- β Protein Protects Against Microbial Infection In Transgenic *C. elegans* and 5XFAD Mice. *Sci Transl Med.* 8: 340ra72.
- Kuvibidila, S. R., D. Kitchens, and B. S. Baliga. 1999. *In vivo* and *in vitro* iron deficiency reduces protein kinase C activity and translocation in murine splenic and purified T cells. *J. Cell. Biochem.* 74:468-478.
- Kwiecien, M., W. Samolinska, and B. Bujanowicz-Haras. 2015. Effects of iron-glycine chelate on growth, carcass characteristic, liver mineral concentrations and haematological and biochemical blood parameters in broilers. *Anim. Physiol. Anim. Nutr.* 99:1184-1196.
- Labrousse, A., S. Chauvet, C. Couillault, C. L. Kurz, and J. J. Ewbank. 2000. *Caenorhabditis elegans* is a model host for *Salmonella typhimurium*. *Curr. Biol.* 10(23):1543-1545.
- Lane, S., Skowron, M., Wong, A., Yongblah, K., Ehling, J. and Walter, P.B. 2017. Isolation and chelation activity of plant phenolic root exudates as potential clinical iron chelators. *Blood.*130:3505-3505
- Larsen, R. A., M. G. Thomas, G. E. Wood, and K. Postle. 1994. Partial suppression of an *Escherichia coli* TonB transmembrane domain mutation ($\Delta V17$) by a missense mutation in ExbB. *Mol. Microbiol.* 13:627-640.
- Laufberger, V. 1937. Sur la cristallisation de la ferritine. *Soc Chim Biol* 19:1575-1582.
- Lau, C. K., K. D. Krewulak, and H. J. Vogel. 2015. Bacterial ferrous iron transport: the Feo system. *FEMS Microbiol. Rev.* 40(2):273-298.
- Leclerc, J.-M., C. M. Dozois, and F. Daigle. 2017. *Salmonella enterica* serovar Typhi siderophore production is elevated and Fur inactivation causes cell filamentation and attenuation in macrophages. *FEMS Microbiol. Lett.* 364:fnx147.

- Leclerc, J. M., C. M. Dozois, and F. Daigle. 2013. Role of the *Salmonella enterica* serovar Typhi Fur regulator and small RNAs RfrA and RfrB in iron homeostasis and interaction with host cells. *Microbiology*. 159:591-602.
- Li, B., N. Li, Y. Yue, X. Liu, Y. Huang, L. Gu, and S. Xu. 2016. An unusual crystal structure of ferric-enterobactin bound FepB suggests novel functions of FepB in microbial iron uptake. *Biochem. Biophys. Res. Comm.* 478:1049-1053.
- Li, X., L. Zhang, L. Zhang, L. Lu, and X. Luo. 2017. Effect of iron source on iron absorption by in situ ligated intestinal loops of broilers. *Anim. Prod. Sci.* 57:308-314.
- Lieu, P. T., M. Heiskala, P. A. Peterson, and Y. Yang. 2001. The roles of iron in health and disease. *Mol. Aspects. Med.* 22:1-87.
- Liu, J. Z., S. Jellbauer, A. J. Poe, V. Ton, M. Pesciaroli, T. E. Kehl-Fie, N. A. Restrepo, M. P. Hosking, R. A. Edwards, and A. Battistoni. 2012. Zinc sequestration by the neutrophil protein calprotectin enhances *Salmonella* growth in the inflamed gut. *Cell. Host. Microbe.* 11:227-239.
- Lin, F., Wu, H., Zeng, M., Yu, G., Dong, S. and Yang, H. 2018. Probiotic/prebiotic correction for adverse effects of iron fortification on intestinal resistance to *Salmonella* infection in weaning mice. *Food. Funct.* 9:1070-1078.
- Liss, V., Swart, A.L., Kehl, A., Hermanns, N., Zhang, Y., Chikkaballi, D., Böhles, N., Deiwick, J. and Hensel, M. 2017. *Salmonella enterica* remodels the host cell endosomal system for efficient intravacuolar nutrition. *Cell. Host. Microbe.* 21:390-402.
- López, M. A., and F. C. Martos. 2004. Iron availability: An updated review. *Int. J. Food. Sci. Nutr.* 55:597-606.
- Luckey, M., J. R. Pollack, R. Wayne, B. N. Ames, and J. Neilands. 1972. Iron uptake in *Salmonella typhimurium*: utilization of exogenous siderochromes as iron carriers. *J. Bacteriol.* 111:731-738.

- Ma, X., X. Liao, L. Lu, S. Li, L. Zhang, and X. Luo. 2016. Determination of dietary iron requirements by full expression of iron-containing enzymes in various tissues of broilers. *J. Nutr.* 146:2267-2273.
- Ma, X. Y., S. B. Liu, L. Lu, S. F. Li, J. J. Xie, L. Y. Zhang, J. H. Zhang, and X. G. Luo. 2014. Relative bioavailability of iron proteinate for broilers fed a casein-dextrose diet1. *Poult. Sci.* 93:556-563.
- Machado, A.C., Boiago, M.M., do Carmo, G.M., Bottari, N.B., Araujo, D.N., Giuriatti, J., Morsch, V.M., Schetinger, M.R.C., Casagrande, R.A., Wisser, C.S. and Stefani, L.M. 2016. Anaemia, serum iron concentrations and δ -Aminolevulinate dehydratase activity in laying hens infected naturally by *Salmonella* Gallinarum. *J. Comp. Pathol.* 155:1-4.
- Mademidis, A., H. Killmann, W. Kraas, I. Flechsler, G. Jung, and V. Braun. 1997. ATP-dependent ferric hydroxamate transport system in *Escherichia coli*: periplasmic FhuD interacts with a periplasmic and with a transmembrane/cytoplasmic region of the integral membrane protein FhuB, as revealed by competitive peptide mapping. *Mol. Microbiol.* 26:1109-1123.
- Mademidis, A., and W. Köster. 1998. Transport activity of FhuA, FhuC, FhuD, and FhuB derivatives in a system free of polar effects, and stoichiometry of components involved in ferrichrome uptake. *Mol. Gen. Genet.* 258(1-2):156-165.
- Maubon, N., M. Le Vee, L. Fossati, M. Audry, E. Le Ferrec, S. Bolze, and O. Fardel. 2007. Analysis of drug transporter expression in human intestinal Caco-2 cells by real-time PCR. *Fundam. Clin. Pharmacol.* 21(6):659-663.
- McGraw, K. J. 2003. Melanins, metals, and mate quality. *Oikos*:402-406.
- Méresse, S., K. E. Unsworth, A. Habermann, G. Griffiths, F. Fang, M. J. Martínez-Lorenzo, S. R. Waterman, J. P. Gorvel, and D. W. Holden. 2001. Remodeling of the actin cytoskeleton is essential for replication of intravacuolar *Salmonella*. *Cell. Microbiol.* 3:567-577.

- Mitterstiller, A. M., D. Haschka, S. Dichtl, M. Nairz, E. Demetz, H. Talasz, M. P. Soares, E. Einwallner, H. Esterbauer, and F. C. Fang. 2016. Heme oxygenase 1 controls early innate immune response of macrophages to *Salmonella typhimurium* infection. *Cell. Microbiol.* 18:1374-1389.
- Moreira, A. C., J. V. Neves, T. Silva, P. Oliveira, M. S. Gomes, and P. N. Rodrigues. 2017. Hepcidin-(in) dependent mechanisms of iron metabolism regulation during infection by *Listeria* and *Salmonella*. *Infect. Immun.* 85:e00353-00317.
- Murphy, C. T., S. A. McCarroll, C. I. Bargmann, A. Fraser, R. S. Kamath, J. Ahringer, H. Li, and C. Kenyon. 2003. Genes that act downstream of DAF-16 to influence the lifespan of *Caenorhabditis elegans*. *Nature.* 424(6946):277.
- Nagy, T. A., S. M. Moreland, H. Andrews-Polymeris, and C. S. Detweiler. 2013. The Ferric Enterobactin Transporter, Fep, is Required for Persistent *Salmonella* Infection. *Infect. Immun.* 81(11), 4063-4070.
- Nairz, M., A. Schroll, T. Sonnweber, and G. Weiss. 2010. The struggle for iron—a metal at the host–pathogen interface. *Cell. Microbiol.* 12:1691-1702.
- Nairz, M., A. Schroll, D. Haschka, S. Dichtl, P. Tymoszuk, E. Demetz, P. Moser, H. Haas, F. C. Fang, and I. Theurl. 2017. Genetic and Dietary Iron Overload Differentially Affect the Course of *Salmonella* Typhimurium Infection. *Front Cell. Infect. Microbiol.* 7.
- Nairz, M., I. Theurl, S. Ludwiczek, M. Theurl, S. M. Mair, G. Fritsche, and G. Weiss. 2007. The co-ordinated regulation of iron homeostasis in murine macrophages limits the availability of iron for intracellular *Salmonella typhimurium*. *Cell. Microbiol.* 9:2126-2140.
- Nairz, M., D. Ferring-Appel, D. Casarrubea, T. Sonnweber, L. Viatte, A. Schroll, D. Haschka, F. C. Fang, M. W. Hentze, and G. Weiss. 2015. Iron regulatory proteins

- mediate host resistance to *Salmonella* infection. *Cell. Host. Microbe* 18:254-261.
- Nakamura, M., N. Nagamine, T. Takahashi, S. Suzuki, and S. Sato. 1994. Evaluation of the efficacy of a bacterin against *Salmonella enteritidis* infection and the effect of stress after vaccination. *Avian. Dis.* 38:717–724.
- National Research Council. 1994. Nutrient requirements of poultry. 9th rev. ed. Natl. Acad. Press, Washington, DC.
- Neilands, J. 1966. Naturally occurring non-porphyrin iron compounds. *Struct. Bonding.* 59-108.
- Neilands, J. 1973. Microbial iron transport compounds (siderochromes). *Inorg. Biochem.* 1:167-202.
- Nemeth, E., M. S. Tuttle, J. Powelson, M. B. Vaughn, A. Donovan, D. M. Ward, T. Ganz, and J. Kaplan. 2004. Hepcidin regulates cellular iron efflux by binding to ferroportin and inducing its internalization. *Science.* 306:2090-2093.
- Nemeth, E., E. V. Valore, M. Territo, G. Schiller, A. Lichtenstein, and T. Ganz. 2003. Hepcidin, a putative mediator of anemia of inflammation, is a type II acute-phase protein. *Blood.* 101:2461-2463.
- Neutra, M. 1989. *Pharmaceutical Applications of Cell and Tissue Culture to Drug Transport.* Springer, Boston, MA. p. 363-398.
- Niecke, M., M. Heid, and A. Krüger. 1999. Correlations between melanin pigmentation and element concentration in feathers of White-tailed Eagles (*Haliaeetus albicilla*). *J. Ornithol.* 140:355-362.
- Noh, H., H. Kim, S. J. Heo, H. H. Cho, and H. B. Koh. 2017. Guanosine-5'-monophosphate-chelated calcium and iron feed additives maintains egg production and prevents *Salmonella Gallinarum* in experimentally infected layers.

- J. Vet. Sci. 18:291-297.
- Norrby, A., and L. Siilvell. 1974. Iron absorption and haemoglobin regeneration in post-haemorrhagic anaemiastudies on the absorption pattern during oral iron therapy Scand. J. Haematol. Suppl. 20:75-106.
- Omonijo, F. A., Ni, L., Gong, J., Wang, Q., Lahaye, L., and Yang, C. 2018. Essential oils as alternatives to antibiotics in swine production. Anim. Nutr. 4(2), 126-136.
- Otto, B., M. Sparrius, A. Verweij-van Vught, and D. MacLaren. 1990. Iron-regulated outer membrane protein of *Bacteroides fragilis* involved in heme uptake. Infect. Immun. 58:3954-3958.
- Pantopoulos, K., S. K. Porwal, A. Tartakoff, and L. Devireddy. 2012. Mechanisms of mammalian iron homeostasis. Biochemistry. 51:5705-5724.
- Parent, E., Archambault, M., Charlebois, A., Bernier-Lachance, J. and Boulianne, M. 2017. A chicken intestinal ligated loop model to study the virulence of *Clostridium perfringens* isolates recovered from antibiotic-free chicken flocks. Avian. Pathol. 46(2), 138-149.
- Park, S., H. Namkung, H. Ahn, and I. Paik. 2004. Production of iron enriched eggs of laying hens. Asian Austr. J. Anim. Sci. 17:1725-1728.
- Peslova, G., J. Petrak, K. Kuzelova, I. Hrdy, P. Halada, P. W. Kuchel, S. Soe-Lin, P. Ponka, R. Sutak, and E. Becker. 2009. Hepcidin, the hormone of iron metabolism, is bound specifically to α -2-macroglobulin in blood. Blood 113:6225-6236.
- Peyssonnaud, C., A. S. Zinkernagel, V. Datta, X. Lauth, R. S. Johnson, and V. Nizet. 2006. TLR4-dependent hepcidin expression by myeloid cells in response to bacterial pathogens. Blood 107:3727-3732.
- Pirzio-Biroli, G., C. A. Finch, and B. Loden. 1960. Iron absorption. 3. The influence of iron stores on iron absorption in the normal subject. J. Lab. Clin. Med. 55:216-

220.

- Pollack, J. R., and J. Neilands. 1970. Enterobactin, an iron transport compound from *Salmonella typhimurium*. *Biochem. Biophys. Res. Comm.* 38:989-992.
- Peterson, M. D., and M. S. Mooseker. 1992. Characterization of the enterocyte-like brush border cytoskeleton of the C2BBE clones of the human intestinal cell line, Caco-2. *J. Cell. Sci.* 102(3):581-600.
- Piana, C., M. Wirth, S. Gerbes, H. Viernstein, F. Gabor, and S. Toegel. 2008. Validation of reference genes for qPCR studies on Caco-2 cell differentiation. *Eur. J. Pharm. Biopharm.* 69(3):1187-1192.
- Pressler, U., H. Staudenmaier, L. Zimmermann, and V. Braun. 1988. Genetics of the iron dicitrate transport system of *Escherichia coli*. *J. Bacteriol.* 170(6):2716-2724.
- Rabsch, W., U. Methner, W. Voigt, H. Tschäpe, R. Reissbrodt, and P. H. Williams. 2003. Role of receptor proteins for enterobactin and 2, 3-dihydroxybenzoylserine in virulence of *Salmonella enterica*. *Infect. Immun.* 71(12):6953-6961.
- Rabsch, W., H. Tschäpe, and A. J. Bäumler. 2001. Non-typhoidal salmonellosis: emerging problems. *Microbes. Infect.* 3(3):237-247.
- Rabsch, W., W. Voigt, R. Reissbrodt, R. M. Tsois, and A. J. Bäumler. 1999. *Salmonella typhimurium* IroN and FepA proteins mediate uptake of enterobactin but differ in their specificity for other siderophores. *J. Bacteriol.* 181(11):3610-3612.
- Rabsch, W., P. Paul, and R. Reissbrodt. 1986. DHBA (2, 3-Dihydroxybenzoesäure) Ausscheidung durch einen enterobactinnegativen multi-resistenten *Salmonella typhimurium*-Wildstamm. *J. Basic. Microbiol.* 26:113-116.

- Rabsch, W., and R. Reissbrodt. 1987. Investigations of *Salmonella* strains from different clinical-epidemiological origin with phenolate and hydroxamate (aerobactin)--siderophore bioassays. *J. Hyg. Epidemiol. Microbiol. Immunol.* 32:353-360.
- Rabsch, W., J. Tkacik, W. Lindemann, I. Mikula, and R. Reissbrodt. 1991. Different systems for iron supply of *Salmonella typhimurium* and *Escherichia coli* wild strains as tool for typing. *Zentralbl Bakteriol.* 274:437-445.
- Raffatellu, M., and A. J. Bäumler. 2010. *Salmonella's* iron armor for battling the host and its microbiota. *Gut. Microbe.* 1:70-72.
- Raffatellu, M., M. D. George, Y. Akiyama, M. J. Hornsby, S.-P. Nuccio, T. A. Paixao, B. P. Butler, H. Chu, R. L. Santos, and T. Berger. 2009. Lipocalin-2 resistance confers an advantage to *Salmonella enterica* serotype Typhimurium for growth and survival in the inflamed intestine. *Cell. Host. Microbe.* 5:476-486.
- Raja, K., R. Simpson, and T. Peters. 1992. Investigation of a role for reduction in ferric iron uptake by mouse duodenum. *Biochim. Biophys. Acta. Mol. Cell. Res.* 1135:141-146.
- Rajashekar, R., D. Liebl, A. Seitz, and M. Hensel. 2008. Dynamic Remodeling of the Endosomal System During Formation of *Salmonella*-Induced Filaments by Intracellular *Salmonella enterica*. *Traffic* 9:2100-2116.
- Rathman, M., L. P. Barker, and S. Falkow. 1997. The unique trafficking pattern of *Salmonella typhimurium*-containing phagosomes in murine macrophages is independent of the mechanism of bacterial entry. *Infect. Immun.* 65:1475-1485.
- Rath, N.C., Liyanage, R., Gupta, A., Packialakshmi, B. and Lay Jr, J.O. 2018. A method to culture chicken enterocytes and their characterization. *Poult. Sci.* 97(11), 4040-4047.
- Ratledge, C., and L. G. Dover. 2000. Iron metabolism in pathogenic bacteria. *Annu. Rev. Microbiol.* 54:881-941.

- Reeves, M. W., G. M. Evins, A. A. Heiba, B. D. Plikaytis, and J. J. Farmer, 3rd. 1989. Clonal nature of *Salmonella typhi* and its genetic relatedness to other *Salmonella* as shown by multilocus enzyme electrophoresis, and proposal of *Salmonella bongori* comb. J. Clin. Microbiol. 27:313-320.
- Rohrbach, M. R., V. Braun, and W. Köster. 1995. Ferrichrome transport in *Escherichia coli* K-12: altered substrate specificity of mutated periplasmic FhuD and interaction of FhuD with the integral membrane protein FhuB. J. Bacteriol. 177:7186-7193.
- Rouf, M. 1964. Spectrochemical analysis of inorganic elements in bacteria. J. Bacteriol. 88:1545-1549.
- Saghizadeh, M., J. M. Ong, W. T. Garvey, R. R. Henry, and P. A. Kern. 1996. The expression of TNF alpha by human muscle. Relationship to insulin resistance. J. Clin. Invest. 97(4):1111-1116.
- Sahler, J.M., Eade, C.R., Altier, C. and March, J.C. 2018. Salmonella enterica serovar Typhimurium increases functional PD-L1 synergistically with gamma interferon in intestinal epithelial cells via Salmonella pathogenicity island 2. Infect. Immun. 86:e00674-17.
- Salehi, S., Howe, K., Lawrence, M.L., Brooks, J.P., Bailey, R.H. and Karsi, A. 2017. Salmonella enterica Serovar Kentucky flagella are required for broiler skin adhesion and Caco-2 cell invasion. Appl. Environ. Microbiol. 83:e02115-16.
- Salcedo, S. P., and D. W. Holden. 2003. SseG, a virulence protein that targets *Salmonella* to the Golgi network. EMBO J. 22:5003-5014.
- Sambuy, Y., I. De Angelis, G. Ranaldi, M. Scarino, A. Stammati, and F. Zucco. 2005. The Caco-2 cell line as a model of the intestinal barrier: influence of cell and culture-related factors on Caco-2 cell functional characteristics. Cell. Biol. Toxicol. 21(1):1-26.
- San Yeoh, B., P. Saha, X. Xiao, V. Singh, and M. Vijay-Kumar. 2017. Enterobactin, a

- metallophore, mitigates the immune responses of macrophages. *J. Immunol.* 198 (Suppl.):121.13.
- Sawatzki, G., F. Hoffmann, and B. Kubanek. 1983. Acute iron overload in mice: pathogenesis of *Salmonella typhimurium* infection. *Infect. Immun.* 39:659-665.
- Schönfeldt, H., and N. G. Hall. 2011. Determining iron bio-availability with a constant heme iron value. *J. Food. Com. Anal.* 24:738-740.
- Sebastiani, G., and K. Pantopoulos. 2011. Disorders associated with systemic or local iron overload: from pathophysiology to clinical practice. *Metallomics.* 3:971-986.
- Seo, S., H. Lee, H. Ahn, and I. Paik. 2008. The Effect of Dietary Supplementation of Fe-methionine Chelate and FeSO₄ on the Iron Content of Broiler Meat. *Asian. Austr. J. Anim. Sci.* 21:103.
- Shayeghi, M., G. O. Latunde-Dada, J. S. Oakhill, A. H. Laftah, K. Takeuchi, N. Halliday, Y. Khan, A. Warley, F. E. McCann, and R. C. Hider. 2005. Identification of an intestinal heme transporter. *Cell.* 122:789-801.
- Sherman, A. R. 1992. Zinc, copper, and iron nutriture and immunity. *J. Nutr.* 122:604-609.
- Shi, J., and J. E. Casanova. 2006. Invasion of host cells by *Salmonella typhimurium* requires focal adhesion kinase and p130Cas. *Mol. Biol. Cell.* 17:4698-4708.
- Shi, R., D. Liu, J. Sun, Y. Jia, and P. Zhang. 2015. Effect of replacing dietary FeSO₄ with equal Fe-levelled iron glycine chelate on broiler chickens. *Czech J. Anim. Sci.* 60:233-239.
- Smith, D., J. Cason, and M. Berrang. 2005. Effect of fecal contamination and cross-contamination on numbers of coliform, *Escherichia coli*, *Campylobacter*, and *Salmonella* on immersion-chilled broiler carcasses. *J. Food. Prot.* 68:1340-1345.
- Shinde, P.L., Ingale, S.L., Choi, J.Y., Kim, J.S., Pak, S.I. and Chae, B.J. 2011. Efficiency of inorganic and organic iron sources under iron depleted conditions in broilers.

Brit. Poult. Sci. 52(5), 578-583.

Spears, J., W. Schoenherr, E. Kegley, W. Flowers, and H. Alhunsen. 1992. Efficacy of iron methionine as a source of iron for nursing pigs. *J. Anim. Sci.* 70:243.

Stevenson, B., E. E. Wyckoff, and S. M. Payne. 2016. *Vibrio cholerae* FeoA, FeoB, and FeoC interact to form a complex. *J. Bacteriol.* 198:1160-1170.

Stiernagle, T. 2006. Maintenance of *C. elegans*. *WormBook*, ed. The *C. elegans* Research Community.

Stintzi, A., C. Barnes, J. Xu, and K. N. Raymond. 2000. Microbial iron transport via a siderophore shuttle: a membrane ion transport paradigm. *Proc. Natl. Acad. Sci.* 97:10691-10696.

Sturkie, P. D. 2012. *Avian physiology*. Springer Science and Business Media, Boston, MA.

Sun, J., D. Liu, and R. Shi. 2015. Supplemental dietary iron glycine modifies growth, immune function, and antioxidant enzyme activities in broiler chickens. *Livest. Sci.* 176:129-134.

Srinivasan, S., J. Annaraj, and P. Athappan. 2005. Spectral and redox studies on mixed ligand complexes of cobalt (III) phenanthroline/bipyridyl and benzoylhydrazones, their DNA binding and antimicrobial activity. *J. Inorg. Biochem.* 99(3):876-882.

Takeuchi, A. 1967. Electron microscope studies of experimental *Salmonella* infection. I. Penetration into the intestinal epithelium by *Salmonella typhimurium*. *Am. J. Pathol.* 50:109.

Tako, E., M. Rutzke, and R. Glahn. 2010. Using the domestic chicken (*Gallus gallus*) as an in vivo model for iron bioavailability. *Poult. Sci.* 89:514-521.

Tan, M.W., Mahajan-Miklos, S. and Ausubel, F.M. 1999. Killing of *Caenorhabditis elegans* by *Pseudomonas aeruginosa* used to model mammalian bacterial

- pathogenesis. Proc. Natl. Acad. Sci. 96:715-720.
- Taschetto, D., S. L. Viera, C. R. Angel, C. Stefanello, L. Kindlein, M. A. Ebbing, and C. T. Simoes. 2017. Iron requirements of broiler breeder hens. Poultry Sci. 96:3920-3927.
- Teucher, Olivares, and Cori. 2004. Enhancers of iron absorption: ascorbic acid and other organic acids. Int. J. Vitam. Nutr. Res. 74(6):403-419.
- Thiennimitr, P., S. E. Winter, M. G. Winter, M. N. Xavier, V. Tolstikov, D. L. Huseby, T. Sterzenbach, R. M. Tsois, J. R. Roth, and A. J. Bäumlér. 2011. Intestinal inflammation allows *Salmonella* to use ethanolamine to compete with the microbiota. Proc. Natl. Acad. Sci. 108:17480-17485.
- Touati, D. 2000. Iron and oxidative stress in bacteria. Arch. Biochem. Biophys. 373:1-6.
- Tsois, R. M., A. J. Bäumlér, F. Heffron, and I. Stojiljkovic. 1996. Contribution of TonB- and Feo-mediated iron uptake to growth of *Salmonella typhimurium* in the mouse. Infect. Immun. 64(11):4549-4556.
- Turner, J. R. 2009. Intestinal mucosal barrier function in health and disease. Nat. Rev. Immunol. 9(11):799.
- Uchiya, K.-i., and T. Nikai. 2012. *Salmonella*: strategies for survival. Toxin. Rev. 31:1-10.
- Van Asbeck, B., J. Marcelis, J. Marx, A. Struyvenberg, J. Van Kats, and J. Verhoef. 1983. Inhibition of bacterial multiplication by the iron chelator deferoxamine: potentiating effect of ascorbic acid. Eur. J. Clin. Microbiol. Infect. Dis. 2:426-431.
- Van Boeckel, T.P., Brower, C., Gilbert, M., Grenfell, B.T., Levin, S.A., Robinson, T.P., Teillant, A. and Laxminarayan, R. 2015. Global trends in antimicrobial use in

- food animals. Proc. Natl. Acad. Sci. 112(18). 5649-5654.
- Vieira, S. L. 2008. Chelated minerals for poultry. Rev. Bras. Cienc. Avic. 10:73-79.
- Visca, P., E. Filetici, M. Anastasio, C. Vetriani, M. Fantasia, and N. Orsi. 1991. Siderophore production by *Salmonella* species isolated from different sources. FEMS Microbiol. Lett. 79:225-231.
- Wang, C., J. Wang, J. Gong, H. Yu, J. C. Pacan, Z. Niu, W. Si, and P. M. Sabour. 2011. Use of *Caenorhabditis elegans* for preselecting *Lactobacillus* isolates to control *Salmonella* Typhimurium. J. Food. Prot. 74(1):86-93.
- Wang, J., and K. Pantopoulos. 2011. Regulation of cellular iron metabolism. Biochem. J. 434:365-381.
- Weinberg, E. D. 1984. Iron withholding: a defense against infection and neoplasia. Physiol. Rev. 64:65-102.
- Weinberg, E. D. 1992. Iron depletion: a defense against intracellular infection and neoplasia. Life Sci. 50:1289-1297.
- Wheby, M. S. 1970. Site of iron absorption in man. Eur. J. Hematol. 7:56-62.
- Willemetz, A., S. Beatty, E. Richer, A. Rubio, A. Auriac, R. J. Milkereit, O. Thibaudeau, S. Vaulont, D. Malo, and F. Canonne-Hergaux. 2017. iron-and hepcidin-independent Downregulation of the iron exporter Ferroportin in Macrophages during *Salmonella* infection. Front. Immunol. 8:498-509.
- Williams, P., W. Rabsch, U. Methner, W. Voigt, H. Tschäpe, and R. Reissbrodt. 2006. Catecholate receptor proteins in *Salmonella enterica*: role in virulence and implications for vaccine development. Vaccine. 24(18):3840-3844.
- Winter, S. E., P. Thiennimitr, M. G. Winter, B. P. Butler, D. L. Huseby, R. W. Crawford, J. M. Russell, C. L. Bevins, L. G. Adams, and R. M. Tsolis. 2010. Gut

- inflammation provides a respiratory electron acceptor for *Salmonella*. *Nature*. 467:426.
- Wood, W. B. 1988. The nematode *Caenorhabditis elegans*. Cold Spring Harbor Press, New York, NJ.
- Woodward, M. J., G. Gettinby, M. F. Breslin, J. D. Corkish, and S. Houghton. 2002. The efficacy of Salenvac, a *Salmonella enterica* ssp. *Enterica* serotype Enteritidis iron-restricted bacterin vaccine, in laying chickens. *Avian. Pathol.* 31:383–392.
- Woodward, M. J., G. Gettinby, M. F. Breslin, J. D. Corkish, and S. Houghton. 2010. The efficacy of Salenvac, a *Salmonella enterica* subsp. *Enterica* serotype Enteritidis iron-restricted bacterin vaccine, in laying chickens. *Avian. Pathol.* 31:383-392.
- Wooldridge, K. G., and P. H. Williams. 1993. Iron uptake mechanisms of pathogenic bacteria. *FEMS Microbiol. Rev.* 12:325-348.
- Wrighting, D. M., and N. C. Andrews. 2006. Interleukin-6 induces hepcidin expression through STAT3. *Blood.* 108:3204-3209.
- Xiao, X., B. S. Yeoh, and M. Vijay-Kumar. 2017. Lipocalin 2, an emerging player in iron homeostasis and inflammation. *Annu. Rev. Nutr.* 37:103-130.
- Yang, X., Brisbin, J., Yu, H., Wang, Q., Yin, F., Zhang, Y., Sabour, P., Sharif, S. and Gong, J. 2014. Selected lactic acid-producing bacterial isolates with the capacity to reduce *Salmonella* translocation and virulence gene expression in chickens. *PLoS One.* 9(4), e93022.
- Yang, C., Chowdhury, M.A., Huo, Y. and Gong, J. 2015. Phytogetic compounds as alternatives to in-feed antibiotics: potentials and challenges in application. *Pathogens.* 4(1), 137-156.

- Yeung, C. K., R. P. Glahn, and D. D. Miller. 2005. Inhibition of iron uptake from iron salts and chelates by divalent metal cations in intestinal epithelial cells. *J. Agric. Food. Chem.* 53(1):132-136.
- Yu, B., W.-J. Huang, and P. W.-S. Chiou. 2000. Bioavailability of iron from amino acid complex in weanling pigs. *Anim. Feed Sci. Technol.* 86:39-52.
- Zarate-Bonilla, L. J., P. Portillo, H. Saenz-Suarez, J. Gonzales-Santos, G. E. Barreto-Sampaio, R. A. Poutou-Pinales, A. F. Rey, and J. G. Rey. 2014. Computational modeling and preliminary *iroN*, *fepA*, and *cirA* gene expression in *Salmonella* Enteritidis under iron-deficiency-induced conditions. *Poult. Sci.* 93:221-230.
- Zoller, H., I. Theurl, R. Koch, A. Kaser, and G. Weiss. 2002. Mechanisms of iron mediated regulation of the duodenal iron transporters divalent metal transporter 1 and ferroportin 1. *Blood Cells Mol. Dis.* 29:488-497.
- Zhang, L.Y., L. Lu, L. Y. Zhang, and X. G. Luo. 2016. The chemical characteristics of organic iron sources and their relative bioavailabilities for broilers fed a conventional corn-soybean meal diet. *J. Anim. Sci.* 94: 2378-2396.
- Zhang, L. Y., X. F. Li, X. D. Liao, L. Y. Zhang, L. Lu, X. G. Luo. 2017. Effect of iron source on iron absorption and gene expression of iron transporters in the ligated duodenal loops of broilers. *J. Anim. Sci.* 95: 1587-1597.
- Zhou, M., X. Liu, H. Yu, X. Yin, S.-P. Nie, M.-Y. Xie, W. Chen, and J. Gong. 2018. Cell signaling of *Caenorhabditis elegans* in response to enterotoxigenic *Escherichia coli* infection and *Lactobacillus zeae* protection. *Front. Immunol.* 9
- Zhou, M., Yu, H., Yin, X., Sabour, P.M., Chen, W. and Gong, J. 2014. *Lactobacillus zeae* protects *Caenorhabditis elegans* from enterotoxigenic *Escherichia coli*-caused death by inhibiting enterotoxin gene expression of the pathogen. *PLoS One.* 9(2), e89004.

Zugasti, O., and J. J. Ewbank. 2009. Neuroimmune regulation of antimicrobial peptide expression by a noncanonical TGF- β signaling pathway in *Caenorhabditis elegans* epidermis. *Nat. Immunol.* 10(3):249.