RURAL CANADIAN PRAIRIE INTERGENERATIONAL COHOUSING:
A PLACE FOR INTEGRATING LIVES AND
SUSTAINING CULTURE

By
Vanessa T. Ilg

A Practicum
Submitted to the Faculty of Graduate Studies
In Partial Fulfillment of the Requirements for the Degree of

MASTER OF INTERIOR DESIGN

Department of Interior Design
University of Manitoba
Winnipeg, Manitoba

© Vanessa T. Ilg 2009

UNIVERSITY OF MANITOBA

FACULTY OF GRADUATE STUDIES

COPYRIGHT PERMISSION

RURAL CANADIAN PRAIRIE INTERGENERATIONAL COHOUSING:
A PLACE FOR INTEGRATING LIVES AND
SUSTAINING CULTURE

By

Vanessa T. Ilg

A Thesis/Practicum submitted to the Faculty of Graduate Studies of the
University of Manitoba in partial fulfillment of the requirement of the
degree

Of

MASTER OF INTERIOR DESIGN

Vanessa T. Ilg © 2009

Permission has been granted to the Library of the University of
Manitoba to lend or sell copies of this thesis/practicum, to the
National Library of Canada to microfilm this thesis and to lend or sell
copies of the film, and to University Microfilms Inc. to publish an
abstract of this thesis/practicum.

This reproduction or copy of this thesis has been made available by
authority of the copyright owner solely for the purpose of private
study and research, and may only be reproduced and copied as permitted
by copyright laws or with express written authorization from the
copyright owner.

RURAL CANADIAN PRAIRIE INTERGENERATIONAL COHOUSING:
A PLACE FOR INTEGRATING LIVES AND
SUSTAINING CULTURE

By
Vanessa T. Ilg

Committee Members

Dr. Mary Anne Beecher - Advisor
(Department of Interior Design)
Dr. Richard Milgrom - Internal Examiner
(Department of City Planning)
Dr. Geoffrey Smith - External Examiner
(Department of Environment and Geography)

University of Manitoba

2009

© Vanessa T. Ilg 2009

There have been several individuals that have contributed to the completion of this practicum that I owe much gratitude.

First is to my committee members, Dr. Mary Anne Beecher, Dr. Richard Milgrom and Dr. Geoffrey Smith for your consistent dedication, time, enthusiasm, expertise, guidance and advice. I could not have asked for better support to help me through this project. Thank-you.

To the University of Manitoba Graduate Fellowship and the Fridrik Kristjansson Scholarship for their generous contributions through my Masters degree.

To the city board members of Melville, especially Tyrone Mogenson, for your time and aid in retrieving required documents, images and information to make this project possible.

To various other students and staff for always being willing to help or give advise, or just lend an ear.

And, of course, a very special thanks to all of my family and friends and their endless support, patience and love.

Thank-you to you all.

The interior design practicum establishes an awareness of the vastly decreasing population in Canada's rural regions, specifically within the Prairie Provinces, due to a socially increased concentration on the development of urban centers. The project also brings attention to a progressive focus on privatization, isolation and segregation in today's society. Through the research, analysis and design conducted, the practicum demonstrates one possible alternative to seclusion issues fostered in detached living found throughout rural Canadian regions today that better cater to their demographics and may entice populace to remain or move to these rural areas. With a focus on continuity, the consistent existence of historical and cultural preservation over time while progressing and evolving with contemporary innovations and ideas, the practicum's underlying basis is to acknowledge the importance of rural, cultural and historical continuity through an alternative intergenerational cohousing model. By following ideas in the development of a suitable 'home' environment, integrated living strategies, critical regionalist design and adaptive reuse techniques, the rural cohousing project develops a solution that combines all three continuity components mentioned and promotes regional identity, community-oriented living and cross-age learning and networking.

Table of Contents

	iii
<i>Acknowledgements</i>	<u>i</u>
<i>Abstract</i>	<u>ii</u>
<i>Chapter 1 - Introduction</i>	1
1.1 ■ Rural Canadian Decline	1
1.2 ■ The Project	<u>3</u>
<i>Chapter 2 - Context</i>	4
2.1 ■ Evolution of Detachment in Domestic Space in Canada's West	4
2.2 ■ Issues in Detached Housing	8
2.3 ■ The Changing Demographic	8
2.3.1 ■ Older Adults	9
2.3.2 ■ Single Parents	10
2.3.3 ■ Young Adults	10
2.4 ■ Ageism	11
2.5 ■ Economical Shift	11
2.6 ■ Results	<u>12</u>
<i>Chapter 3 - The Site</i>	14
3.1 ■ The Town	14
3.2 ■ The Locality	15
3.3 ■ The Building	<u>15</u>
<i>Chapter 4 - Issues and Insights</i>	17
4.1 ■ Home	17
4.1.1 ■ What is 'Home'?	18
4.1.2 ■ Home as Connection and Symbol of Individual and Cultural Identity	19
4.1.3 ■ Habitus in the Home	21
4.2 ■ Integrated Living	23
4.2.1 ■ Twenty-First Century Segregation and Isolation	24
4.2.2 ■ Movement Towards Social Integration	27
4.2.3 ■ Cohousing and Cultural Continuity	29
4.3 ■ Methodology	32
4.3.1 ■ Regionalism: Design of Resistance	33
4.3.2 ■ Traditional Use of the Locale	34
4.3.3 ■ Technological Innovation	41
4.3.4 ■ Adaptable Reuse: Intervention	42

4.4 ■ Wrap up	<u>43</u>
<i>Chapter 5 - Inspiration and Applications</i>	44
5.1 ■ Cohousing	44
5.2 ■ Intergenerational Multi-Resident Living	47
5.3 ■ Critical Regionalism	<u>50</u>
<i>Chapter 6 - Program</i>	54
6.1 ■ Existing Site and Building Analysis	54
6.1.1 ■ Contextual Analysis	54
6.1.2 ■ Site Analysis	55
6.1.3 ■ Building Analysis	59
6.2 ■ User Profiles	61
6.3 ■ Programming	63
6.3.1 ■ Program	63
6.3.2 ■ Spatial Adjacencies	65
6.3.3 ■ Functional, Technological and Spatial Requirements	65
6.3.4 ■ Aesthetic Concept	66
6.4 ■ Building Code Review	67
6.5 ■ Design Guidelines	70
6.5.1 ■ A Home for all Ages and Abilities	71
6.5.2 ■ Networking	72
6.5.3 ■ Identity	73
6.5.4 ■ Intervention	<u>74</u>
<i>Chapter 7 - Design Drawings</i>	75
7.1 ■ Melville Cohousing	75
7.1.1 ■ Site and Exterior	75
7.1.2 ■ Interior Planning	86
7.2 ■ Suite Drawings	96
7.2.1 ■ Formal Drawings	96
7.2.2 ■ Furnishing and Finishes	98
7.2.3 ■ Perspectives	113
7.3 ■ Gaming Room Drawings	116
7.3.1 ■ Formal Drawings	116
7.3.2 ■ Furnishing and Finishes	117
7.3.3 ■ Perspectives	120

7.4 ■ Gym Drawings	121
7.4.1 ■ Formal Drawings	121
7.4.2 ■ Furnishing and Finishes	122
7.4.3 ■ Perspectives	124
7.5 ■ Exercise Space Drawings	125
7.5.1 ■ Formal Drawings	125
7.5.2 ■ Furnishing and Finishes	126
7.5.3 ■ Perspectives	128
7.6 ■ Halls/Reading and Computer Space/Multi-Purpose Seating Drawings	129
7.6.1 ■ Formal Drawings	129
7.6.2 ■ Furnishing and Finishes	131
7.6.3 ■ Perspectives	134
7.7 ■ Communal Dining Drawings	136
7.7.1 ■ Formal Drawings	136
7.7.2 ■ Furnishing and Finishes	138
7.7.3 ■ Perspectives	147
7.8 ■ Communal Dining Drawings	149
7.8.1 ■ Formal Drawings	149
7.8.2 ■ Furnishing and Finishes	150
7.8.3 ■ Perspectives	<u>153</u>
<i>Conclusion</i>	<u>155</u>
<i>References</i>	<u>157</u>
<i>Appendices</i>	162
<i>Appendix A - Functional, Technological and Spatial Requirements</i>	163
<i>Appendix B - Illuminance Categories and Illuminance Values for Interior Activities by the Illuminating Engineering Society of North America</i>	179
<i>Appendix C - Image Copyright Consent</i>	185

Introduction

1.1 ■ Rural Canadian Decline

Today's Canadian society is in a state of rapid development and change. Rising support toward technological progression is initiating evolutions and shifts throughout various societal sectors. With this intensifying focus on technological innovations and advancements in building, business, recreation and communication, Canadian culture, along with the world as a whole, is instigating two major movements. The first is towards en masse concentration of people, wealth and services in city centers, known as urbanization and the second is towards internationally amalgamating economic, technological, sociocultural and political entities, known as globalization (Canizaro, 2007).

This increasing concentration on urbanization and globalization is one contributing factor to today's declining rural Canadian population. According to a Canadian census done in 1851, rural dwellers made up eighty-seven percent of Canada's population. This high concentration of Canadian rural dwellers has decreased to almost one quarter of the original residency, making up twenty percent of the population in 2001, and the number of Canadians in rural locations has declined each following year (see figure 1).

Canadian society began with small rural communities. Rural areas provide significant resources including food, energy and rural landscape amenities such as leisure and recreation space that are

Figure 1
Population Urban and Rural, Canada

	Total population	Urban number	Rural number	Urban % of total population	Rural
Canada					
1851	2,436,297	318,079	2,118,218	13	87
1861	3,229,633	527,220	2,702,413	16	84
1871	3,737,257	722,343	3,014,914	19	81
1881	4,381,256	1,109,507	3,271,749	25	75
1891	4,932,206	1,537,098	3,395,108	31	69
1901	5,418,663	2,023,364	3,395,299	37	63
1911	7,221,662	3,276,812	3,944,850	45	55
1921	8,800,249	4,353,428	4,446,821	49	51
1931	10,376,379	5,572,058	4,804,321	54	46
1941	11,506,665	6,252,416	5,254,239	54	46
1951	14,009,429	8,628,253	5,381,176	62	38
1956	16,080,791	10,714,855	5,365,936	67	33
1961	18,238,247	12,700,390	5,537,857	70	30
1966	20,014,880	14,728,759	5,286,121	74	26
1971	21,568,305	16,410,785	5,157,520	76	24
1976	22,992,595	17,366,970	5,625,625	76	24
1981	24,343,177	18,435,923	5,907,254	76	24
1986	25,309,330	19,352,080	5,957,250	76	24
1991	27,296,856	20,906,872	6,389,984	77	23
1996	28,846,758	22,461,207	6,385,551	78	22
2001	30,007,094	23,908,211	6,098,883	80	20

Source: Statistic Canada from: <http://www40.statcan.gc.ca/101/cst01/demo62a-eng.htm>

supplied to all of society and ensure urban dwellers' quality of life (Jean, 2003). The prairie West is and has always been a prominent contributor to this Canadian culture, society and economy. As President and CEO of the Canada West Foundation, Roger Gibbins states, "the prairie West is the heartland of rural Canada" (Gibbins, 2003, p. 137) and holds a historical significance to Canada's cultural beginnings. The highest rural population found within the prairie regions is in Saskatchewan. This province has a thirty-six percent rural population, but is still losing residency to their urban counterparts (see figure 2).

Coinciding with the focus on urbanization and globalization, the lack of suitable alternative housing is another contributing factor to this rural population decline in Canada. With a rapidly changing demographic and economy, housing in rural regions has experienced a set back in evolving with these shifts. The single-family detached house has been the dominant housing typology in the Canadian rural prairies for a number of years. Mass production of this type of domestic structure became prominent during the great building boom of the decade before World War I (Ward, 1999) and it continues to be the primary housing typology in the rural Canadian markets, making up about seventy-five percent of the housing found there

(Statistics Canada, 2006).

Also, since the urbanization movement has raised demands for the design profession, including interior design, to primarily concentrate its efforts within

Figure 2
Population Urban and Rural, Saskatchewan

	Total population	Urban number	Rural number	Urban % of total population	Rural
Saskatchewan					
1901	91,279	14,266	77,013	16	84
1911	492,432	131,395	361,037	27	73
1921	757,610	218,958	538,652	29	71
1931	921,785	290,905	630,880	32	68
1941	895,992	295,146	600,846	33	67
1951	831,728	252,470	579,258	30	70
1956	880,665	322,003	558,662	37	63
1961	925,181	398,091	527,090	43	57
1966	955,344	468,327	487,017	49	51
1971	926,240	490,630	435,615	53	47
1976	921,325	511,330	409,990	55	45
1981	968,313	563,166	405,147	58	42
1986	1,009,610	620,195	389,415	61	39
1991	988,928	623,397	365,531	63	37
1996	990,237	627,178	363,059	63	37
2001	978,933	629,036	349,897	64	36

Source: Statistic Canada from: <http://www40.statcan.gc.ca/l01/cst01/demo62a-eng.htm>

urban environments, few significant attempts to provide alternative housing for the changing rural demographic have been instigated. The last major movement that brought the interior design sector into such places as prairie towns was during the 1950s and 1960s. During this time, the University of Manitoba Research Centre initiated a program wherein designers redeveloped farm kitchens and utility rooms to better suit the needs of farming families, with particular consideration to the house wife's anthropometric data (Planning Research Centre, University of Manitoba, 1952).

The declining rural population and static housing situation suggests that the implementation of new rural housing types might better meet the needs of rural residents today and entice populace to remain in these communities. With a focus on continuity, integrative living, universal design, regionalism and adaptive reuse, along with incorporating the comfort, the wellbeing and the safety of the inhabitant, interior design professional knowledge, theory and tactics are applied to the proposed project in one attempt to appropriately address these current housing issues in the rural Canadian prairies.

1.2 ■ The Project

Rural, in this proposal, refers to a community of less than five thousand residents that has an economic dependence on a single primary industry. The rural project looks at an intergenerational cohousing alternative to the dominant housing typology in the rural prairies, which caters to their changing demographics while incorporating the private and communal activities that the domestic sphere must support. These spaces include food preparation and eating areas, sleeping quarters, gathering space, media allocation, wash facilities, outdoor amenities and storage for a multitude of diverse objects and devices.

Context

Before establishing an awareness of the current demographic, economic and social evolutions surrounding the housing issues found through the practicum's research, one should first be introduced to the historical context of homes in the western Prairie Provinces.

2.1 ■ Evolution of Detachment in Domestic Space in Canada's West

Homes found throughout Canada's western Prairie Provinces have gone through a transformation from a public, communal focus to an increasing value placed on privatization of domestic space, which is fostered in the ever-present single-family detached house. The first domestic structures that were built in Canada's prairie west were the Plains tipi, log huts, sod houses and shacks (Ward, 1999). Spatial configurations of these structures were significantly homogeneous, being comprised of a single or sometimes double room layout, but each carried a unique character that spoke of the specific homebuilder, their techniques and origins, along with the specific surrounding site, the available materials and climatic allowances. With small, open plans the spaces in these dwellings promoted social gathering and strong family and communal ties through ensuring a high level of interaction amongst their inhabitants along with any visitors to the home.

Also, there have been some significant historical examples of rural Canadian prairie communal living amongst early settlers like the Hutterite people. These individuals, who are primarily located in Canada's rural prairie regions, live in small farm communities known as colonies, where an average of thirteen families live with a population of about ninety people (Peter, 1987). The strong value placed by the Hutterites on communal-living and a shared self-sufficiency

amongst all members of the community, which led to establishment of close-knit village-type settlements, contributed to this groups' survival over many centuries (Low, 1964). This dedication to helping and sustaining everyone in the colony reveals a life that is not concerned with self-centeredness and privatized experience, but rather supports the sharing of skills, knowledge and experience in a way that encourages the passing down and continuity of their culture and history throughout the years. With the Hutterites' social value on community, communal housing has historically been their way of life. Traditionally, all individuals belonging to a single colony live in one house with several units or two or three homes located side by side split into four units on the colony (Stahl, 2003). And, although today there are more separate but still closely built row house typologies found on Hutterite colonies, many of these households still include large extended families that support multi-generational living (Peter, 1987). Whether the communal living situation is in the multi-unit housing or more separate homes, a closely-held and strictly practiced value on communal dining, kitchen, recreation and meeting spaces and buildings remain present amongst colonies to maintain close community-oriented principles and ties (Stahl, 2003). As one woman living on one of these colonies stated, they live with much conviction to the biblical quote 'love thy neighbor' and there is no better way to honor this value than by living, working and just simply being together everyday (Low, 1964).

Focus on small open homes and multi-generational living only lasted for a short period after the initial west settlement though, with the exception of the previously mentioned Hutterite people. Following development in Canada's established east, standardised single-family detached dwellings became cheap and easy to construct and

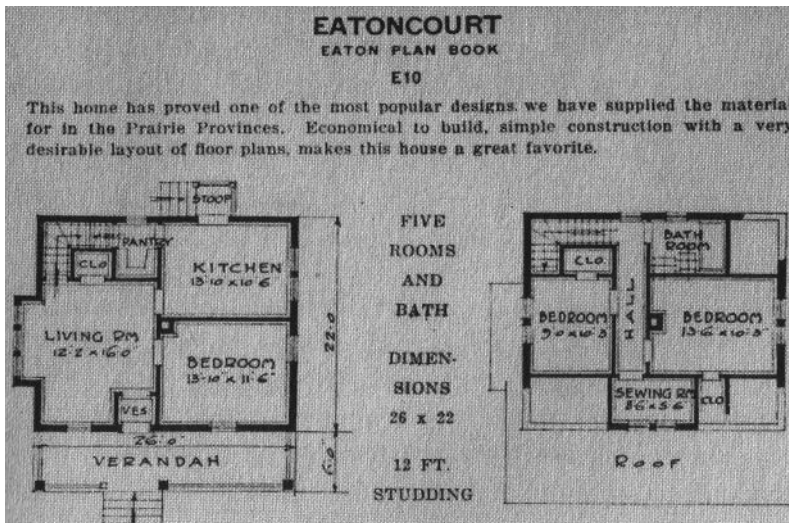

Figure 3 - Plan for one-and-a-half storey house popular in the Prairie Provinces

California Style Bungalow Plan, Canada 1919

Large inclusive spaces with open plans, minimal corridors and use of built-ins to increase living space

thereby increasingly in demand during the great prewar building boom in the Prairie Provinces (Ward, 1999). The California bungalow style was the most common single-family detached housing typology built throughout the prairie west. The basic footprint of these larger homes still maintained a relatively open plan comprised of large, inclusive spaces (see figure 3). Some of the spaces and features found in this bungalow style are living and dining areas grouped in one or two rooms, corridors kept at a minimum and wide use of built-in features to increase living space. Like the former one or two room home, spaces throughout the bungalow still serve multiple functions. As Peter Ward found in his research on the history of domestic space in Canada, historically the kitchen was not only a space for preparing food, it also acted as an event and gathering space and today "it remains common practice in rural and small town Canada...to entertain close family friends in the kitchen" (Ward, 1999, p. 24).

The fireplace or hearth also plays a significant role in the history of Canadian dwellings, one that symbolizes togetherness and gathering and that persists to the present day Canadian home, "long after it could claim much utility" (Ward, 1999, p. 66). Until central

heating and electric light were introduced to Canadian homes in the late nineteenth century, the fireplace was the home's source of heat, light and cooking facility (Ward, 1999) through the long harsh Canadian winters, especially experienced in the prairies. Due to this prominent presence, the hearth was and continues to act as a metaphorical focal point of family life and sociability in many Canadian homes.

Verandahs were also widely used features particularly found in the California style bungalow built in western Canada during the pre-war building boom. These features maintained a communal focus that bridged the privacy of the indoors with the publicity of the outdoors; between the life of the home and that of the community (Ward, 1999). After the war, these elements that combined private and public life were replaced by a simple set of stairs leading to a small covered landing just outside the front door (Ward, 1999), contributing to a turn towards introversion of the present single-family detached houses built today.

Also, single-family detached dwellings built in the last couple of decades in Canada's rural west follow larger city centers' suburban typologies that incorporate more segregated rooms, large double car garages on the front and private gardens in the back (Ward, 1999). All of these current housing features reveal the progression of an increasingly introverted, privatized focus in domestic life. This focus on privatization does not support interaction amongst a households members or the 'neighborliness' of socializing within the surrounding community, which was once prominently fostered through 'small town life' and some of the previously mentioned domestic building elements found throughout Canada's rural prairies.

2.2 ■ Issues in Detached Housing

As mentioned, the single-family detached house is the dominant housing typology within the Canadian rural prairie regions. With the changing demographics found throughout these regions today, these specific structures are found to not only be exclusive and introverted, but also inappropriately sized and too costly. Researcher Jennifer de Peuter (2005) recorded that almost eleven percent of all rural and small town Saskatchewan residents spend thirty percent or more of their income on housing costs. She also found that housing costs in some of these rural areas increased almost thirteen percent between 1991 and 2001, making the housing advantage once found within most rural zones nonexistent (De Peuter, 2005).

Also, with the focus on urbanization and the lack of concentration and development in rural dwellings, few suitable alternatives for housing have emerged in the rural Canadian prairies. In support for establishing updated multi-resident housing models that cater to the changing demographics within rural Canada, a case study done by David Bruce (2003) on Canadian rural housing found that very little multi-resident housing choices exist, either rental or owned, within rural areas studied throughout the country. The case study also revealed that the multi-resident options that do exist are characterized by low vacancies due to poor conditions, and high operating costs (Bruce, 2003).

2.3 ■ The Changing Demographic

Family structures are changing and reducing in size today, which has initiated concerns with the size appropriateness of the single-family detached house in correspondence to these demographic changes, especially within rural regions that do not have available alterna-

tives. Following this shift in family structure size, three main demographic groups are emerging in the rural prairies that are highly affected by the limited housing options available. These groups include older adults, single-parent households and single young adults.

2.3.1 ■ Older Adults

The largest group of individuals affected by the lack of suitable housing alternatives is the older adult population. With the increasing number of aging baby boomers reaching their later years in life, the older adult demographic is rising in the Canadian rural regions today, with a nineteen percent increase of rural seniors between 1996 and 2006 (Rothwell, 2008). With a 15.4 percentage, Saskatchewan is recorded to have the highest population aged sixty-five years and older throughout Canada (Statistics Canada, 2006). Specifically looking at the chosen region of Melville, Saskatchewan, a 2006 census recorded a thirty-three percent population aged sixty plus with a median age of the total population being around forty-seven in this region (Statistics Canada, 2006), which means this aging baby boomer cohort will continue to increase this median age in the upcoming years. David Bruce (2003) also recorded in his study on rural Canadian housing that the aging population is more pronounced in rural Canada and that a higher number of older citizens are moving from urban to rural communities. Also, as Heywood, Oldman and Means (2002) found in their research on housing and home in later life, the driving forces behind mandatory moves from single-family detached housing in a person's later years are due to both physical and financial decline and maintenance issues of these large, demanding dwelling typologies. With the shift in a more pronounced aging demographic, a change in housing requirements and a desire to accommodate them is essential to sustain these rural regions.

2.3.2 ■ Single Parents

The second demographic group that is largely seen throughout rural Canada today is the single parent household. These smaller families are on the rise in both urban and rural societies throughout the country. Findings in a recent rural Canadian census suggest that the average number of persons per household in rural Saskatchewan is 2.4 and Melville's specific single-parent households made up about thirty-three percent of the total household numbers recorded with children in the town in 2006 (Statistics Canada, 2006). Many single parents also fall into a lower financial bracket due to a reduced family income along with many experiencing inadequate access to public and social resources (Ahrentzen, 1989). With these issues and the cutbacks in family sizes, housing that accommodates these nontraditional households is suggested.

2.3.3 ■ Young Adults

In addition to the senior and single parent occupancy, another influential demographic group in the rural prairies is the younger single or duo dweller population. The presence of this demographic group strongly affects the future outlook of these rural areas since these residents will be the main contributors to the economy and work force once the baby boomer population retires. David Bruce's (2003) research on rural housing issues in Canada revealed a high out-migration of young adults from rural communities in favor for urban centers where there are more housing and job opportunities. From teachers and healthcare professionals who are serving a working term in these areas, to single residents moving away from home after high school, this demographic requires adequate housing that suits its specific lifestyle, thereby influencing young adults to remain living in rural communities.

2.4 ■ Ageism

Another issue pertaining to these different demographic groups is ageism. Differential social gaps between generations are broadening and contributing to segregation, marginalization and intolerance amongst each age group. As a result of this gap, prejudices and discrimination that are targeted towards each age group, known as ageism, have become principle concerns (McPherson and Wister, 2008). Multi-resident living accommodations that integrate rather than segregate different age groups and individuals, like the isolation fostered in single-family detached housing, would promote physical and personal interaction, bonding and learning amongst the residents in attempts to decrease these age gaps.

2.5 ■ Economical Shift

Along with demographic changes, Canada's increasing focus on urbanization and globalization has initiated economic changes that contribute to the decline of Canada's rural sectors. David Bruce (2003) discusses three categories of Canadian rural regions in association to urban proximity that have been determining factors in the housing quality and overall survival of the community in his paper *Housing Needs of Low-Income People Living in Rural Areas*. These rural typologies are the rural metro-adjacent regions, the non-metro-adjacent regions, which is the category that the chosen site of Melville, Saskatchewan fits under, and the northern and remote regions. Through the study of each category, Bruce (2003) found that rural communities in close proximity to an urban center, the rural metro-adjacent regions, are able to thrive economically from support and trade with the city and are thereby growing faster than more remote rural regions. Jennifer de Peuter (2005) supports this conclusion through her research

wherein she found that rural areas in Saskatchewan that are closer to city centers have the newest and most expensive housing throughout the province's rural and small town sectors. The positive growth and evolution of these regions having newer, more efficient homes also comes with a downfall though. Shelter is becoming less affordable as housing costs rise in the rural metro-adjacent regions, eliminating the affordable housing advantage once found within most rural zones (De Peuter, 2005).

Bruce's (2003) second and third categories for Canadian rurality, the non-metro-adjacent and northern and remote regions, are less prosperous in construction and development than their metro-adjacent counterparts. Most housing found in these areas, according to a sample case study done by Bruce (2003), have high heating and utility costs due to poor insulation. With the high costs, fifteen percent of these households face affordability problems (Statistics Canada, 1996), which is another contributing factor to the out-migration of individuals in the non-metro-adjacent and northern remote regions. These conclusions reveal that the location of the rural population is less likely to occur in these distant, independent communities, causing a loss of small town culture.

2.6 ■ Results

With the gradual downfall and lack of concentration on rural communities in Canada, these areas are losing their distinctiveness and the prominent presence that they once had in the history of the country. These regions, especially the western areas, act as roots and a solid grounding to the increasingly global and urban reign, and help maintain Canada's significant socio-diverse and heterogeneous culture. As professor and specialist in rural development, Bruno Jean points

out, just as protecting bio-diversity has become a universally held value today, with this decreasing rural population, there is a need to also "protect socio-diversity in the human world as one would bio-diversity in the animal and plant world" (Jean, 2003, p. 156). And, according to Roger Gibbins, the prairie West is "the primary battleground for the future of rural Canada" and "if rural Canada falls here, it will fall everywhere" (Gibbins, 2003, p. 137). It is important to acknowledge the need for a movement towards preserving these cultural beginnings.

The design project at hand establishes an awareness of the importance of Canadian rural continuity and preservation through interior design knowledge and application. By proposing an alternative to the static housing situation found within these rural areas, the project addresses and initiates an awareness of the current needs and issues found amongst the changing rural demographic in an attempt to aid in the sustaining of these culturally significant communities.

The Site

As the practicum project incorporates aspects of preserving culture and identity in Canada's rural prairie regions, an introduction to the history of the chosen site becomes integral to establishing a background to the design decisions and theoretical basis of this specific housing project.

3.1 ■ The Town

The general site for the design project is the rural non-metro adjacent region of Melville, Saskatchewan, located in the southeast area of the province (see figure 4). The original inhabitants of the Melville district were the Cree, Salteaux and the Stony Native American groups (Melville History Book Committee, 1983). The district developed into an agricultural settlement in the late nineteenth century with settlers originating from Germany, Poland, Central Europe, the United States and the British Isles (Melville History Book Committee, 1983), and it continues to prosper in the agricultural field, accommo-

dating the head office of the Saskatchewan Crop Insurance Corporation today. Melville grew quickly after initial European settlement, primarily due to the establishment of the Grand Trunk Pacific Railway, which designated Melville as the second divisional point west of Winnipeg on the main line in 1906. It was this significant development of the railway industry that influenced the town's name, after the president of the railway Charles Melville Hays (Melville History Book Committee, 1983). Today Melville has a population of



Figure 4 - Map of Saskatchewan, Canada

approximately 4,500 residents and continues to be prosperous as a railway centre and in the agricultural industries, hence the town's slogans "Melville, the Heart of the West . . . Industry, Prosperity and Education" and "Melville, On the Right Track".

3.2 ■ The Locality

Melville is fortunate to have a high quality and amount of water supply. The district is surrounded by rolling prairie with numerous sloughs and marshes and is wooded with occasional clumps of poplar and pine trees that were used in the vast majority of early building. The town experiences extremes in heat and cold, having long, harsh winters and dry, hot summers. Melville has one of the highest numbers of hours of bright sunshine in North America, exposed to between 5.8 and 6.3 hours per day on average (Environment Canada, 2000). The relatively flat, unsheltered terrain, produces winds most frequently blowing from the west, at sometimes gusting over one hundred kilometers per hour.

3.3 ■ The Building

Within the town, the project will focus on strategies for adaptable reuse and heritage preservation within a culturally significant building that has been abandoned for just over six years, the town's former St. Peter's Hospital (see figures 5-8). The central, original structure was built in 1941 and due to a vast increase in patients from the town itself and surrounding districts, the hospital received north and south additions during the mid- to late- 1960's. The hospital was originally "one of the most modernly constructed, equipped and furnished hospitals in Western Canada" (Melville History Book Committee, 1983, p. 256) and was the first of two hospitals in the province to be fully accredited by the American College of Surgeons, establishing it

as a 'Grade A Hospital'. The two-toned brick building, which includes a seven-acre property with mature landscaping, is located at a reasonable distance from the downtown core, about eight blocks, where a major chain grocery store, post-office, three banks, pharmacy and doctor's office are located. The old hospital is positioned within a family-oriented residential neighborhood and is situated two blocks east of one of the town's park areas and about two blocks northwest of one of the town's three elementary schools (see figure 37). It is three-storeys high and each floor measures approximately 8,500 square feet.



Figure 5
Former St. Peter's Hospital
Melville, Saskatchewan
Hospital Front West Side



Figure 6
Former St. Peter's Hospital
Melville, Saskatchewan
Hospital Back East Side



Figure 7
Former St. Peter's Hospital
Melville, Saskatchewan
Hospital North Side



Figure 8
Former St. Peter's Hospital
Melville, Saskatchewan
Hospital South Side

The research-based design project's underlying focus is on *continuity*. Continuity in regards to the theoretical basis of this project can be described as consistent existence of historical and cultural preservation over time while progressing and evolving with modern innovations and ideas. The three major areas where this continuity is demonstrated in the cohousing project is through its focus on communal living in rural areas which promotes rural continuity, cross-age learning which promotes cross-age relationships and thereby cultural continuity, and critical regionalism and adaptive reuse that promote both historical and cultural continuity. All three of these components and their theoretical foundations are linked and combined through the proposed intergenerational cohousing building and design of a home environment for the targeted user groups. The project incorporates various interdisciplinary issues, theories and tactics, with particular focus on ideas in the composition of 'home,' integrated living, regionalism and adaptive reuse, in order to establish this rural, cultural and historical continuity and constitute an appropriate design resolution that speaks of the specific rural Canadian site, context and demographic chosen.

4.1 ■ Home

As previously discussed, the lack of adequate housing in Canada's rural West seems to be one contributing factor to these regions' declining populations. Since the design project focuses on more appropriate domestic design solutions for the changing demographic in these areas as one possible contributor to rural continuity, what, then, are the characteristics and qualities of a domestic setting that can

establish not only a suitable physical shelter, but also a sense of 'home' and belonging to its residents?

4.1.1 ■ What is 'Home'?

The home. It is a symbol of one's cultural and individual identity and a psychological base and connection to past and present memories and events (Gifford, 2002). Since the mental and physical composition of these environments helps its residents' lives thrive or stagnate, environmental psychologist, Robert Gifford, asserts that "home is the most important place in our lives" (Gifford, 2002, p. 236).

There are several terms that many interchange when speaking of these domestic environments. In this practicum, I will look at three basic constituents of the domestic sphere, these being the household, the house and the home, in order to define and characterize what the concept of establishing a suitable 'home' environment entails. According to Roland Sawatzky's (2005) research, the household is the sense of stability, predictability and comprehensibility that a domestic environment provides for its inhabitants. Through a series of interactions amongst these inhabitants in the household setting, reiterations of basic social divisions and personal identities take place and the architecture that frames these activities is the house. It is these physical and mental aspects that in turn combine to make the home. As Sawatzky describes this combination, the home is a "unit of architecture and interaction where people normally carry out those functions key to human existence, in an atmosphere of relative safety and predictability" (Sawatzky, 2005, p. 7).

Also, according to environmental psychologist, Robert Gifford (2002), six different dimensions comprise the home environment. These

dimensions are: home as haven, home as order, home as identity, home as connectedness, home as warmth and home as physically suitable. The home as haven protects the inhabitant from life and elements of the outdoors while providing privacy and refuge. The home as a base from which the user ventures and returns to, orders his or her existence in the world. The home as a self-expression acknowledges that personalized space becomes a symbol of self and identity. The home also connects the inhabitant to the past, present and future through order and identity, while providing a sense of belonging to a particular family, group, culture, neighborhood or community. Symbolically, home is warmth since it not only provides shelter from the elements, but also provides users with a sense of comfort. Finally, if a home is physically suitable, it provides the actual physical components of shelter and establishes a form and structure for fulfilling the users' psychological needs. With particular consideration to the dimensions of connection and identity, the design project's incorporation of these ideologies of the home environment privileges housing as the foundation of community and the greater, contextual base of relationships and amenities that it potentially can provide to an individual while promoting cultural and self expression.

4.1.2 ■ Home as Connection and Symbol of Individual and Cultural Identity

In order to establish Gifford's dimensions of home as individual and cultural identity along with home as connection, through design, the rural housing project takes a closer look into the creation of culture within a 'home' environment with particular consideration to the selected user groups and site. A common definition of culture is beliefs, customs, practices, and social behaviors of a particular

nation or group of people. Architectural professor, Peter MacKeith, further divulges the definition of culture in his book *Encounters: Architectural Essays*. MacKeith states that culture is a specific community's concept of the world and more so that culture constitutes an "entity of facts and beliefs, history and the present, material realities and mental conditions" (MacKeith, 2005, p. 266). Since culture is learned and assimilated over a person's lifetime and influenced by members both inside and outside of that cultural group, cultural knowledge is therefore "produced, reproduced and circulated through active relational involvement" (Sawatzky, 2005, p. 10) and interaction between the members of a specific culture. Sociologist, Pierre Bourdieu, furthers the assimilation of cultural knowledge as the process of 'habitus.' Habitus, according to Bourdieu, is a set of shared dispositions that generates and directs a person's practices and perceptions. These dispositions are created through daily experience within a historical context and are initially established in the home setting (Sawatzky, 2005).

Since the domestic sphere is the setting in which much daily practice takes place and it is also the initial place in an individual's life where they are subjected to relational involvement and interaction amongst members of the household and the greater surrounding community, the home becomes the fostering ground of the previously mentioned habitus and cultural development. In his study on domestic space and its relationship to culture, Roland Sawatzky points out that "the human learns, in daily practice, the structures by which to skillfully relate to the world" (Sawatzky, 2005, p. 10). He also accredits the home environment, and all of its mental and physical components mentioned, to asserting cultural identity and providing the opportunity to develop networks of various social relationships, both

of which are carried through and continue to evolve throughout an individual's lifetime, with a continual influence from their early domestic experiences. As Sawatzky concludes, it is these integral domestic environments that structure and reflect family and community values and act as stable material devices in society that may reflect the whole of architectural practices' "importance in securing ethnic and cultural continuity" (Sawatzky, 2005, p. 13).

4.1.3 ■ Habitus in the Home

Roland Sawatzky demonstrates how habitus and cultural continuity is established within the home environment through his study *The Control of Space In Mennonite Housebarns of Manitoba*. Based on his research, the author suggests that "the Mennonite housebarn, including its floor plan and its orientation to the village layout, was used as a structuring device for the reinforcement of Mennonite habitus" (Sawatzky, 2005, p. 29) as it structured social values and the pressures between the economic household and community demands. Early Mennonite settlements acted like one solid unit of social and economic organization and revolved around an emphasis on self-sufficiency for that entire unit, where goods and services were shared and distributed throughout the community. All members of the community shared cultural views on religion, social control and labor, where each individual dwelling was expected to contribute to providing for the entire settlement (Sawatzky, 2005). The original housebarn included three different functions under one roof; the dwelling, the workroom and the byre for cattle (see figure 9). Having all three programs in one built environment reflected the strong emphasis on the complete integration of work and domesticity that was part of the culture of everyday life throughout these communities. Also, the rooms in the housebarn all



Figure 9 - An early Mennonite housebarn located in the Canadian prairies

Hamm Housebarn, Neuberghal, Manitoba
1901

The combination of three programs in one built environment reflected cultural values of the Mennonite

attached directly and were non-personalized and multifunctional, reflecting the egalitarian value based on community rather than on the individual of the Mennonite culture.

Communal views on social control were also practiced and reflected through spatial divisions within these home environments. Age categories and authority were enforced through manipulation of space and restricted access of certain rooms. The living room, for instance, was deeply associated with the parents by presenting their belongings and representing parental dominance and control (Sawatzky, 2005). These intergenerational households also elevated the social status of the elderly by giving the best room in the house to them (Sawatzky, 2005). Also, orienting the housebarns towards the main street facing each other reinforced the focus on strong communal ties by promoting everyday interaction and surveillance amongst all members of the community.

Like the habitus created in the Mennonite housebarn, early rural Canadian domestic environments placed cultural value on extroverted and community-orientated living. Several elements, like the veranda, large open spaces and central hearth, fostered a sense of togetherness and invoked neighborly sociability, promoting the inhabitants to develop strong social networks inside as well as outside of the personal dwelling. As in suburban developments, today's rural Canadian dwellings turn their backs on public spaces in favor of more specialized

private spaces, all contained within large fences. As a result, "the social life of transitional spaces between the home and the road is eroding" (Ward, 1999, p. 158) and the once community-oriented, cooperative association in small town culture is vanishing with it (Ward, 1999). The age integrated cohousing model being proposed reflects the habitus and cultural identity of early domestic building in rural areas in order to preserve and reinitiate a movement back towards a focus on community living and instilling a more sociably integrated way of life, one that is distanced from the current detached living promoted by freestanding housing and the isolating technologies in them that foster impersonal ties to the whole of society (Wentling, 1995). In turn, the cohousing model supports cultural continuity by looking at new ways to bring back community-oriented living while working towards fulfilling the ideologies of the constituents of a 'home' mentioned for the intended inhabitants, thereby encouraging the populace to remain or return to these rural areas and work towards rural continuity.

4.2 ■ Integrated Living

Prairie towns such as Melville often have unused large-scale buildings such as schools, hotels and hospitals that could benefit from re-purposing. Using such buildings as a model for housing would suggest moving away from individual freestanding dwellings and issues in segregation that they foster to more integrated forms of accommodations. Since the design project focuses on developing a community-oriented, age-integrated, multi-resident housing model, what, then, are the key qualities of a successful intergenerational cohousing design and what are the advantages of this specific approach?

4.2.1 ■ Twenty-First Century Segregation and Isolation

With an increased focus on urbanization, globalization and technological advancements, there is a growing perception of rising isolation and societal self-centeredness amongst individuals today. Much of this isolation and introversion derives from contemporary Western societies' tendencies to progressively segregate individuals by age, race and gender along with increasing value placed on privatization of experience and living (Newman, Ward, Smith, Wilson & McCrea, 1997). With an age-integrated focus, this cohousing project looks specifically at North American society's tendency to segregate people by chronological age in three social dimensions: institutional, spatial, and cultural; and the effects of not only having the family as the sole surviving age-integrated institution, but also the effects of the trend towards less extended family living today (Newman, Ward, Smith, Wilson & McCrea, 1997).

There has been significant research done, especially in the last couple of decades, on the effects and importance of age-integrated interaction in today's increasingly segregated society, specifically amongst related individuals. This practicum focuses on more general, inclusive benefits and products of intergenerational relations extended beyond the family, specifically looking at research done by Gunhild O. Hagestand and Peter Uhlenberg on age segregation today. These sociological researchers discuss concerns in social conflict brought forth by the three dimensions of age segregation: institutional, spatial, and cultural; in their paper *Should We Be Concerned About Age Segregation?* The authors describe institutional age segregation as the inclusion of chronological age as a determining factor in a person's eligibility to participate in a particular social institution (Hagestad & Uhlenberg, 2006). Two common settings of institutional age

segregation are schools and work environments, along with various others. Spatial age segregation occurs, according to the same article, when people of various ages are never occupying the same space and is fostered through institutional age segregation (Hagestad & Uhlenberg, 2006). This social segregation prohibits inhabitants to engage in face-to-face interaction with various age groups in both domestic and public spaces throughout society. Cultural age segregation is the product of both institutional and spatial separation by age (Hagestad & Uhlenberg, 2006). Without the exposure and interaction amongst various age groups, terms like *youth culture* develop to describe the difference in world views, language, dress, food and music preference that are linked to a distinct lifestyle that further separates such age groups.

With a wide array of institutional arrangements that separate all age categories, individuals have limited opportunity to develop cross-age relationships over their lives (Hagestad & Uhlenberg, 2006). This lack of opportunity for age-integrated relationships therein progresses intolerance amongst the different age groups and results in the previously discussed subject matter of ageism, the development of beliefs or behaviors based on a person's chronological age, consequently fostering stereotyping and discrimination between each group.

This social segregation takes place in domestic environments as well as public places and prohibits individuals from establishing and maintaining strong social networks in their lives. Networks, according to Hagestad and Uhlenberg (2006), are key to integrate individuals of any age into the larger society and help in developing perceptions of the world and shaping and sustaining identities. Age homogeneity of such social networks, which is fostered through institutional, spatial and cultural age segregation along with a lack of communal

arenas that support steady communication amongst various ages, perpetuates the segregation-ageism cycle and makes the building of personal knowledge of one another complicated for members of all different age groups (Hagestad & Uhlenberg, 2006). This unsupportive nature to cross-age ties and knowledge can ultimately have a wide range of possible consequences on all individuals throughout their life course.

The single-family detached home found throughout the rural Canadian prairies along with age-segregated housing are two of North America's building typologies that contribute to implementing segregation and loss of social networks, especially amongst the project's three targeted user groups, which negatively affects the inhabitants and the community at large. The older adult population and children are above the most significantly affected user groups. Findings by sociologist, Dale J. Jaffe, indicate that the aging population experience pains of loneliness and isolation when singly dwelling in a single-family detached house (Jaffe, 1989). Interviews also revealed that these individuals crave companionship (1989) due to a loss of social networks after the loss of a spouse or as personal mobility deteriorates. Also, according to studies done, those older adults whose close relationships are restricted to people in the same age cohort are vulnerable to the loss of social support and prone to suffer from depression and loneliness in the later years of their lives (Hagestad & Uhlenberg). Anthropologist Margaret Mead suggests that those older citizens who are not socialized by younger members on much of the knowledge and technology needed to master everyday life become *immigrants in time* (Hagestad & Uhlenberg) and unable to take advantage of many modern developments.

Children are also consequently affected by the loss of social networks and knowledge fostered through public and domestic age

segregation. Separating the young from observing adults in both social and domestic settings through age specified spaces deprives them of acquiring appropriate knowledge and social skills that will be needed in their early and later adult lives (Hagestad & Uhlenberg, 2006). This separation also increases adults' intolerance and lack of understanding of children by blocking them from being socialized by younger age groups (Hagestad & Uhlenberg, 2006), leading to frustrating interactions amongst the young, mid- and old aged. Also, segregating youth in various societal sectors prevents the young from growing up with an awareness of history and cultural heritage that could be provided from everyday interaction with the older adult population. In this sense, Hagestad and Uhlenberg (2006) conclude that age segregation deprives both young and old of essential teaching and learning experiences that could be provided from one another, and emphasizes through their research the necessity for intergenerational learning on positive social development and maintenance. And what better place to start this learning than in what Robert Gifford deems the most influential environment in a person's life, the home.

4.2.2 ■ Movement Towards Social Integration

In response to the consequences brought forth through this discussion on isolation and segregation and need for intergenerational learning, Peter Ebner (2007) introduces his take on 'integrated living' as a dynamic model where different groups of residents are encouraged to live together. He regards integrative housing as an improvement to neighborly support between different generations and groups of residents with different needs, which addresses the previous issues on segregation and ageism. With a focus on integrating the three particular user groups in one housing complex, people of

all ages and mobility "can be integrated into everyday life not only through appropriate construction measures in the housing development and in the residences, but rather by mixing various groups" (Ebner, 2007, p. 11).

Chris and Kelly Scotthanson (2005) also advocate the ideology of community-oriented living as a response to the focus on private, independent, isolated, detached living environments of the twenty-first century society. These housing researchers support the fact that homes today, like the dominant single-family detached house found within the rural Canadian prairies, are separated, autonomous and do not support interaction with neighbors, thereby not supporting the connection component of home brought forth by Robert Gifford or the need for the development of strong age-integrated social networks. They also firmly believe that "in today's fast-paced world of competition and lonely individualism, we need a place to belong, a place where we feel safe and supported" (Scotthanson & Scotthanson, 2005, p. 1). Cross-age ties secluded to the family provides individuals with a limiting exposure to the diversity of people of all ages and living with people of various age groups provides diversity of experience for both young and old while building versatile knowledge from multiple viewpoints and perspectives. With the focus on communal integrated living in an intergenerational cohousing model, the project develops a movement back to these ideals of sustainable community living amongst the targeted user groups without sacrificing privacy or control over their own lives. As interdisciplinary researchers, writers and professors Abbott, Carman, Carman and Scarfo conclude, "the qualities of cohousing echo the interdependency previously found in the social proximity of people living a century ago in village and town centers" (Abbott, Carman, Carman & Scarfo, 2009, p. 87) and it presents a

contemporary opportunity for re-creating this sense of place and neighborhood.

4.2.3 ■ Cohousing and Cultural Continuity

In order to achieve these integrated living ideals, a successful cohousing model should have a balance of communal spaces throughout the complex that provides ample opportunity for planned and impromptu meetings and gatherings of all age groups while still allowing for individual units that maintain a sense of privacy and individuality. With the establishment of this balance, the cohousing project provides social, mental and physical benefits to the targeted user groups while promoting cultural continuity by bringing back and sustaining past small town culture oriented around supportive communal living.

First, older adults benefit from the cohousing model's balance of private and shared spaces within the complex. The shared spaces allow for a variety of amenities, like a shared dining room and kitchen, guest suites, recreational facilities, sitting areas, exterior courtyard and a garden, which many members of this demographic group desire but may find difficult to afford or maintain. With the shared expense of such spaces in cohousing complexes, these facilities become manageable to offer, while still providing privacy of fully equipped separate units that allow for the senior residents to maintain a sense of independence in their individual home life. Also, by strategic placement of exterior and interior communal gathering spaces along transitional spaces and entrances within a compact, pedestrian-oriented housing complex, more social interaction and communication amongst the occupants is promoted, allowing each person to have social contact on a daily basis within or just outside of their home environments. The inclusive intergenerational focus also establishes a strong sense of

security and available help opportunities for the aging demographic. Through daily social interaction, a sense of comfort and development of relationships amongst neighbors is encouraged and all residents have the security of others directly available to them in case of need.

Single parents also benefit from the intergenerational cohousing focus on shared communal spaces that are integrated amongst the private dwelling units, which allows for the inclusion of facilities that some of these households would not be able to afford if living in a detached home setting. Such amenities include indoor and outdoor play areas designed to be within close proximity of the dwelling units. These areas allow for a direct access to public play facilities with added convenience for the parents or supervisors since the children are within direct view of one or more residents and close by the premises of the housing complex. Also, through a strong community focus, the intergenerational cohousing model provides single parents and their children with adamant social aid. With the incorporation of shared amenities and promotion of communal relationships amongst the residents through a densified plan, cohousing occupants share chores like the preparing of meals and supervising of other children within the complex. This divvying up of responsibilities diminishes the role overload of a single parent and allows for more spare time to spend with their children (Franck, 1989). The emphasis on community within these integrated environments thereby allows for a broad social advantage to single parents and their children who may feel a sense of isolation and loneliness.

As for the single young adult population, by occupying a tenancy where there is constant day-to-day social interaction opportunity, these individuals are given a greater possibility to meet and

integrate themselves into close-knit rural communities. With a more positive and communal housing typology, away from the isolation of single detached units, rural areas may become more appealing places for such individuals to move to and thereby support the economy and sustainability of these slowly declining rural societies.

All three of the user groups also benefit from the compact, efficient units within this intergenerational multi-resident cohousing model. The downsizing in space better suits the older adult and young adult population single or duo dwellers for their specific occupancy size. Also, since many seniors face mobility and health problems that make maintaining a larger home difficult (Jaffe, 1989), the condensed, smaller one or two-bedroom residences that are offered in the cohousing complex accommodate these issues in order to provide a comfortable and easily managed unit for their specified occupancy. The downsized units also provide an opportunity for single parents, especially those who may fall into the lower financial bracket due to reduced family income, and young adults to buy or rent a home that better suits their occupancy number and financial standing.

Cultural continuity is also established in this integrated living component of the project through incorporation of the variously programmed communal spaces. The cohousing project includes communal programs that integrate different aspects of culture, like food, clothing, literature, music and recreation. Promoting interaction amongst all ages with the inclusion of these programmed spaces supports cross-age learning and the passing down of cultural and historical knowledge from adults to youth while allowing youth to also educate on new innovations in technology and recreation to other age groups in the complex. The communal programs included in the rural cohousing project that support this cultural continuity through cross-age interaction

and learning consist of a music area, indoor recreation space, computer area, sewing and workshop space, reading room, kitchen, dining room, garden and multi-purpose seating areas.

Age segregation in the public and domestic social sectors and the social detachment that it fosters, along with such built environments as the single-family detached house, has insufficiently supported the changing needs of the diversified twenty-first century rural Canadian demographics. As professors and researchers, Karen A. Franck and Sherry Ahrentzen, state, "the diverse character and need of today's household population cannot be met by a single standard form that lacks flexibility and variety" (Franck & Ahrentzen, 1989, p. xiii). Turning towards alternative housing typologies that integrate rather than segregate would provide stronger social networks along with broadened knowledge and experience amongst all age groups. Scotthanson and Scotthanson support that "the movement back to community is the key to sustainability in Western culture" (Scotthanson & Scotthanson, 2005, p. 1). Hagestad and Uhlenberg (2006) also conclude that promotion of age integration throughout various societal sectors might be the key ingredient for reducing the increasing ageism in today's society along with nurturing societal generativity, which constitutes older adults' "ensuring continuity beyond one's own life span" (Hagestad & Uhlenberg, 2006, p. 647) through leadership, teaching, mentoring and parenting investments in younger generations.

4.3 ■ Methodology

With the intergenerational cohousing focus on turning back towards the small town culture of community living, how can this model for dwelling be encouraged among rural populations? Also, what

methods can be used to promote cultural and historical continuity and integrate the 'new' with the existing environment?

4.3.1 ■ Regionalism: Design of Resistance

As a response to encouraging age-integrated multi-resident housing models into rural Canada, the project follows strategies that help connect the design resolution directly to the specific locality of the chosen region through preservation and integration of the specific culture and site. Critical regionalist practice, which focuses on the development of culture, individualism, sense of place, atmosphere and identity in the built environment, is one of these strategies that the project follows. The incorporation of critical regionalist practice aids in informing material, formal and aesthetic design choices along with spatial configurations that establish a correlation between the 'new' development and the existing site.

As previously mentioned, out of a desire to follow the advancements of surrounding urban centers, rural regions throughout Canada now focus on constructing quick, cheap, replicated housing that has no connection or affiliation to their natural or contextual surroundings. With the shift towards mass production, a sense of uniformity began to take over the once individualistic nature of these rural regions and western Canadian life became "a product, not of the spirit, but of the technology" (Rees & Tracie, 1978, p. 5). In response to this encompassing uniformity throughout North America, architect and historian, Kenneth Frampton, aided in the founding and advocating of the use of critical regionalist design strategies. Frampton (1987) describes critical regionalist theory as a design application of resistance that veers away from standardization and mass production and the homogeneity it fosters. Instead, this theory has a locality-bound focus that

promotes connectedness between people of a specific culture, history, identity and ecology and their region through such design elements as color, material and form (Frampton, 1987). This local contextualism reinvents identity, sense of place and individualism and therefore becomes a vital ingredient for preserving the history and culture of the rural prairies within this specific cohousing design project.

4.3.2 ■ Traditional Use of the Locale

Sense of place is an experiential phenomenon that attaches meaning and a unique atmospheric character to a specific environment and is essential when establishing a connection between a physical setting and its inhabitants. Professor of Architecture and Planning, Steven A. Moore, describes the making of place as a "dynamic process that links humans and nonhumans in space at a variety of scales" (Moore, 2005, p. 433). Since the Modern Movement, with its concentration on an ideal universal expression and mainstream form, design has lost this sense of place and in turn developed a sense of 'placeless homogeneity' and lack of meaningful presence (Eggener, 2002). Through its various practice strategies, the first being traditional use of the locale, the critical regionalist process concentrates on reestablishing this lost sense of place and thereby positively enhances the built environment for the intended occupancy. Finnish architect, Juhani Pallasmaa (1988), speaks of this movement of developing meaning and feeling through application of tradition in his essay, "Tradition and Modernity: The Feasibility of Regional Architecture in Post-Modern Society." Pallasmaa (1988) identifies that the modern movement impaired a sense of locality and identity with its universal focus and that looking back at historical distinctiveness and individuality in design would be a step toward developing a reconnection between

people of a specific culture and their surrounding region. He advocates that design capable of supporting an identity has to be "situationally, culturally and symbolically articulated" (Pallasmaa, 1988, p. 130) through expressions and experience of a specific nature, geography, landscape, local materials, skills, and cultural patterns (Pallasmaa, 1988).

The first component to the traditional focus of reestablishing a connection and sense of place through historical use of the locale in this project is the incorporation of local materials. From the early settlements, people have been dependent on nature for their basic needs of survival, these being food, shelter and clothing. This essential reliance to the land formulated a strong connection between early settlers and their specific regional natural surroundings (Rees & Tracie, 1978). Through reintroducing this historical concentration of regional material use, and therefore local colors, textures and smells, a connection back to these once prominent ties to the land is reestablished and results in providing a sense of familiarity between the inhabitant and their built environment. Familiarity within an environment, according to environmental psychologist, Robert Gifford, promotes comfort and ease of mind (Gifford, 2002). So, with the focus on incorporation of local materials, colors and thereby socio-cultural familiarity, a healthy state of mind is nurtured through connecting people back to their roots and providing an evoking atmospheric quality to their built surroundings. With this design strategy in mind, the housing project uses such local material as naturally finished oak and birch wood, strawboard produced by wheat straw and local glass manufacturers as dominant material choices throughout many aspects of the design resolution. The cohousing development also works with a

color palette informed by imagery of Saskatchewan prairie along with the immediate surroundings of the chosen site (see figures 10-15).

The second component to critical regionalism's integration of tradition and the locale that the cohousing project incorporates is the use of specificity of form. Every region has a pronounced and unique character to their landscape and culture. The prairies have distinct, strong lines and characteristics of the land along with iconic imagery that are related to the landscape. The rural intergenerational cohousing project incorporates specific characteristics of the prairie landscape and the site itself through the drawing on one prominent conceptual word that was derived from this imagery and influences the design of this specific built environment. This concept, once again, is *continuity*. Continuity, for this design phase of the project, can be defined as the fact of being consistent throughout, of not stopping or being interrupted, and of evolving while revealing imprints of the past. Looking through selected imagery, continuity in the prairies is revealed through the unobstructed sight lines along with the unbroken horizon line with a land to sky ratio of 1:3 (see figure 16). The land, which is comprised of fairly flat fields and small

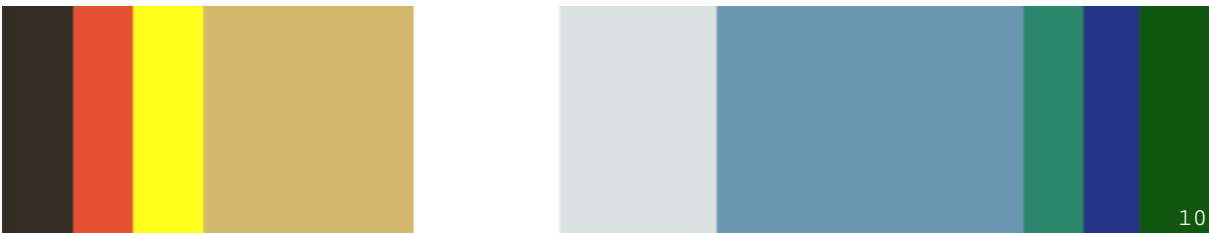

Figures 10-15 - A color palette taken from imagery of the Saskatchewan prairies and fields outside of Melville

Saskatchewan prairie

Infusing critical regionalist practice of using local materials and color in the design phase of the rural Canadian prairie intergenerational cohousing



Figure 16 - Continuity in the unobstructed sight and horizon lines in the Canadian prairie landscape

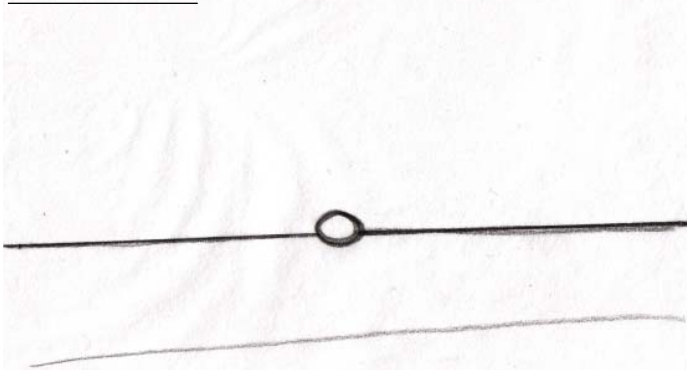

Figure 17 - Continuity in the uninterrupted connection of the railway across the Canadian prairies



hills and valleys, also creates a consistency throughout the Saskatchewan landscape with no major deviations. Also, the railway, which is a major industry in the selected site of Melville, forms an uninterrupted, fluid movement and connection across the Canadian Prairies (see figure 17).

An unobstructed and continual fluidity is portrayed through the selected images and is the specific characteristic that the Prairie cohousing project infuses into its design resolution through such elements as openness, expansion, puncture and pattern. A continuity through openness is established in the free planning, minimal use of solid, full height partitioning, and maximum use of built-in features within both the dwelling units and the communal spaces (see figure 18).

A continuity through expansion is brought forth primarily through the

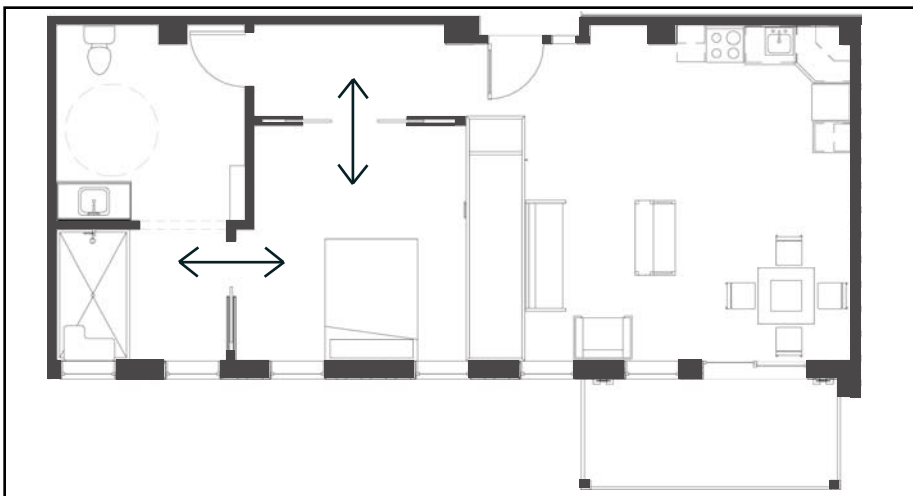
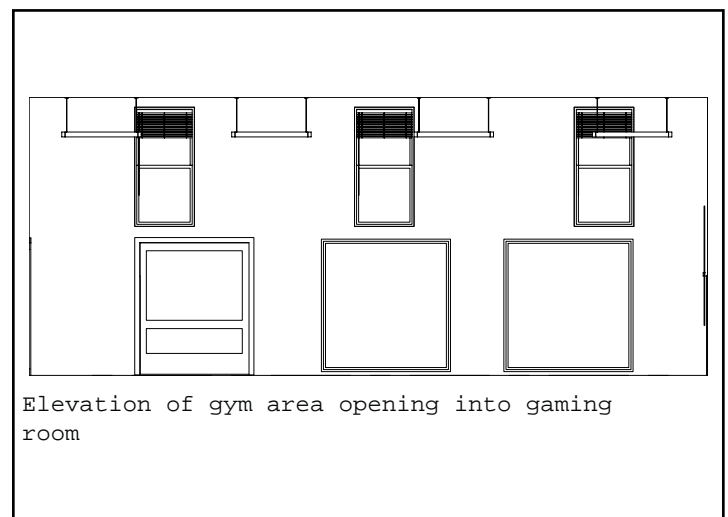
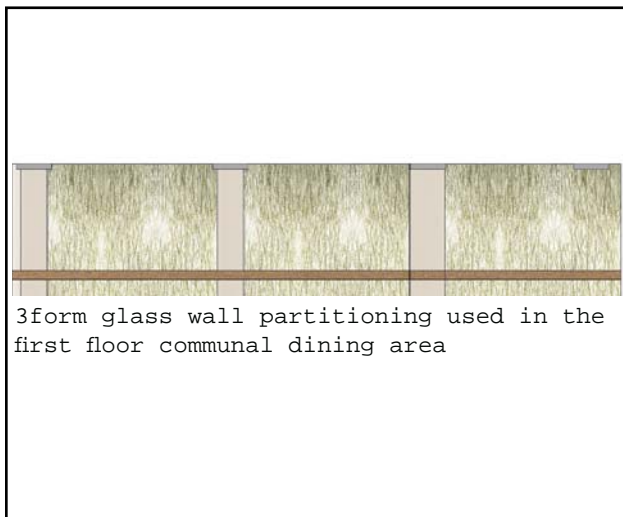

Figure 18 - Plan of a single bedroom suite in the rural Canadian prairie intergenerational cohousing model

Cohousing Complex
Melville, Saskatchewan
2009

Continuity through openness



Figures 19 and 20 - Doors and partitioning in the rural Canadian prairie intergenerational cohousing model

Cohousing Complex

Melville, Saskatchewan

2009

Continuity through expansion

use of sliding partitions that connect and open various spaces throughout the complex along with the introduction of glass partitioning within various elements of the design (see figures 19 and 20). Continuity through expansion is also established in the front and back developments that bridge inhabited space from the interior to the exterior. Continuity through puncture is created by constructing openings through the floor assemblies of various communal spaces throughout the complex that create a continuum through these communal spaces from



Figure 21 - Section through communal dining and kitchen areas in the rural Canadian prairie intergenerational cohousing model

Cohousing Complex

Melville, Saskatchewan

2009

Continuity through puncture

floor to floor (see figure 21). This continuum is also established through interior and exterior communal spaces by opening many of these public areas to the exterior courtyard with the use of balconies. Continuity through puncture is also revealed through the use of openings throughout solid partitioning to establish a continuum of light that passes between exterior to interior along with suite to hall to suite. Finally, continuity through pattern is promoted through the use of repetitive patterns like the grid, angular lines and horizontal emphasis of the selected prairie imagery, which also reflect structural components of the original hospital building (see figure 22), throughout different elements like finishes, lighting fixtures and partitioning in the design (see figure 23).

Alongside the use of local materials and specificity of form, the third component to exemplifying a high quality of life through the critical regionalist incorporation of the locale that the cohousing project focuses on is site inclusion. With a society that revolves around consumption, over abundant use of technological building systems has found favor over traditional natural systematic integration.

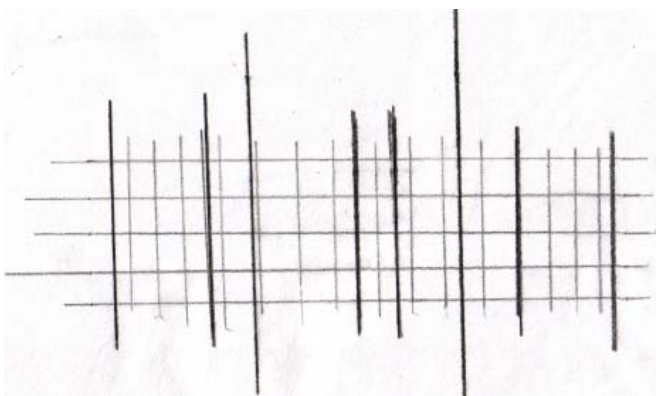

Figure 22 - Grid created by building elements in the former St. Peter's hospital
Cohousing Complex
Melville, Saskatchewan
2009
Continuity through pattern



Figure 23 - Emphasis of the grid used on the front addition and railing components of the rural Canadian prairie cohousing project
Cohousing Complex
Melville, Saskatchewan
2009
Continuity through pattern

According to Kenneth Frampton (1987), built forms are interactive with and responsive to nature, but the modern mechanical services that are so dominantly used have eliminated the relationship of the built form to its contexts. Making use of the potential opportunities that a specific site and climate offer, like natural sunlight and ventilation, not only contribute to fight against the energy crisis today, but also promotes a state of good health to the occupants of that built setting. Sunlight gives the human body a source of vitamin D and built environments that provide ample natural light can uplift its inhabitants' moods and increase work productivity (Gifford, 2002). The rural cohousing project begins to take advantage of some of these natural opportunities of its site through incorporating large operable windows throughout the complex to take advantage of the strong winds on site. The cohousing complex also takes advantage that Melville has one of the highest numbers of hours of bright sunshine in North America by bringing in as much natural sunlight as possible through large fenestration, glass balcony doors, glass construction on the front and back additions and skylights on the third floor. Although it has not been incorporated into this initial phase of the project proposal, there is also a prime opportunity do to these site conditions and the fact that the building has a flat roof of possibly incorporating a rooftop garden and communal space with further upgrades to the original structure.

Finally, the site is also incorporated into the spatial planning of the dominant path of exterior to interior movement through the complex. An east to west axis, which was derived from the movement of the sun on site, is established to create the horizontal movement of people from the back courtyard, into the interior communal space and out through the front yard development (see figure 24).



Figure 24 - Dominant path of horizontal movement through the building and site derived from the movement of the sun on site

Cohousing Complex
Melville, Saskatchewan
2009
Site inclusion

So whether through local material use, specificity of form or site incorporation, traditional inclusion of the locale aids in developing a historical and cultural continuity in the design phase of the project while also acting as an essential component to the development of place in the built environment and ensuring the occupancy's well-being. Wendell Barry, a Kentucky farmer and writer, sums this argument up best in his statement that people cannot comfortably inhabit a place if it lacks a connection (Barry, 1972), which critical regionalist practice works towards establishing between built environments and their inhabitants.

4.3.3 ■ Technological Innovation

The second component of the critical regionalist theory that corresponds with the development of continuity, the preservation of history while evolving through innovation, within the design project at hand is the infusion of contemporary strategy and technology. Vincent Canizaro (2007) addresses this duality focus for critical regionalist practice in the Introduction of his book *Architectural Regionalism: Collected Writings on Place, Identity, Modernity, and Tradition*. Canizaro (2007) addresses the fact that modernity is a driving force in today's society and that in attempting to keep up with the rapid

changes and evolutions, regionalist practice requires "the attenuation of tradition and continuity to attain the fruits of progress and innovation" (Canizaro, 2007, p. 23). By looking at tradition and contemporary ways to reinvent and apply it, critical regionalist theory works with this project to give direction to the reestablishment of the unique character and identity of the rural prairies through using up-dated and innovative solutions for rural intergenerational cohousing. The dominant application of the use of progressive technological techniques in the project is seen through the infusion of glass construction for the front and back additions with the original solid brick structure. This infusion is used as a facilitating component to establish the overall conceptuality of the design by creating the previously discussed focus on continuity between the exterior and interior and use of natural light.

4.3.4 ■ Adaptable Reuse: Intervention

The rural Canadian prairie intergenerational cohousing project has an established focus on preserving and expressing the local culture and nature of the chosen site. As a response to this focus, remodeling and adaptive reuse strategies of an existing culturally significant building within the town is another design strategy used in the development of this alternative housing project that helps to create a continuity and bridge the 'new' with the existing.

According to design professors, researchers and writers, Graeme Brooker and Sally Stone (2004), remodeling is a balance between the old and the new; the past and the future. Through analysis and incorporation of the original form and structure, history and function along with context and environment, the proposed function of the building can use strategies of intervention, insertion and installa-

tion to reinvent it and give the building new life (Brooker & Stone, 2004). The cohousing project focuses specifically on the adaptable reuse strategy of intervention. Intervention, according to Brooker and Stone (2004), is the transformation of a building where the existing of the old and the additions of the new become intertwined and dependent upon one another. The existing form and structure determines how the building is to be reused, form follows form, making any additions of new elements completely related to the original building (Brooker & Stone, 2004). Following these ideals, the use of the existing brick hospital with a load bearing structure and designated multi-private and communal spaces, fits with the proposed multi-unit housing program. Also, the incorporation of existing materials, structure, quality of space, history and context of the old hospital supports the projects focus on historical and cultural continuity by providing another layer of preserving the heritage and culture of the Canadian prairie town itself while evolving the building for a new use.

4.4 ■ Wrap Up

Continuity is incorporated on various levels in this project. Theoretically, continuity is focused on by looking at ways for historical and cultural preservation while progressing and evolving the old with new innovations through communal living, cross-age learning and critical regionalist design strategies. A resulting factor of the focus on preserving small town culture through a domestic setting, integrated living strategies, critical regionalist processes and adapting an existing building for a new use is a movement towards the promotion of rural, historical and cultural continuity which all support the conservation of socio-diversity within this Canadian setting.

Along with addressing the previously discussed questions and theories, there are various design issues brought forth in the cohousing project, specifically, how to design for the integration of various age groups in one housing complex while evoking a sense of community amongst the inhabitants, how to develop flexibility and universal accessibility in all of the public and private spaces required, and finally how to incorporate regional design identity in a built environment. In order to help inform a successful resolution for the rural intergenerational cohousing model, the project looks towards various precedents that have guided and directed some of the decisions made.

5.1 ■ Cohousing

Cohousing originated in the early 1970's in Denmark (Fromm, 1991) and, although spread worldwide, has only sparsely expanded into the Canadian borders. Most cohousing projects found in Canada were built almost twenty years ago and are concentrated in the provinces of British Columbia and Ontario. Due to its well-established roots in Denmark, one influential cohousing community that incorporates some of the same ideals as the rural intergenerational cohousing project is found in the original site of cohousing's beginnings, within the city of Roskilde, Denmark. The cohousing community of Jernstoberiet, "the foundry", was designed by architects Jan Gudmand-Hoyer, Jes Edvards and Helge Christiansen in 1981. This close-knit residential community is constructed within an old closed down iron foundry building and is made up of one common house measuring 3,230 square feet, an interior court measuring 6,500 square feet and twenty one dwelling units measuring from 410 to 1,370 square feet (see figures 25 and 26). The adaptable reuse strategies of reprogramming and enhancing the

Do to copyright issues please refer to McCamant, Kathryn, & Durrett, Charles. (1988). *Cohousing: A Contemporary Approach to Housing Ourselves*. California: Ten Speed Press. Page 90.

Do to copyright issues please refer to McCamant, Kathryn, & Durrett, Charles. (1988). *Cohousing: A Contemporary Approach to Housing Ourselves*. California: Ten Speed Press. Page 92.

Figure 25 - (Top) Jan Gudmand-Hoyer, Jes Edvards and Helge Christiansen Jernstoberiet, Roskilde 1981
Closed down foundry building repurposed into a cohousing complex

Figure 26 (Right)- Jan Gudmand-Hoyer, Jes Edvards and Helge Christiansen Jernstoberiet, Roskilde 1981
A - Common House
B - Interior Court
C - Storage and Workshop
D - Vegetable Garden
E - Play Ground
F - Terrace

original structure of the old iron foundry gives this cohousing project a unique character and brought the residents together through participation during the demolition and interior finish phases, promoting a strong sense of community amongst these individuals before they even inhabited Jernstoberiet (McCamant & Durrett, 1988). Working with an existing abandoned building and developing a solution that respects and correlates with its original structure are design strategies incorporated and used throughout the rural Canadian Prairie intergenerational cohousing model, and the Denmark example demonstrates an innovative solution for such renovation.

Also tying into the rural Canadian prairie cohousing project's focus on establishing a strong sense of community belonging, the common house and the interior courtyard, provided by the large central hall of the original foundry structure (see figure 27), presents the

Do to copyright issues please refer to McCamant, Kathryn, & Durrett, Charles. (1988). *Cohousing: A Contemporary Approach to Housing Ourselves*. California: Ten Speed Press. Page 97.

Figure 27 - Jan Gudmand-Hoyer, Jes Edwards and Helge Christiansen
Jernstoberiet, Roskilde
1981

The multi-purpose central hall provides gathering space for all members of the Jernstoberiet community to come together and participate in various activities together

residents of the Denmark cohousing project with multiple opportunities for play, festivals and informal gatherings. This bringing together of residents in a common area is another consideration that the rural Canadian cohousing project incorporates through the programming of various communal spaces throughout the entire complex that promote play, gatherings, conversation and impromptu encounters. Another influential component of the Denmark example that is considered in the Canadian cohousing project is the architects' strategic orientation of the individual dwellings. All units have a main entrance off the central hall on the inside, which promotes informal, everyday contact between the Denmark cohousing residents, once again building on the development of bonding between the inhabitants. This orientation of the units also allows each resident to have an uninterrupted view to the communal house and courtyard, strengthening the connection component to the community at large.

One aspect of Jernstoberiet and many other cohousing projects that the rural Canadian cohousing complex veers away from is their introverted emphasis. Most of these cohousing residences do not promote use by members outside of the community and seclude the use of communal spaces within the cohousing complex to the tenants. The rural

Canadian Prairie cohousing project looks towards ideals of including the entire town of Melville as a whole by incorporating public spaces that are intended to bring secondary and tertiary users outside of the complex residents into the vicinity, as demonstrated in the next precedent.

5.2 ■ Intergenerational Multi-Resident Living

The second precedent examined is the Multi-generational Housing Complex in Vienna by Franziska Ullmann and Peter Ebner (see figure 28). This 2,040 square meter, six-storey building was constructed between 1998 and 2001 in southern Vienna, Austria and demonstrates the possibility for the integration of multiple functions and various generational occupancy in a single, tightly woven complex (Schittich, 2007). The housing development includes shops, a café, office space, medical practices and apartments that vary in size and intended occupancy (see figures 29-31). The four types of residency units incorporated in the complex are: assisted living apartments, mini-lofts, family maisonettes and two to three bedroom apartments.



Figure 28 - Franziska Ullmann and Peter Ebner
Multi-generational Housing Complex in Vienna,
Austria
1998-2001

Integration of various public and private
functions with multi-generational occupancy

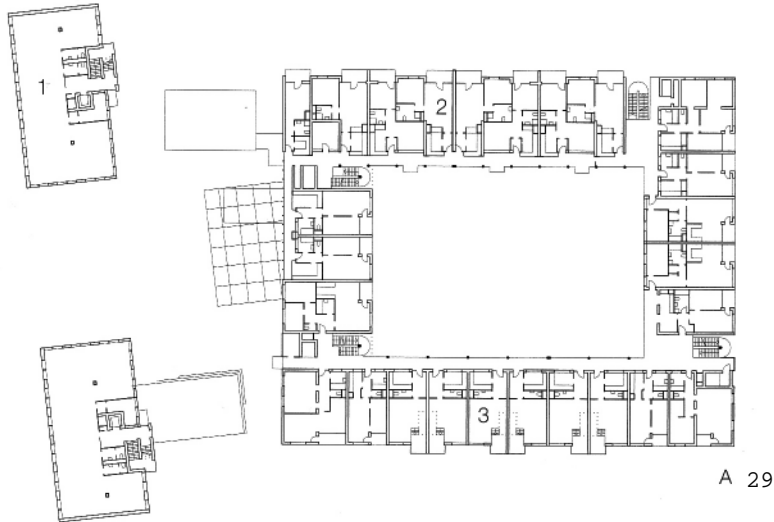

Figures 29 - 31 - Franziska Ullmann and Peter Ebner
Multi-generational Housing Complex
in Vienna, Austria
1998-2001

- A - Ground Floor Plan
- B - First Floor Plan
- C - Second Floor Plan

- 1 (office first floor/shop ground floor)
- 2 (assisted living apartment)
- 3 (family maisonette)
- 4 (temporary apartment)
- 5 (medical practice)
- 6 (Red Cross care station)
- 7 (cafe)

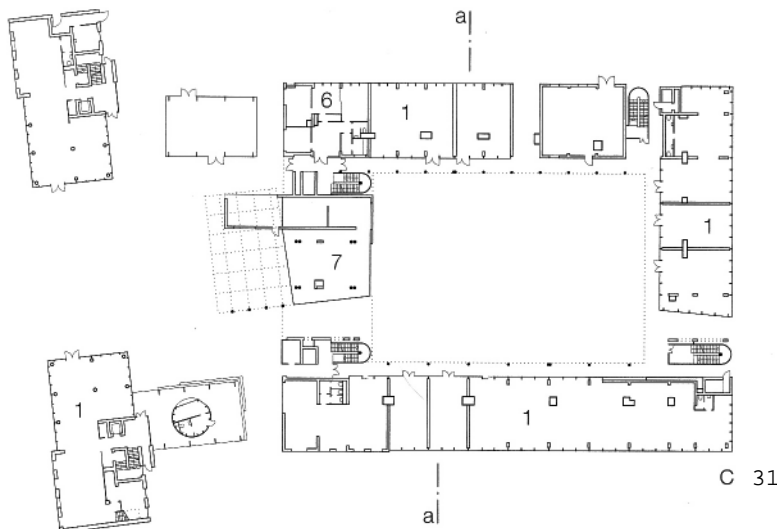
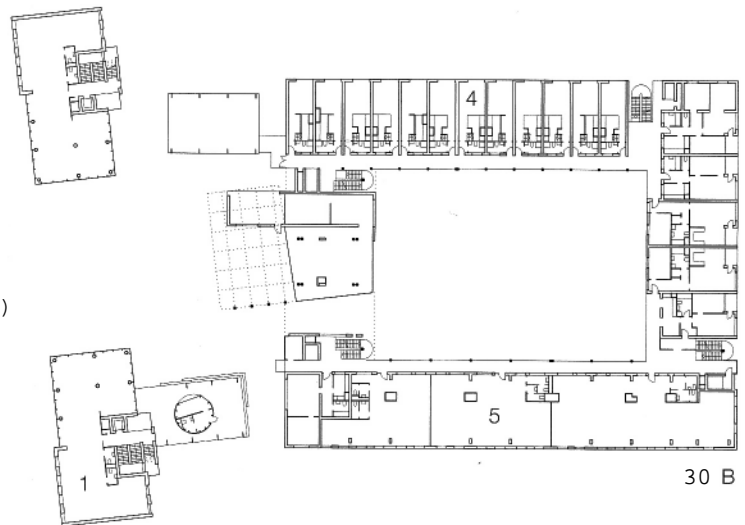

The inclusion of public programming on the bottom level of the complex, which includes a central courtyard, is a movement made by the architects towards integrating members of the surrounding community into the complex's resident community rather than segregating one from the other as seen in the previous cohousing example. This focus on promoting use by secondary and tertiary users is one influential component of the Multi-generational Housing in Vienna that is incorporated into the rural Canadian intergenerational cohousing model. Since the historical culture in many rural areas emphasizes strong ties to the community of the town as a whole, the incorporation of some public facility that could be used by all of the town's residents is a vital consideration to developing a contextual focus to the project. Through introducing public spaces that can be either rented out or frequently inhabited by other members of the community, like a communal kitchen, dining area and snack and coffee bar, not only promotes interaction and bonding amongst the residents, but it also strengthens the rural cohousing project's extraverted focus on integrating the larger community while forming a connection between the two.

The variation in scale along with the connection between each unit throughout the residential component of the Multi-generational Housing in Vienna are two other influential aspects that coincide with the rural Canadian Prairie cohousing project. The complex in Vienna designates different units according to size and accessibility to different users, from single students, to families, to residents in need of assisted living care. Although the rural cohousing project looks at designing for universal accessibility in most of its residential units rather than building specified spaces for particular users, the Vienna project's focus on bringing all ages together in one complex and some of the different techniques used in space planning, like the

use of space saving built-in features (see figure 32), are ideas that helped to guide some of the rural cohousing project's design strategies. Also, through connecting all units per floor with open walkways and facing each residential unit towards the central courtyard, reveals another emphasis that the Vienna housing complex has on promoting interaction and daily contact amongst the users of both the public and private sectors of the building. With a similar building form, the rural cohousing model takes advantage of the same extraverted focus on promoting communal integrated spaces and activities for all of its intended users.

Figure 32 - Franziska Ullmann and Peter Ebner

Multi-generational Housing Complex in Vienna, Austria
1998-2001

Kitchenette in mini-loft with built-in features like shelving and bed



5.3 ■ Critical Regionalism

The third and fourth precedents tie into the development of culture, identity and sense of place in the built environment through the use of critical regionalist ideals and practice. The first of these precedents is Alvar Aalto's Villa Mairea in Noormarkku, Finland (see figure 33). This approximately 4,500 square foot country house was built between 1937 and 1939 and was conceptualized around the idea of creating a "synthesis of modern technology, artisanship and nature" (Colquhoun, 2002, p. 202), while closely following ideals of critical



Figure 33 - Alvar Aalto
 Villa Mairea, Finland
 1937 - 1939
 Critical regionalist practice demonstrated
 through the use of local material and
 language



Figure 34 - Alvar Aalto
 Villa Mairea, Finland
 1937 - 1939
 Critical regionalist practice demonstrated
 through the use of local material and
 language

regionalist practice of integrating tradition and the locale. Connecting the house to its immediate surroundings of the clean, orderly, rugged, wooded landscape of Finland (Speck, 1987), cultural identity can be seen in this project through Aalto's emphasis on local material and crafty pillar partitioning within the orderly, relaxed interior of the Villa Mairea, which was derived from the surrounding forestry site (see figure 34). The residents of this country home relate on a personal level to these specific characteristic features of their local region and culture. And, since a sense of place involves the development of identity through an ambience that relates to the local culture and environment (Canizaro, 2007), the incorporation of such iconic characteristics through abstraction of built form and use of local material promotes a level of familiarity and comfort to the inhabitants.

Establishing a home environment that the inhabitants can relate to through this incorporation of local materiality and architectural language as in Aalto's project ties into the rural Canadian prairie intergenerational housing project's focus on the integration of regional design identity. Aalto's designs relate and connect to their inhabitants by developing a sense of belonging and expressive meaning through their specific locally inspired and influential forms and material use. The cohousing project looks to such examples as to how its own regional design identity could be studied and used to inform material, formal and aesthetic design choices and spatial configurations in its own design resolution.

While incorporation of tradition and the locale is one focus of critical regionalism's design process, there is no ignoring of a vastly increasing globalized society and its effects on the built environment. Instead of ignorance or envelopment, the critical regionalist embraces and infuses advancements of today's modern technological society with tradition in order to ensure the highest quality of living within their environments. As architectural writer and educator, Chris Abel, states, contemporary critical regionalist work reflects both the local space of nature and the global mind of the human culture in order to use and transform traditional practices (Abel, 2000). The fourth precedent regarding the rural prairie housing project, which provides insight into this contemporary component of critical regionalist practice in design, is the Jean-Marie Tjibaou Cultural Centre done by Renzo Piano in New Caledonia (see figure 35). With the concentration on critical regionalist practice of mixing traditional and contemporary construction systems, the design of these structures creates a unique, innovative specificity of form that coincides with the local culture. The traditional forms of the Centre that pay

homage to the local Kanak culture while drawing on surrounding natural elements like wind, light and vegetation (Lefaiivre & Tzonis, 2003) demonstrates the regionalist practice of infusing technological innovations in building structure, materiality and engineering with language of the local contextual site (see figure 36). With the focus on continuity of the history and culture of the rural prairies, the rural Canadian prairie housing project incorporates both the traditional use of the locale brought forth in Aalto's project and the use of contemporary construction strategies found in Piano's Centre that take advantage of the natural elements that the site offers, which are both driving forces behind critical regionalist practice.

Do to copyright issues please refer to Zabalbeascoa, Anatxu & Marcos, Javier Rodriguez (eds). (1998). *Sustainable Architectures: Renzo Piano*. California: Gingko Press Inc. Page 10.

Do to copyright issues please refer to Zabalbeascoa, Anatxu & Marcos, Javier Rodriguez (eds). (1998). *Sustainable Architectures: Renzo Piano*. California: Gingko Press Inc. Page 12.

Figure 35 - Renzo Piano
Jean-Marie Tjibaou Cultural Centre,
New Caledonia
1993-1998

Hybridized focus on infusing traditional form with advancements in structure, materiality and engineering

Figure 36 - Renzo Piano
Jean-Marie Tjibaou Cultural Centre,
New Caledonia
1993-1998
Traditional forms that draw on natural elements made possible through the use of innovative engineering

Program

The purpose of the project is to formulate a repurposed design program for the former St. Peter's hospital in Melville, Saskatchewan at 700 7th Avenue East. This program focuses on establishing a balanced complex of universal, integrated multi-resident living environments and public communal facilities that cater to the changing demographics within the rural Canadian prairies.

6.1 ■ Existing Site and Building Analysis

6.1.1 ■ Contextual Analysis

The intergenerational cohousing project has an underlying focus on rural continuity. The project looks at the ever declining rural Canadian regions, specifically located in the Prairie Provinces, and a possible housing proposal that may help to decrease these areas' loss of populace.

The dominant single-family detached house found throughout the rural areas have been found to be insufficiently suited to the needs of the increasingly diverse and changing demographics within these regions. As a response to the inadequate housing alternatives available throughout rural Canada, the housing project conceptualizes a movement away from single detached living and the possible isolation and segregation issues that these dominant twenty first century dwelling typologies can impose on their inhabitants. Through focusing on integrated living ideals, the project provides positive, healthy home environments for the targeted user groups and promotes such inhabitants to remain or move to these locations while advocating rural, cultural and historical continuity.

These regions hold a valid historical essence to the beginnings of Canadian culture and provide valuable resources to the whole of society. Through looking back at ideals in small town communal living and developing individual and regional identity through design and adaptive reuse strategies, the project advocates the sustaining of these rural regions in order to preserve their diminishing culture and promote the upholding of socio-diversity in the country's future.

6.1.2 ■ Site Analysis

The town of Melville, Saskatchewan is located in the southeast area of the province and is approximately 158 kilometers northeast of one of the provinces two major city centers, Regina, Saskatchewan (see figure 37). A major highway, Highway 10, runs along the perimeter of the town, from the northeast side to the southwest side. The town has

a population of about 4,500 residents and acts as a major stop in the Canadian National Railway along with recently accommodating the head office of the Saskatchewan Crop Insurance Corporation.



Figure 37 - Map of Saskatchewan, Canada



Figure 38 - Context and site map of former St. Peter's hospital in Melville, Saskatchewan

Melville experiences extreme temperatures ranging from +39 degrees Celsius during the summer months and -46 degrees Celsius in the winter. The chosen site receives ample natural light exposure. A soft, glowing morning light reaches the site from the northeast and a more direct, intense light reaches the site from the southwest during afternoon hours. Prevalent winds on the site also come from the west (see figure 38). This plentiful source of natural light provides

opportunity for a communal garden either along the west or east side of the site.

The selected building is located on a major street that dissects the town from east to west and acts as a school bus route and primary vein for movement of the town's population. The site has three prominent informal pedestrian paths along the east, north and south sides of the selected building that town members use as frequent jogging and walking trails (see figure 38). With a main location along such vehicular and pedestrian routes, the site is easily accessible and regularly inhabited by various town members, providing the opportunity for a broad range of users to the public programming brought forth with the repurposing of the former St. Peter's Hospital building.

The old hospital building is located on a seven-acre property with existing parking at the back east side and selective parking along the front west side (see figure 38). It is located about eight blocks from the downtown core and major amenities that the town has to offer like three banks, the post office, a pharmacy, doctor's office, one of the town's two major chain grocery stores, police station and several restaurants and shops. The building is surrounded by a residential neighborhood and has a park located two blocks west of the site and a school located three blocks southeast (see figure 39). Melville has a well-established wheelchair accessible taxi assistance that services all residents in need, specifically the town's nursing home and age segregated retirement complexes.

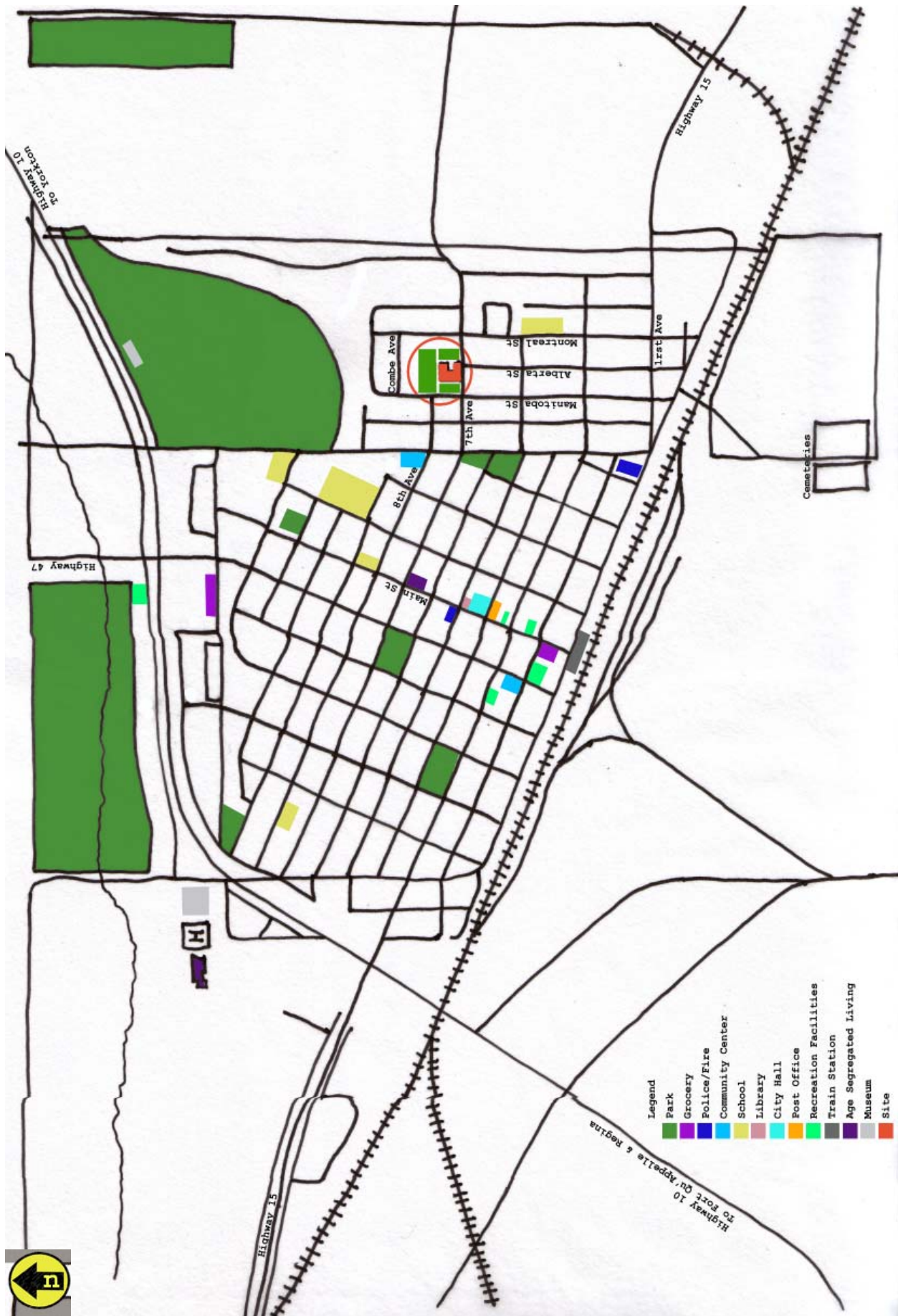

Figure 39 - Melville, Saskatchewan town map

6.1.3 ■ Building Analysis

The building being repurposed is a three-storey abandoned hospital with each floor measuring approximately 8,500 square feet (see figures 5-8). All three floors are being used in the renovation and the basement is being proposed for mass storage. The original central structure was built in 1941 and received north and south additions during the mid-to-late 1960's. The building is comprised of a solid concrete structure with two-toned brick facing on the exterior load-bearing walls. The u-shaped configuration of the building provides an opportunity to establish a semi-sheltered communal courtyard on the east side that could be potentially used by a variety of members from the community.

The former hospital has a very distinct symmetrical composition with placement of such elements as fenestration creating a continuous, even rhythm to its exterior. With a focus on the adaptive reuse strategy of intervention, where the existing structure completely informs the new programming and any possible additions so the old and the new are totally intertwined, these two prominent aspects of the original structure are considered and incorporated in the proposed design. Also, with such a solidified structure, the existing six exits and major circulation routes are relatively maintained within the new development (see figures 40-42) but the interior partitioning, lighting and heating, ventilating, and air conditioning systems are completely renovated and upgraded to suite the proposed domestic use.

The south side views out of the building face directly towards the main street of 7th Avenue East and is currently separated from the street by a row of trees (see figure 43). The north side faces a major pedestrian trail along with a large, open, undeveloped plot of land (see figure 44). The back east side faces towards the proposed

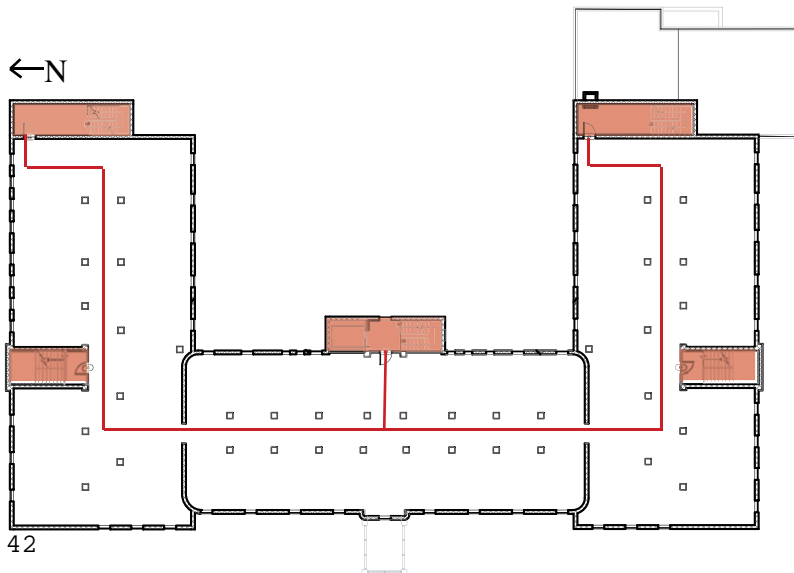
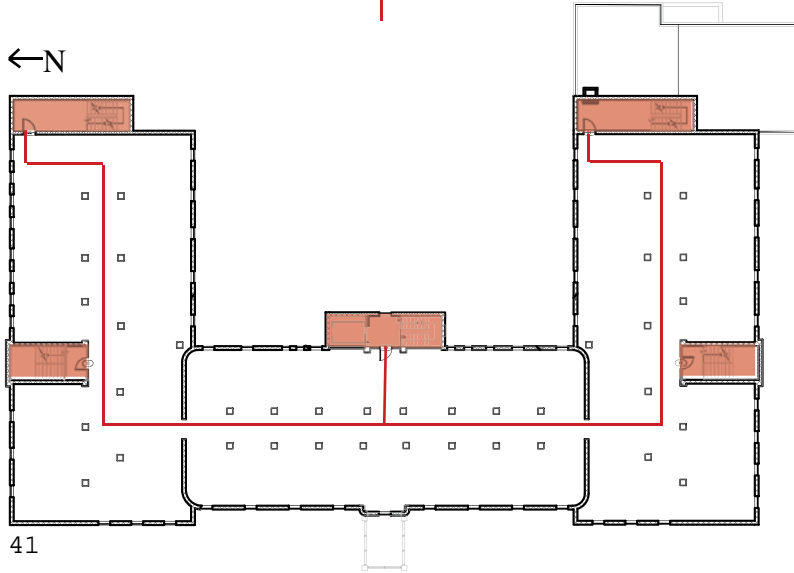
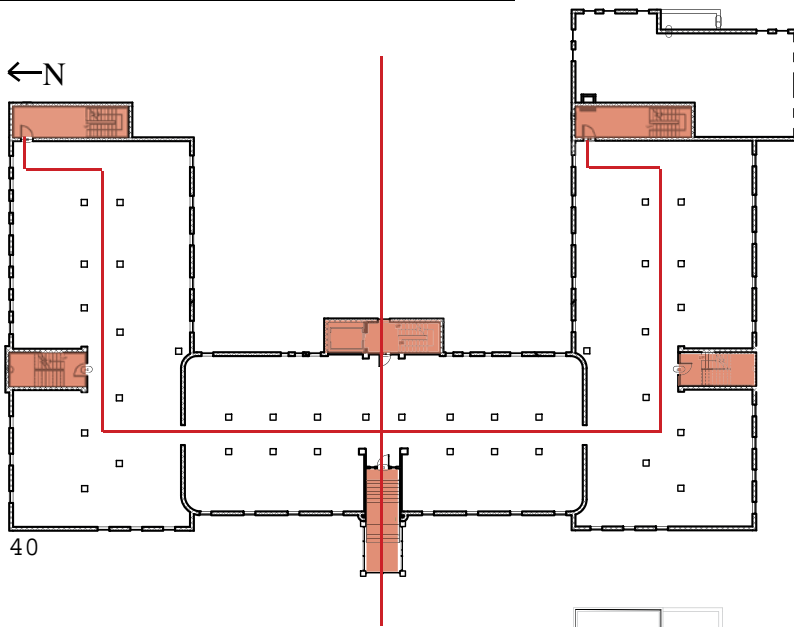

courtyard, another pedestrian path and the building's existing parking lot (see figure 45). Finally, the front west side views consist of a limited existing parking area along with an approximately 8,000 square foot grass yard area encompassed by trees around the perimeter (see figure 46).

Figures 40 - 42 - Former St. Peter's hospital original plan
 Former St. Peter's Hospital
 Melville, Saskatchewan
 2009
 40 - First Floor Plan
 41 - Second Floor Plan
 42 - Third Floor Plan
 Highlighted areas show existing vertical and horizontal circulation



Figure 43
Former St. Peter's Hospital
Melville, Saskatchewan
South View



Figure 44
Former St. Peter's Hospital
Melville, Saskatchewan
North View



Figure 45
Former St. Peter's Hospital
Melville, Saskatchewan
East View



Figure 46
Former St. Peter's Hospital
Melville, Saskatchewan
West View

6.2 ■ User Profiles

The targeted primary user groups for the rural Canadian inter-generational cohousing project that corresponds to the changing demographics in these regions are the older adult population, single parent households and single or duo young adults, which are all integral to the sustaining of these communities. All residents in the housing

complex must be self-efficient since assisted living services are not included in this facility. Since these primary user groups are comprised of smaller household member numbers and usually a single source of income, a compact multi-resident model for housing that incorporates shared communal facilities better suits these specific occupancies than detached housing. The focus on the integration and communal living of different age groups and individuals within one complex also supports such users by providing opportunity for the residents to form close personal cross-age relationships within their immediate home environments while promoting all inhabitants to be active members within the complex. This integrated living therefore aids in diminishing the progression of loneliness, depression, isolation and segregation that can develop with detached living amongst the targeted users.

The dwelling units cater to anywhere between thirty and forty residents and the public communal facilities throughout the complex cater to approximately the same capacity. The secondary and tertiary users of these public facilities are the entire township of Melville. By providing public arenas targeted at residents of Melville, both living within the complex and outside of it, on a major vehicular route that dissects the town, works towards the extroverted focus of the housing project to facilitate active interaction with all members of the community and preserving the small town culture of 'neighborly community-oriented living'.

6.3 ■ Programming

6.3.1 ■ Program

The new program for the former St. Peter's hospital building is an intergenerational multi-resident cohousing complex. The complex will include private, semi-private and public spaces (see figures 47-49). The private spaces include approximately twenty-two to twenty-six individual fully equipped dwelling units. These dwelling units are comprised of studio, one-bedroom, two-bedroom and three-bedroom configurations that promote a sense of independence and cater to the various user groups' household sizes and affordability. The minimal kitchen areas within the suites are about one quarter the size and capacity of the larger communal kitchen area. The dining space within each suite is also kept at a minimal size to promote frequent use of the communal dining spaces provided. Also, the basement is proposed for mass private storage use for all tenants of the complex and is fully accessible by stair or elevator.

The semi-private areas include communal seating areas and laundry facilities found throughout all three floors of the complex, along with reading room, sewing area, computer room, workshop, exercise space, guest suites, mass storage area, exterior garden and back parking lot and waste facilities. All of these semi-private communal areas are intended for sole use by the tenants of the housing complex itself or their visitors and are included with the intent to encourage everyday contact, cross-age learning and nourish a sense of belonging between the complex's residents.

The public spaces included in the housing complex are comprised of a communal kitchen, dining and snack and coffee bar areas, wash-room facilities, music area, gaming room and an open gym and indoor

play area that connects to the gaming room, which can all be rented out or frequented by the general public between the hours of 9:00 am and 10:00 pm. The back exterior courtyard spaces that are attached to the communal dining, snack and coffee bar areas, along with the exterior play area, are also open to the public when the adjacent interior spaces are being used. These particular communal areas are intended to bring other members of the Melville community to the cohousing complex and integrate the town as a whole rather than segregate the complex to a select few individuals, thereby taking a step to preserving the continuity of past small town culture through this community-oriented living. Except for the instance in two suites, all private, semi-private and public areas are designed to accommodate universal accessibility.

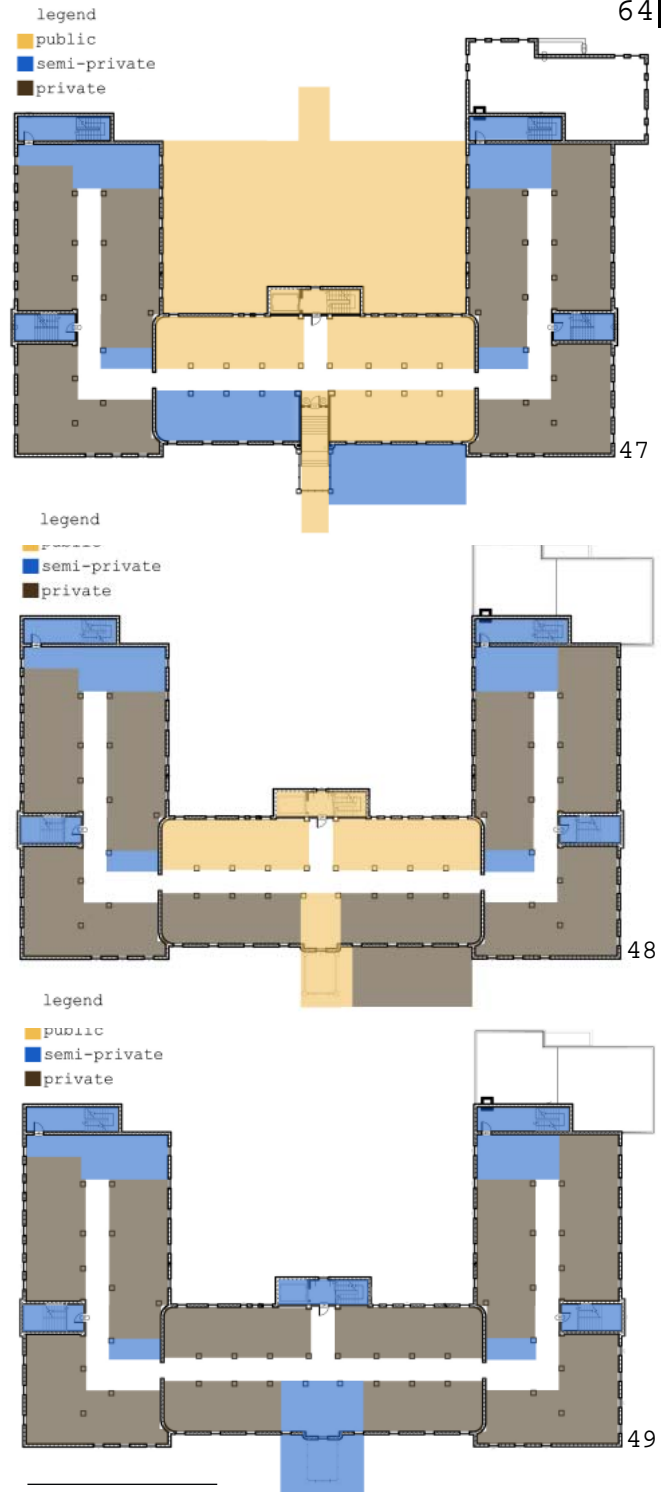

Figures 47 - 49 - Former St. Peter's hospital plan

Cohousing Complex
Melville, Saskatchewan
2009

47 - First Floor Plan

48 - Second Floor Plan

49 - Third Floor Plan

Study on public, semi-private and private space throughout the repurposed program of the old hospital building

6.3.2 ■ Spatial Adjacencies

Each space within the new cohousing program has been assigned adjacency preferences to one another from most desirable, to somewhat desirable, to not desirable (see figure 50).

	workshop	1 bed. suites	2 bed. suites	3 bed. suites	community dining	community kitchen	gardens	parking	outdoor play area	indoor play area	guest rooms	communal living spaces	mass storage	waste/recycling	gaming area	exercise room
workshop	3	3	3	3	3	3	2	3	3	3	3	3	2	3	3	
1 bed. suites		1	1	1	2	2	3	3	2	2	1	2	3	3	3	3
2 bed. suites			1	1	2	2	3	3	2	2	1	2	3	3	3	3
3 bed. suites				1	2	2	3	3	2	2	1	2	3	3	3	3
community dining					2	1	3	3	2	2	2	2	3	3	3	3
community kitchen						2	2	3	2	2	2	2	3	2	3	3
gardens							1	3	2	3	3	3	3	3	3	3
parking								1	3	3	3	3	3	2	3	3
outdoor play area									1	3	3	2	3	3	2	2
indoor play area										1	3	2	3	3	2	2
guest rooms											3	2	3	3	3	3
communal living spaces													2	3	3	2
mass storage														1	3	3
waste/recycling															1	3
gaming area																1
exercise room																

Legend
 1 - Most desirable
 2 - Somewhat desirable
 3 - Not desirable

Figure 50 - Adjacency study for the different programs in the new cohousing complex

6.3.3 ■ Functional, Technological and Spatial Requirements

(see appendix A).

6.3.4 ■ Aesthetic Concept

With a focus on establishing regional identity in design through critical regionalist practice, the aesthetic concept for the cohousing project is derived from prominent imagery, color, shape, texture, pattern and materiality found throughout the Saskatchewan prairies. Since the project looks at rural continuity and the prairie landscape itself upholds a strong sense and imagery of continuity, this word becomes the basis of bringing that local foundation into the regional identity component of the design resolution.

Continuity, in regards to the design phase, is the fact of staying the same, of being consistent throughout, or of not stopping or being interrupted. Continuity is pronounced in the prairie landscape through such elements as unobstructed sight lines along with an unbroken horizon line with a land to sky ratio of 1:3 (see figure 16). Continuity is also seen through the makeup of the land, which is comprised of fairly flat fields and small hills and valleys and is fairly consistent throughout the province of Saskatchewan with no major deviations. The railway, which also speaks of continuity, forms an uninterrupted, fluid movement and connection across the Canadian Prairies (see figure 17). Continuity is also demonstrated in the prairies through repetitive patterns like the grid, angular lines and horizontal emphasis, which are extracted from the selected prairie imagery and also reflect structural components of the original hospital building (see figures 22 and 23). This local sense of continuity is brought into the project's design through spatial configurations and formal design decisions.

Another component to establishing a regional identity through the aesthetic concept in the rural housing project is through use of local materiality that has some affiliation to the Canadian prairies. This

use of local materiality brings familiar elements of the natural landscape, like texture, color or pattern, into the physical composition of the design resolution and supports the continuity and preservation of the regional character in this project. Local imagery of the Saskatchewan prairies also influences other materiality and finish choices in color, texture and pattern.

6.4 ■ Building Code Review

700 7th Avenue East

This project involves interior and exterior alterations and additions to the existing former St. Peter's hospital building at 700 7th Avenue East in the town of Melville, Saskatchewan. The net floor area per storey for this project is 8,500 sq. ft. (770 sq. m.). The existing three-storey building originally consisted of the central space and had the north and south additions constructed at later dates. The project proposes to use all three storeys with storage located in the basement. The original structure is built with noncombustible construction. It has a solid concrete structure with all exterior walls acting as load bearing walls. These exterior walls are comprised of concrete and brick facing. There are interior concrete block walls that create firewalls along the stairwells. Interior partition walls are wood-frame with drywall. The building is sprinklered. All work done on this project shall meet or exceed the most recent National Building Code requirements.

3.1.2.1. Major Occupancy Classification

The existing hospital building is being renovated into a multi-resident cohousing complex. This residential occupancy is classified as a Group C Occupancy.

3.1.17. Occupant Load

The net area per floor is 8,500 sq. ft. (770 sq. m.). For each dwelling unit the occupant load shall be based on allotting two persons per sleeping room.

The project incorporates a communal dining and kitchen area. Allotting 1.2 sq. m. per person for the public dining area will allow a maximum of 57 persons in the space.

3.2.2.10. Streets

The building is located on the intersection of two streets, 7th Avenue East to the south and Manitoba Street to the west. There are also two public, frequently used alleys that run along the north and east sides of the building.

3.2.2.48. Group C, up to 3 Storeys, Sprinklered

The building can be combustible or noncombustible construction. The existing roof and building structure are noncombustible construction. Mezzanines will be made on the second and third floors and these mezzanines will have a fire-resistance rating not less than 45 min. The front and back additions will also have columns that have a fire-resistance rating not less than that required for the supported assembly.

3.2.4.11. Smoke Detectors

Alongside the existing fire alarm system, each public corridor will have smoke detectors installed.

3.2.8. Mezzanines and Openings through Floor Assemblies

All mezzanines will terminate at an exterior wall, a firewall or a vertical shaft.

The penetration of a floor assembly by an exit or a vertical space shall conform to the requirements of Sections 3.4, 3.5 and 3.6.

3.3.1.17. Guards

Guards not less than 1,070 mm high shall be provided at each raised floor, mezzanine, balcony, gallery, interior or exterior vehicular ramp, and at other locations where the difference in level is more than 600mm.

Unless it can be shown that the location and size of openings do not present a hazard, a guard shall be designed so that no member, attachment or opening located between 140mm and 900mm above the level protected by the guard will facilitate climbing.

3.3.1.9. Corridors

The minimum width of a public corridor shall be 1,100 mm.

The public seating areas within the corridors will not reduce the unobstructed width of the corridor to less than its required width.

3.4.2. Number and Location of Exits

There are five existing exits that will be maintained. Maximum travel distances will not exceed 82 ft. (25 m.).

3.4.3.6. Headroom Clearance

The headroom clearance for stairways measured vertically above any landing or the nosing of any stair tread shall be not less than 2050mm.

9.5.3.2. Mezzanines

The clear height above and below a mezzanine floor assembly in all occupancies shall be not less than 2.1m (6' 10.7").

3.4.5. Exit Signs

Exit signs will be provided at all exits.

3.7.2. Plumbing Facilities

Two universal public washrooms will be provided in accordance to the occupancy of the public dining and kitchen facilities and be located on the mezzanine levels over looking these areas.

The number of water closets for the residential occupancy will be at least one for each ten persons of each sex.

3.8.3.12. Universal Toilet Rooms

All standards for size, grab bars, etc. will be met.

3.8.3.4. Ramps

The exterior ramp will have a width greater than 870 mm between handrails. It will also have a slope of 1 in 12 and areas not less than 1,500 by 1,500 at the top, bottom and intermediate levels of the ramp.

3.8.3.5. Passenger-elevating Devices

The passenger-elevating device installed at the front entrance shall conform to CAN/CSA-B355 "Lifts for Persons with Physical Disabilities."

Zoning Review

The building fronts onto one street - Manitoba Street to the west. All yard setbacks and building heights are currently met and will be maintained.

The occupancy will be a multi-resident cohousing complex.

There is ample existing on-site parking on the east and west sides of the building.

6.5 ■ Design Guidelines

With the wide mix of public, semi-private and private areas included in the rural Canadian intergenerational cohousing model, several design guidelines must be considered. The issues identify objectives and aid in developing concepts that inform different design decisions made throughout the project. Four main areas where these issues are found that the design resolution much attend to are cross-age design, cross-age networking, individual and regional identity in design and intervention through adaptive reuse.

6.5.1 ■ A Home for all Ages and Abilities

Issue: Universal Access

Objective: To create all spaces throughout the complex to be universally accessible

Concept: Consider bringing the front or back entrance to ground level and including a stairwell and lift to access the main floor

Concept: Consider introducing a ramp on the front or back for access into the building

Concept: Consider open roll-in showers within each suite

Concept: Consider five foot turning radii throughout each private, semi-private and public area

Concept: Consider sliding partitions or folding doors throughout the dwelling units to allow for spaces to be opened up in case of need for more movement room

Concept: Consider multiple height counter tops

Concept: Consider the use of lever door handles and single levers with pull out nose on sinks

Concept: Consider electrical outlets placement at eighteen inches above the floor

Concept: Consider flush transitions between flooring

Concept: Consider use of built-in features to allow for maximum open floor space

Concept: Consider a projecting element from wall along all pathways that can be used for support

Issue: Noise Transference

Objective: To provide individual dwelling units with some privacy and noise reduction from public and semi-private areas

Concept: Consider placing dwelling units away from major public areas

6.5.2 ■ Networking

Issue: Internal Communal Development

Objective: To provide opportunities for the residents of the housing complex to engage in face-to-face interaction and establish a strong sense of community amongst these individuals

Concept: Consider multiple gathering spaces throughout all areas of the housing project

Concept: Consider communal programs that bring all ages together and promote cross-age learning like gardening, cooking, reading, computer usage, workshop and gaming

Concept: Consider use of main entrances to promote daily contact between inhabitants

Issue: External Communal Development

Objective: To provide opportunity for town members to be integrated into the complexes activities

Concept: Consider programs that can be used by other members of the community like communal dining and kitchen and recreation areas

Concept: Consider placement of public areas along major entrances and pathways that are used by both the tenants and town members

Concept: Consider exterior additions that bridge the external community with the internal community like balconies, decks and translucent glazing

6.5.3 ■ Identity

Issue: Individual Identity

Objective: To allow the tenants of the complex to establish personalized space within their own individual dwelling units

Concept: Consider the use of neutral colored finishes as the backdrop for the dwelling units

Concept: Consider open planning for different furnishing arrangements within the dwelling units

Issue: Regional Identity

Objective: To develop, represent and integrate regional characteristics of the surrounding site and context

Concept: Consider the use of locally made and found material in the design

Concept: Consider infusing prominent characteristics of the prairie landscape like color, shape, pattern and texture into the design

Concept: Consider the use of traditional building elements of historical housing in the rural Canadian prairies

Concept: Consider maximal use of the natural light and ventilation that the site offers

Objective: To develop a sense of continuity taken from the aesthetic concept in the design resolution

Concept: Consider connecting communal spaces vertically by creating overhangs on the interior and exterior

Concept: Consider the use of translucent and transparent partitioning to visually connect the public and semi-private spaces

Concept: Consider the repetitive use of dominant characteristics of the Canadian prairie landscape like material, color, shape, pattern and texture

Concept: Consider punctures in partitioning that connect light from exterior to interior, suite to hall, and room to room within the suites

6.5.4 ■ Intervention

Issue: Building Integrity

Objective: To use the original building language and layout to inform new design decisions

Concept: Consider maintaining original exits and paths of travel

Concept: Consider the dominant characteristics of the original building like linearity, symmetry and solidarity in any external or internal alterations

Concept: Consider the integration of the strong geometrical qualities and elements within the original structure like columns, fenestration, floor spacing, and ceiling heights in any the interior and exterior alterations

Concept: Consider any new additions to complement and enhance the above qualities of the original building

7.1 ■ Melville Cohousing

7.1.1 ■ Site and Exterior



West View



East View

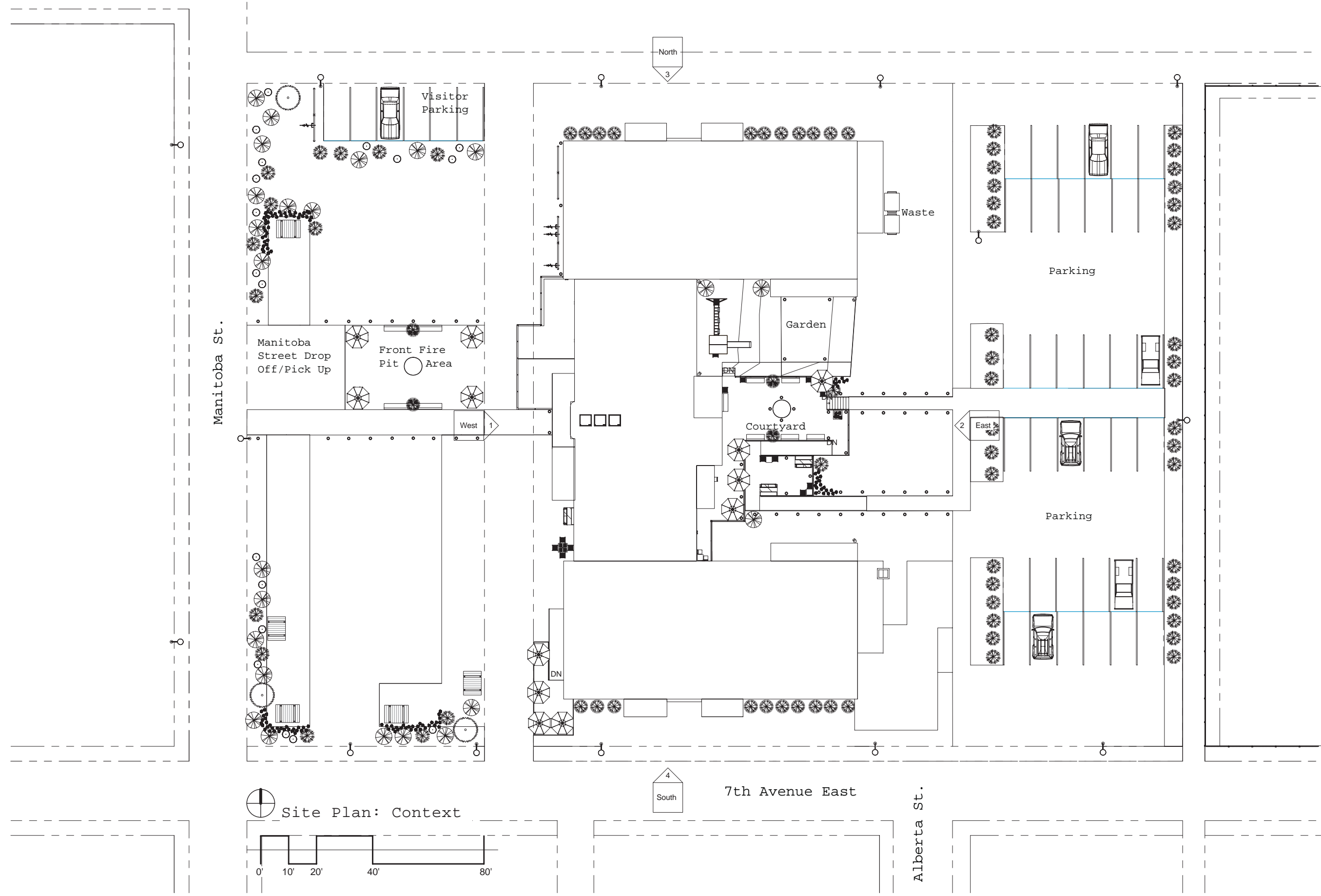



 Site Plan: Material



Original



West Elevation



West Elevation



East Elevation



East Elevation



Original



North Elevation

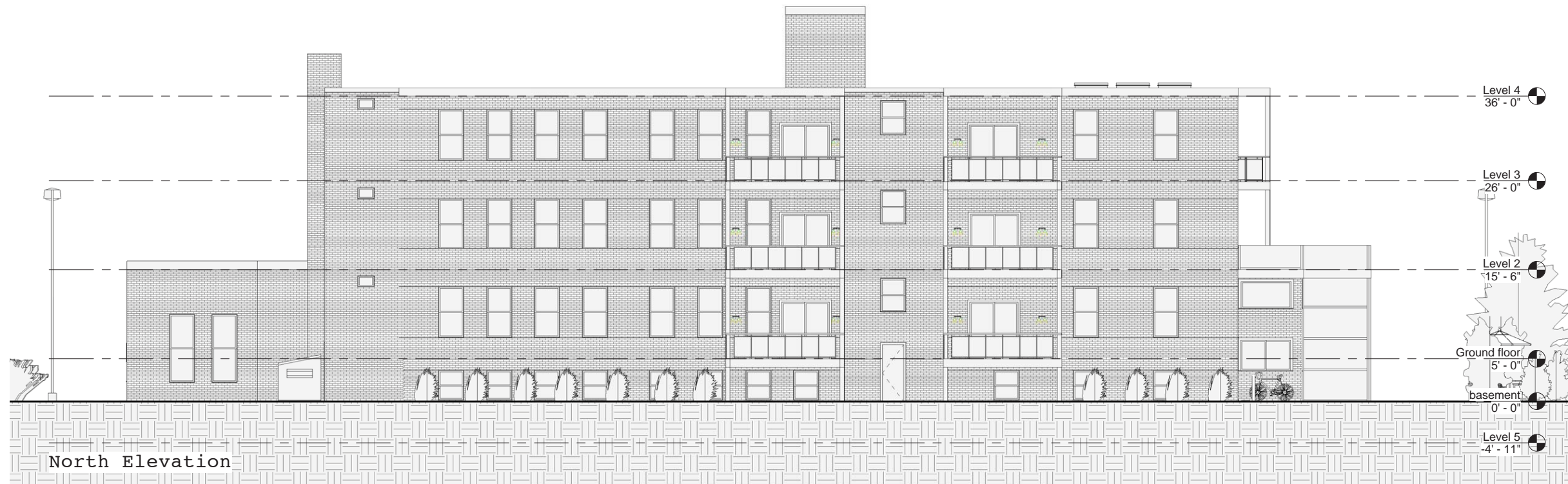

North Elevation



South Elevation





Front Perspective

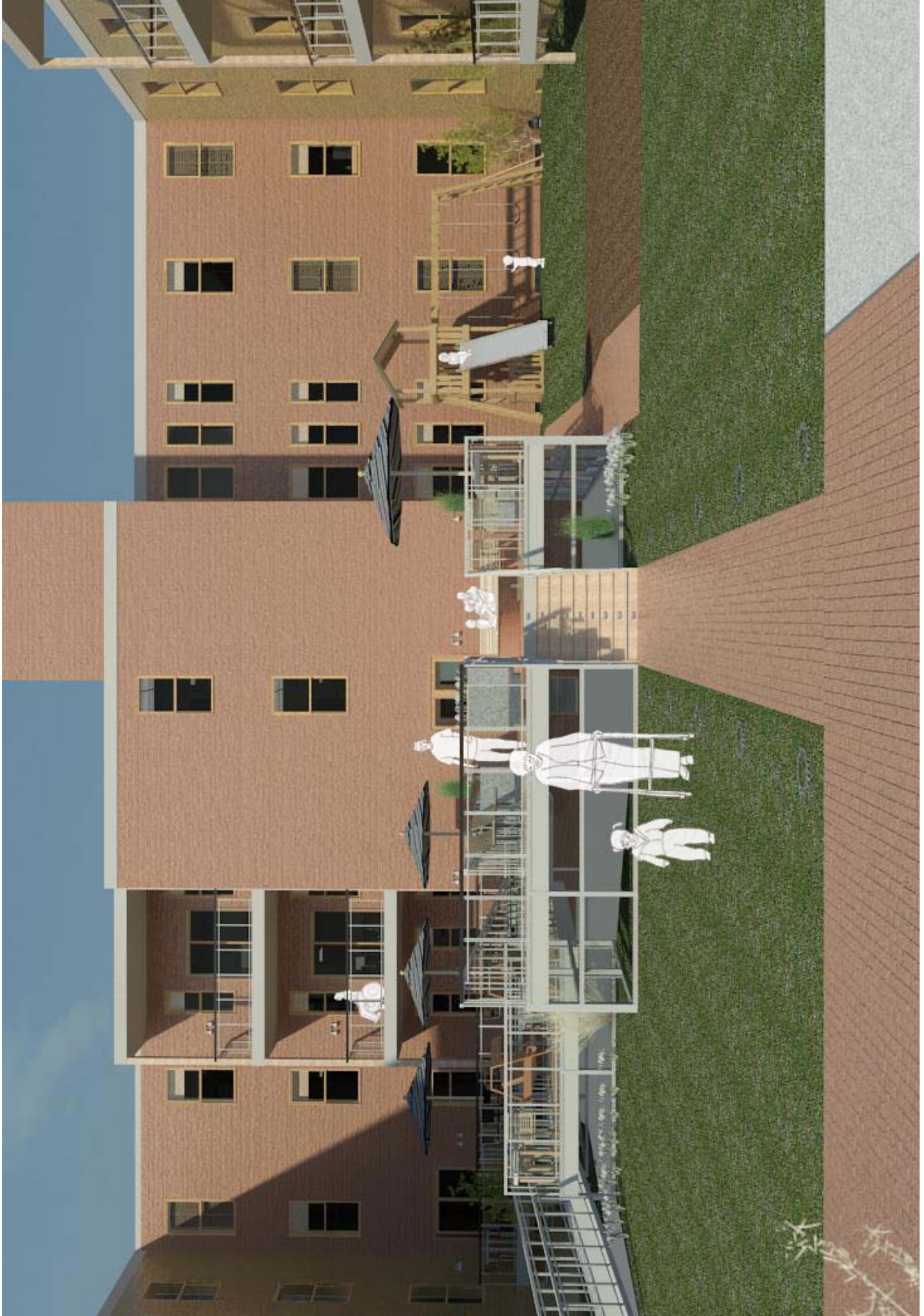

Back Perspective

7.1.2 ■ Interior Planning

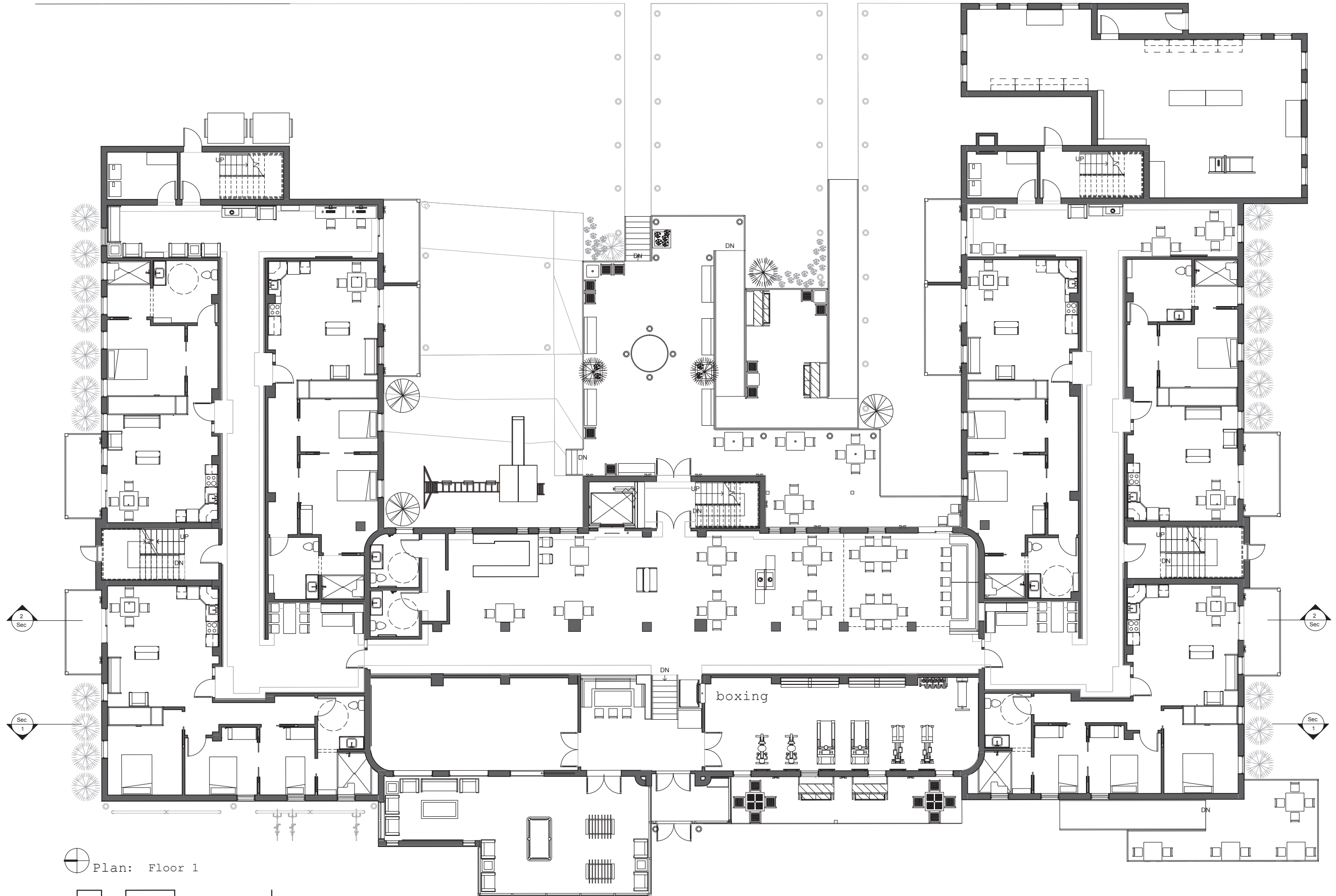

Plan: Floor 1

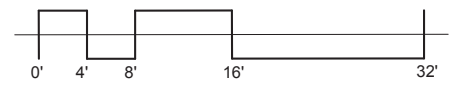

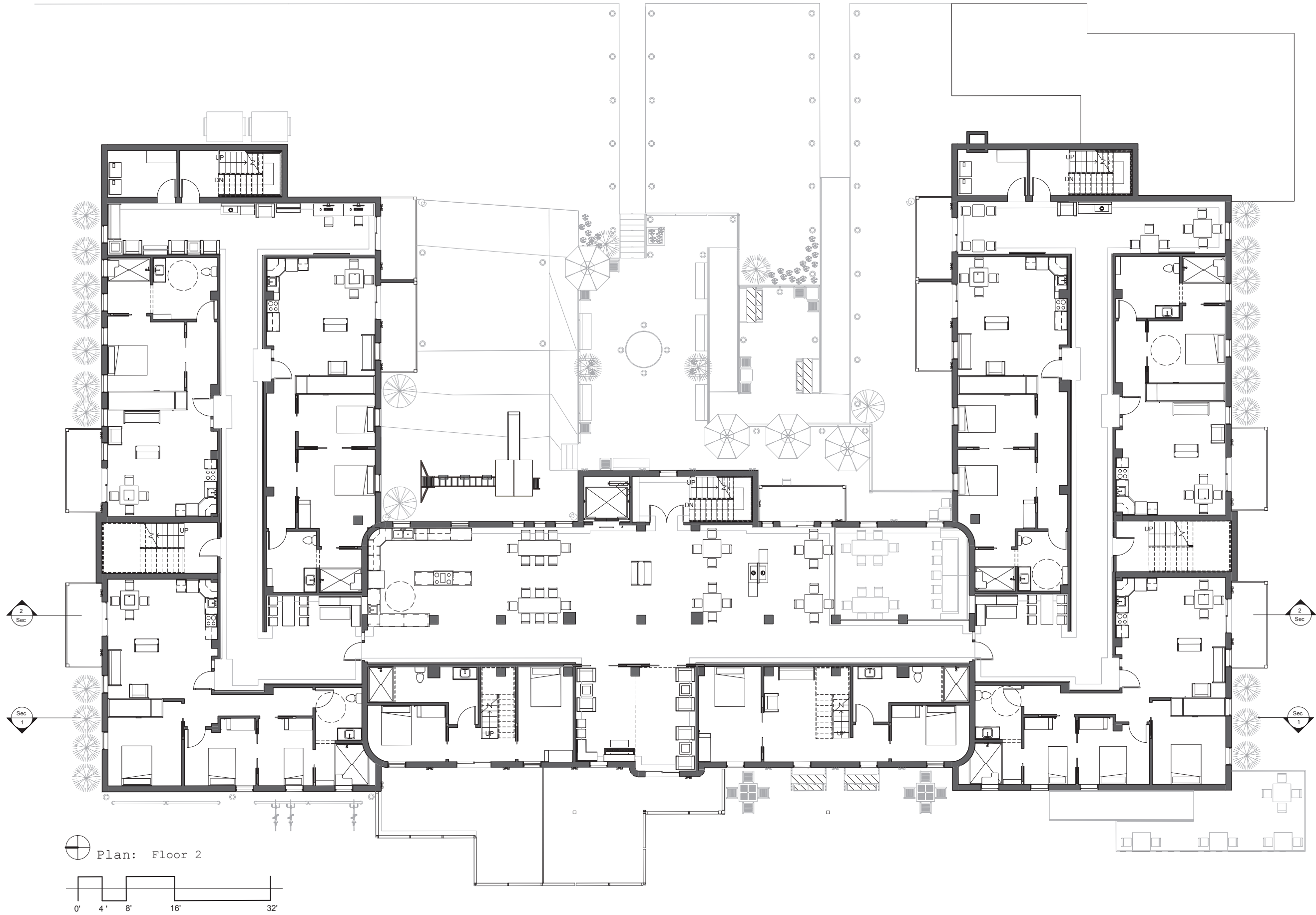

Plan: Floor 2

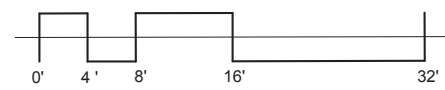

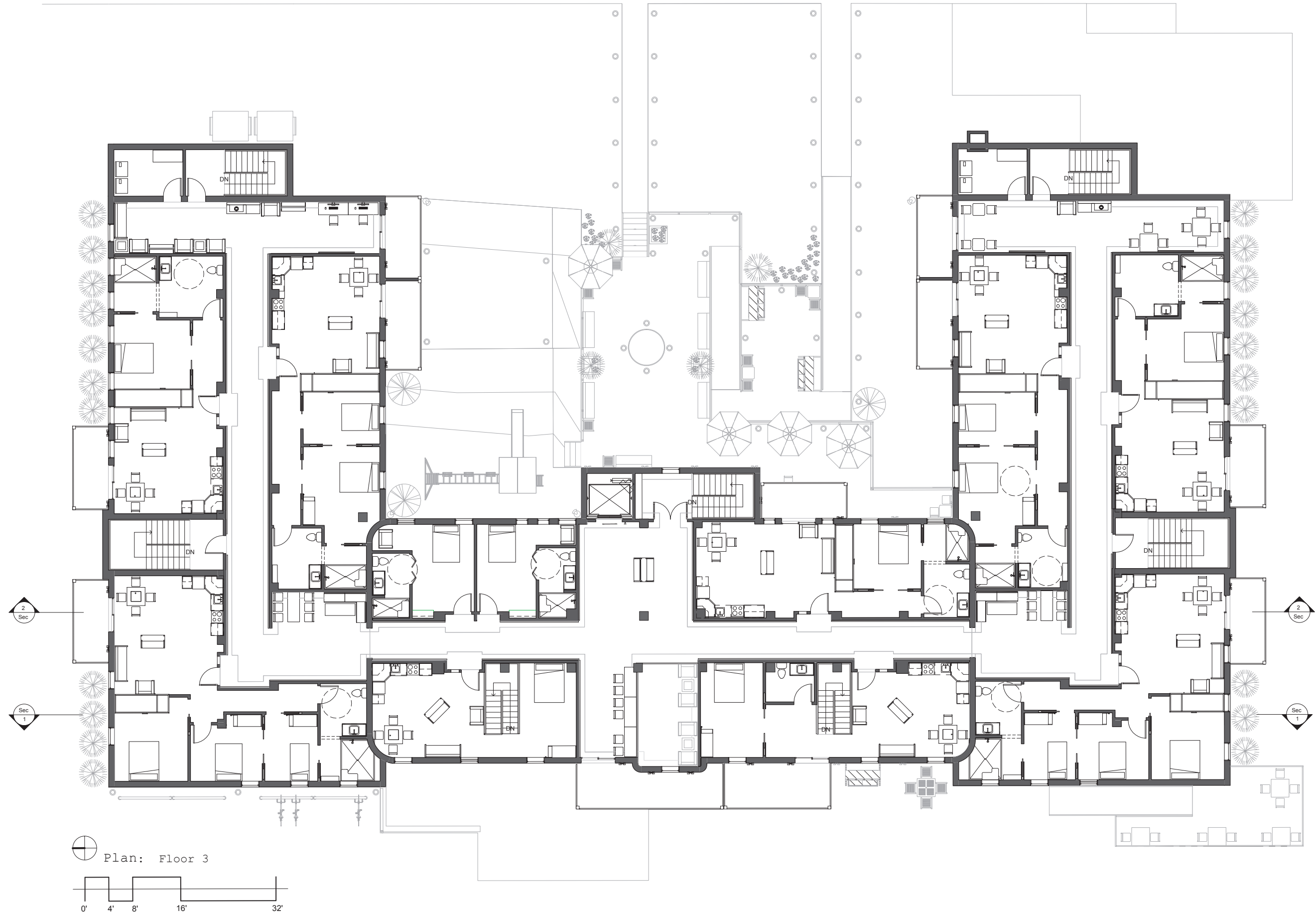

Legend:

- 6" Recessed Downlight
- ⊗ Exit Sign
- Ceiling Light: 2' x 2' Linear Box
- 8" Recessed Downlight
- ▬ Surface Mounted Fluorescent Tube Strip
- Ceiling Light: 4' x 2' Linear Box
- ⊙ Cube Pendant Light
- └ Wall Mounted Square Sconce
- ▬ Hanging Fluorescent Tube Strip

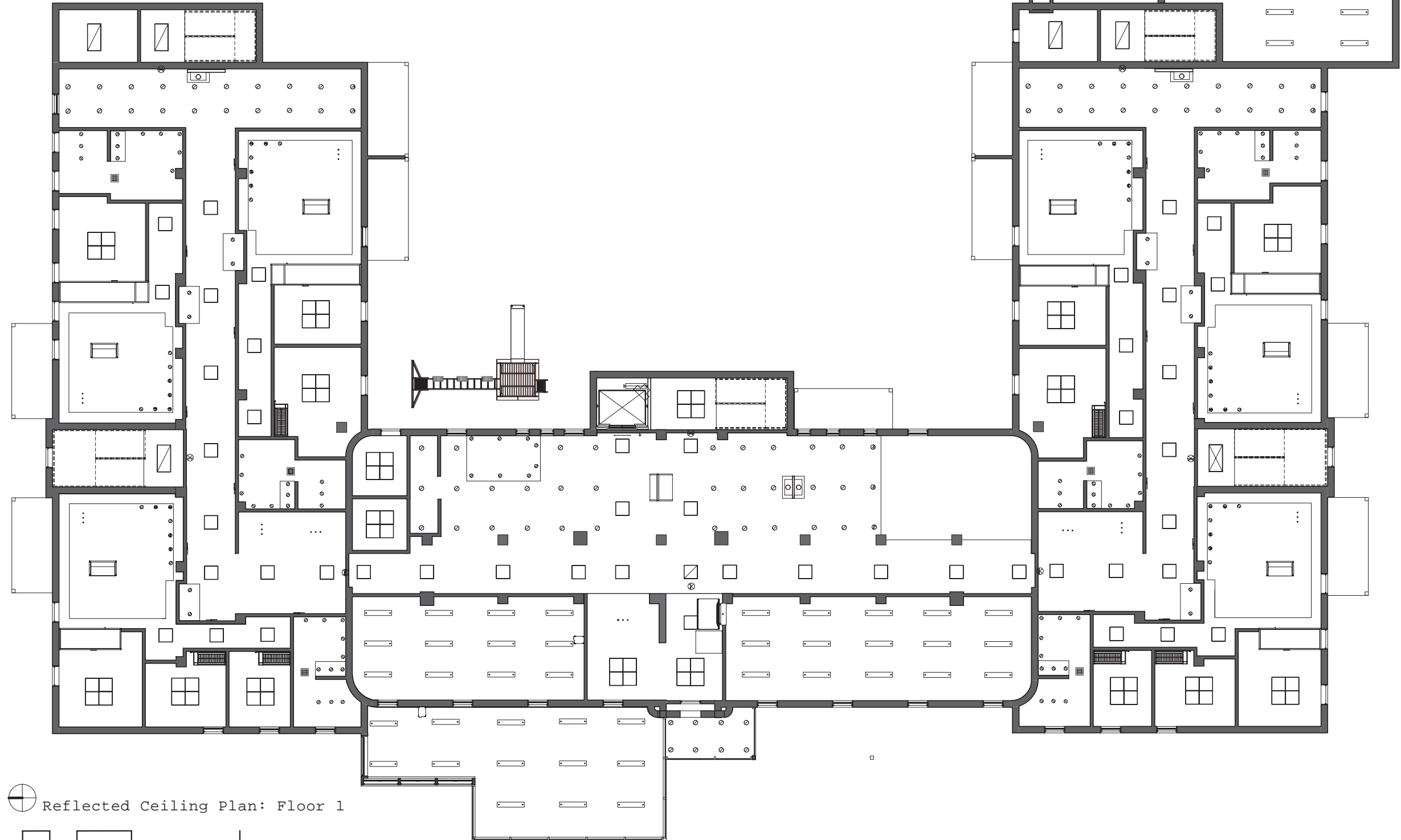

Reflected Ceiling Plan: Floor 1

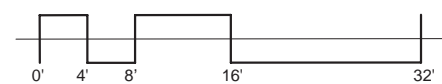

Legend:

- 6" Recessed Downlight
- ⊗ Exit Sign
- Ceiling Light: 2' x 2' Linear Box
- 8" Recessed Downlight
- ▬ Surface Mounted Fluorescent Tube Strip
- Ceiling Light: 4' x 2' Linear Box
- ⊙ Cube Pendant Light
- └ Wall Mounted Squares Sconce
- ▬ Hanging Fluorescent Tube Strip

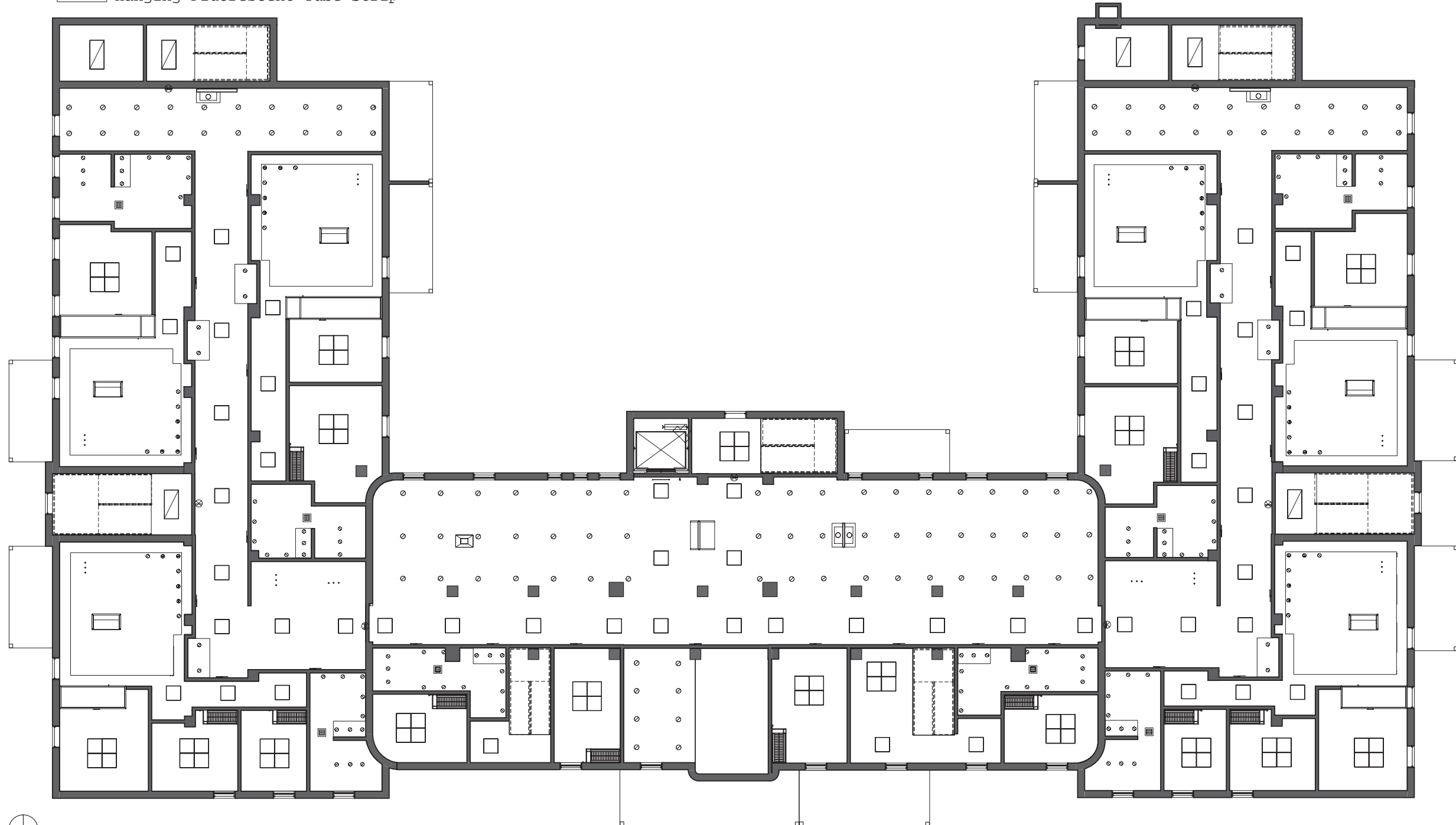

⊕ Reflected Ceiling Plan: Floor 2

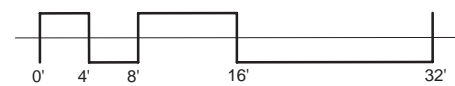

Legend:

- 6" Recessed Downlight
- ⊗ Exit Sign
- Ceiling Light: 2' x 2' Linear Box
- ⊙ 8" Recessed Downlight
- ▬ Surface Mounted Fluorescent Tube Strip
- Ceiling Light: 4' x 2' Linear Box
- ⊙ Cube Pendant Light
- └ Wall Mounted Squares Sconce
- ▬ Hanging Fluorescent Tube Strip
- Skylight

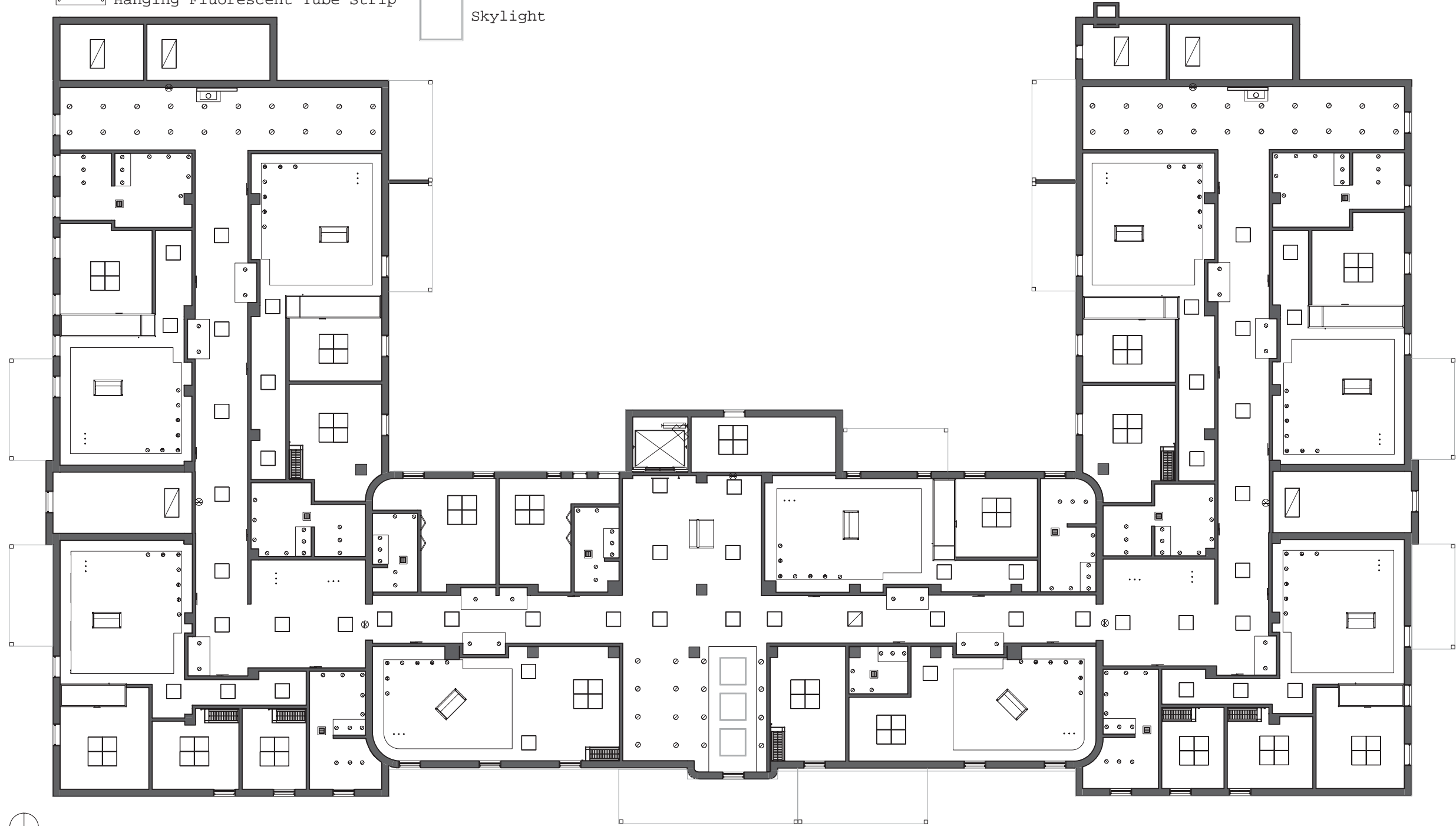

⊕ Reflected Ceiling Plan: Floor 3

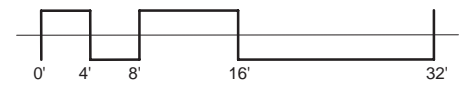





Detailed Spaces Diagram: Floor 1

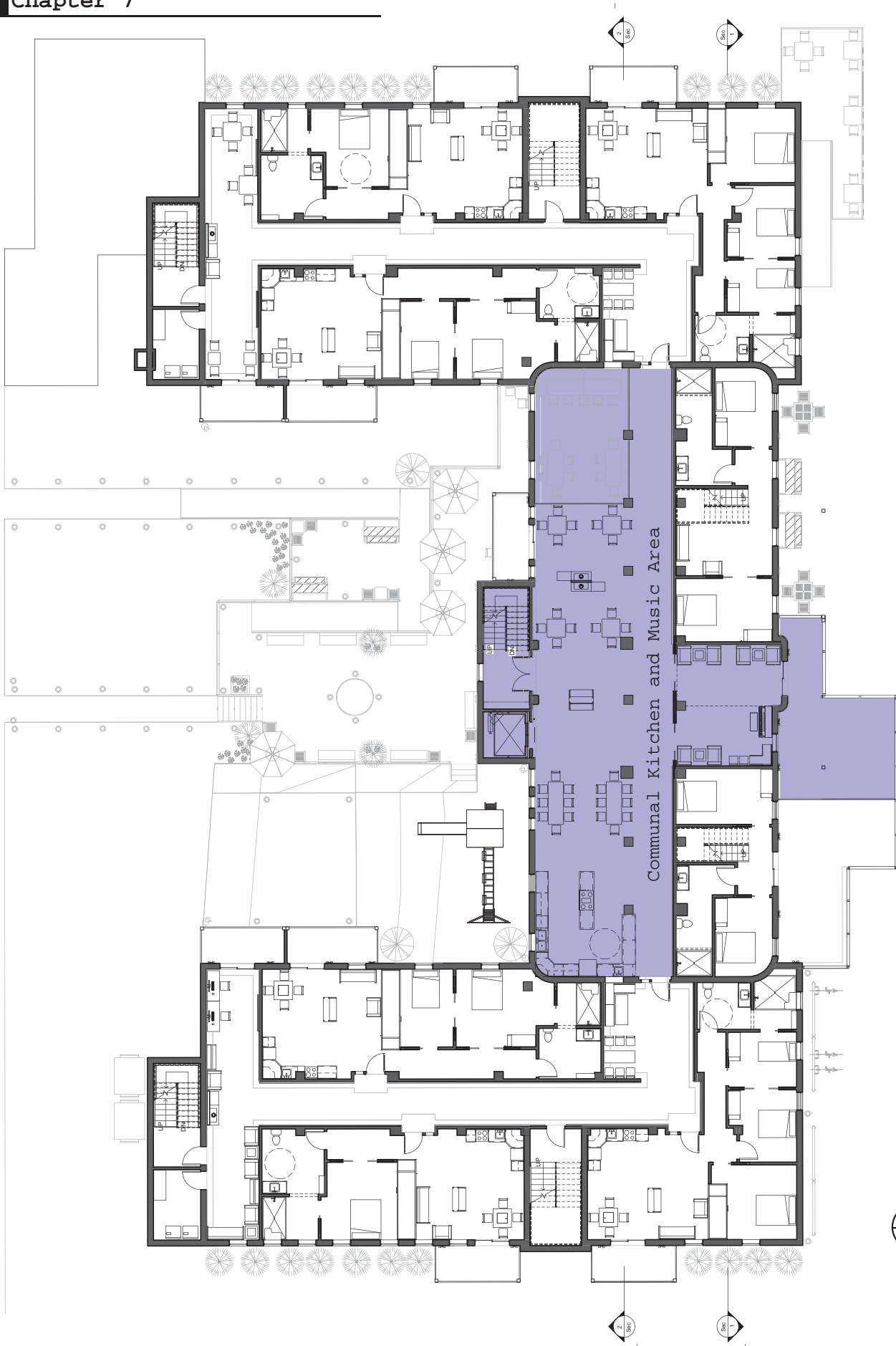

⊕ Detailed Spaces Diagram: Floor 2

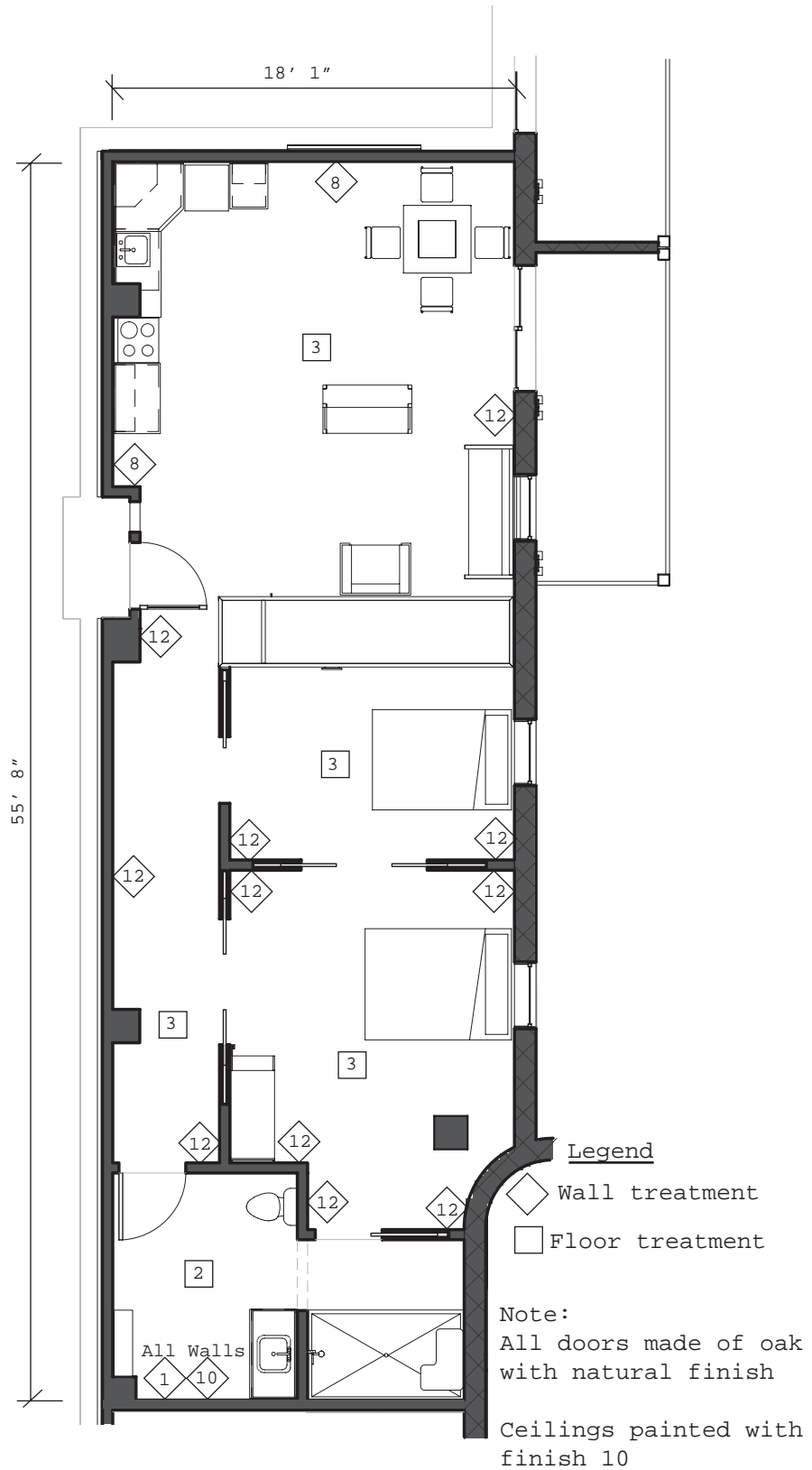

 Floor Plan

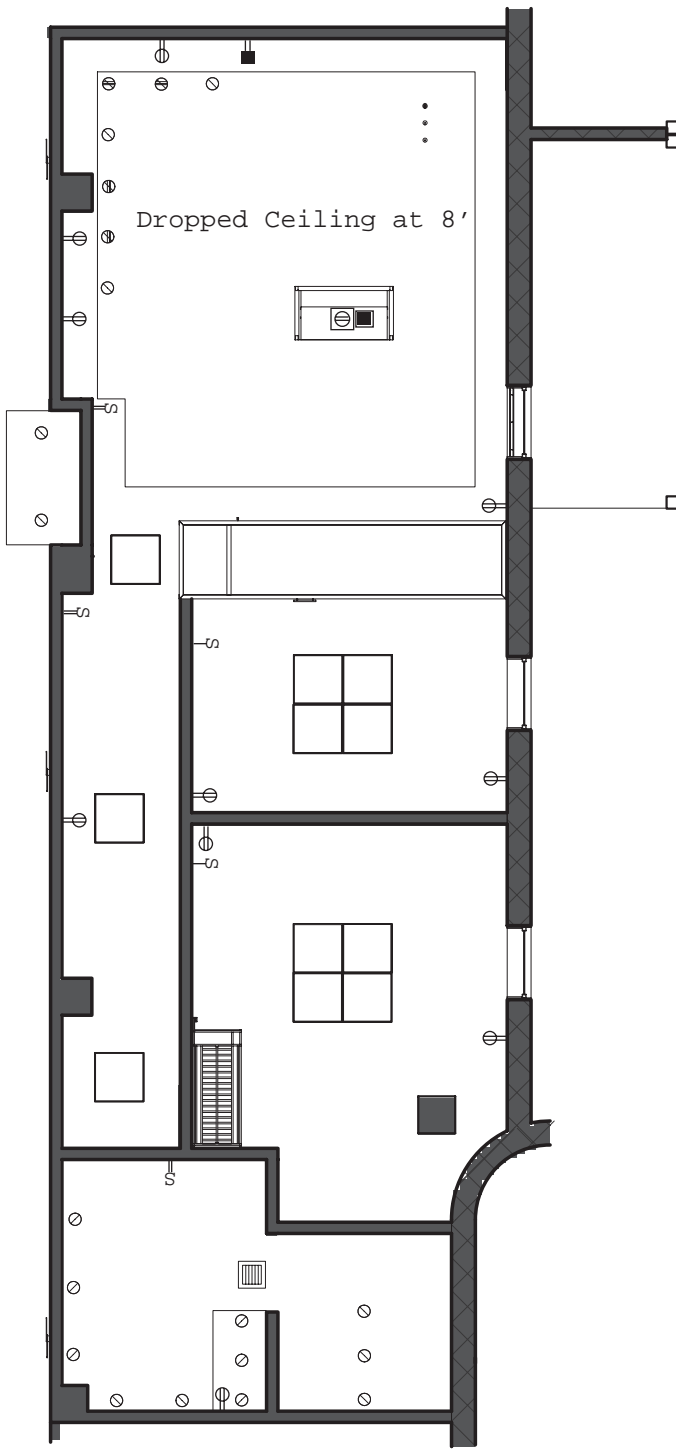

Reflected Ceiling Plan at 7'

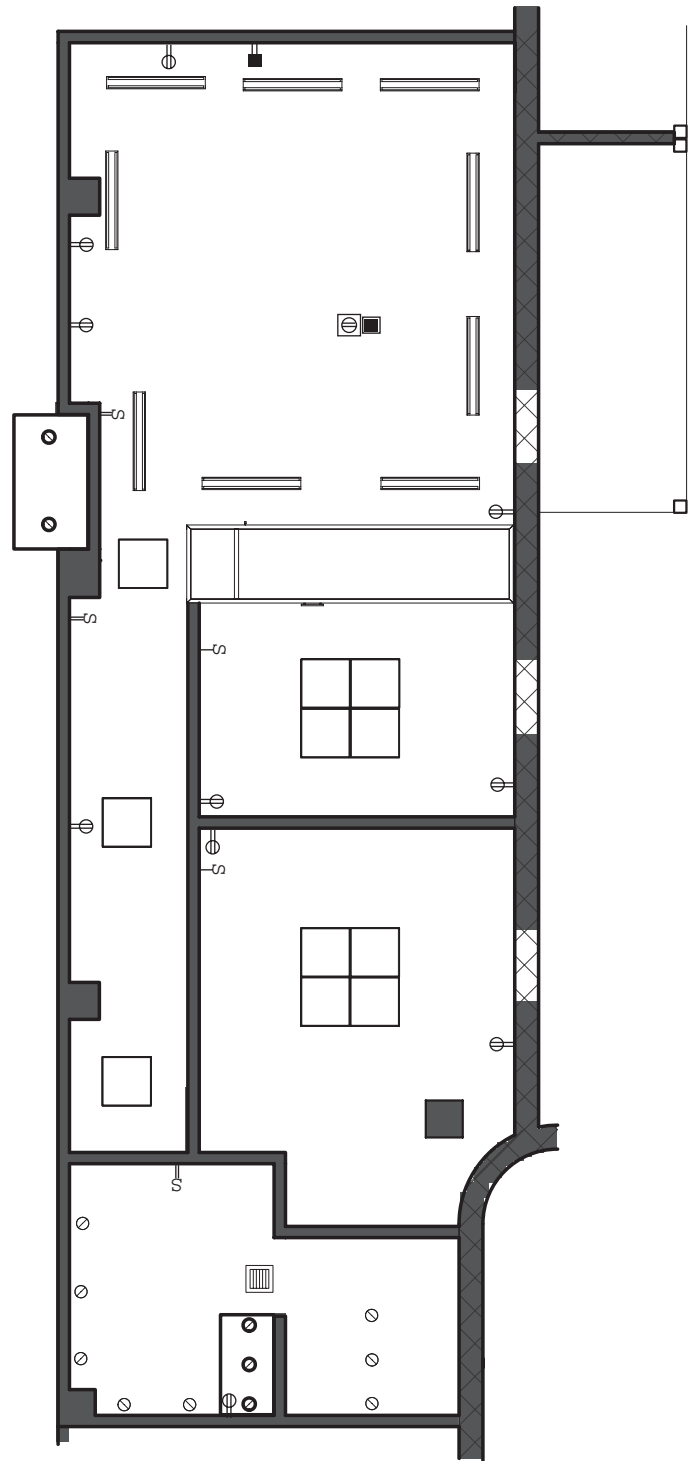

Reflected Ceiling Plan at 8' 9"

Legend:

○ 6" Recessed Downlight

□ Ceiling Light: 2'x2' Linear Box

▬ Surface Mounted Fluorescent Tube Strip

⊙ Cube Pendant Light

↔ Double Switch

↔ Single Switch

⊕ Double Outlet

■ TV & Phone Receptacle

⊕ Floor Double Outlet

■

7.2.2 ■ Furnishing and Finishes



- 1 - Olympia Tile: Ceramic Wall Tile (Pattern: Yukon Glossy) (Color: Mustard)
- 2 - Forbo: Marmoleum Flooring (Pattern: Real) (Color: Tobacco Leaf)
- 3 - Bruce: Hardwood Floors (Type: Solid Oak Hardwood) (Finish: BCC1100 Natural)
- 4 - DuPont: Zodiac Quartz Surfaces (Color: Cloud White)
- 5 - AGC Flat Glass North America: Acid-Etched Glass (Pattern: Matelux) (Color: Double-Sided Clear)
- 6 - Dow: Wood Stalk Bioproducts Strawboard (Finish: Natural)
- 7 - Brushed Stainless Steel
- 8 - Benjamin Moore Paint (Color: Sundried Tomato)
- 9 - DuPont: Zodiac Quartz Surfaces (Color: Space Black)
- 10 - BEHR Paint (Color: Polar Bear)
- 11 - White Birch (Finish: Natural)
- 12 - Benjamin Moore Paint (Color: Clay Beige)



GE 12.1 cu. ft. Top Freezer No-Frost Refrigerator in finish 7
L - 25"
W - 23.5"
H - 59.9"
Quantity: 1



Frigidaire Electric Range in finish 7
L - 26.7"
W - 24"
H - 47.8"
Quantity: 1



Wessan Drop In Single Bowl Stainless Steel Sink
L - 20"
W - 20"
H - 7"
Quantity: 1



Blanco Single Lever, Pull-out Kitchen Faucet, in finish 7
Quantity: 1

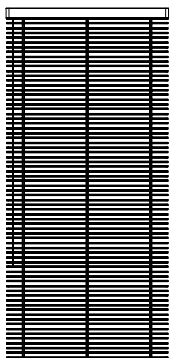

Wood Blinds in finish 11
W - 36"
H - 72"

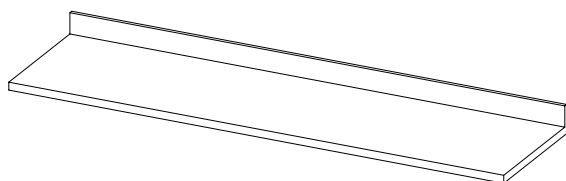

24" Depth Counter Top in finish 9

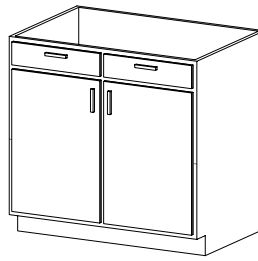

Base Cabinet - Double Door and 2 Drawer in finish 6
Hardware in finish 7
33" - Quantity 1
36" - Quantity 1

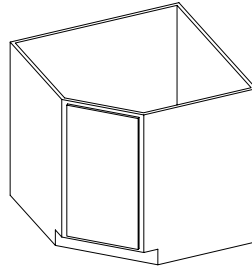

Base Cabinet - Corner Unit Angled in finish 6
Hardware in finish 7
Quantity: 1

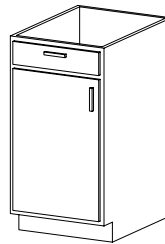

Base Cabinet - Single Door and Drawer in finish 6
Hardware in finish 7
18" - Quantity 1

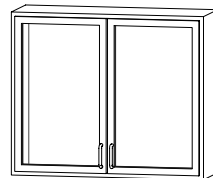

Wall Mounted Upper Cabinet - Double Door with Glass in finish 6 and 5
Hardware in finish 7
36" - Quantity 1

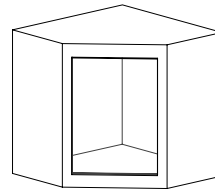

Wall Mounted Upper Cabinet - Corner Unit with Glass in finish 6 and 5
Hardware in finish 7
Quantity: 1

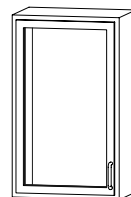

Wall Mounted Upper Cabinet - Single Door with Glass in finish 6 and 5
Hardware in finish 7
18" - Quantity 1



Ceralux Industries Inc.
Novara Lined 6L Toilet
Tank - White
L - 30.25"
W - 19.75"
H - 29"
Quantity: 1

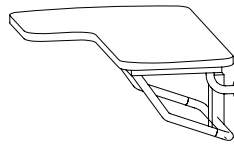

ADA Shower Seat
L - 36"
W - 36"
Quantity: 1



American Standard
Town Square Counter Top
Sink, White
L - 20"
W - 20"
H - 8.75"
Quantity: 1

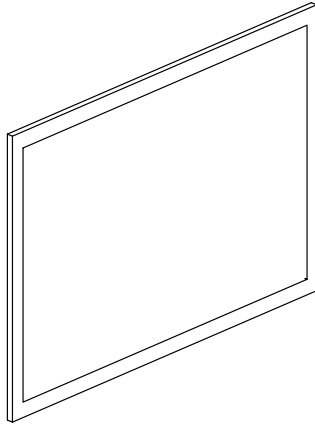

Vanity Mirror in finish 7
W - 48"
H - 36"
Quantity: 1



Hansgrohe Raindance E120
Handshower Set in
finish 7
Quantity: 1

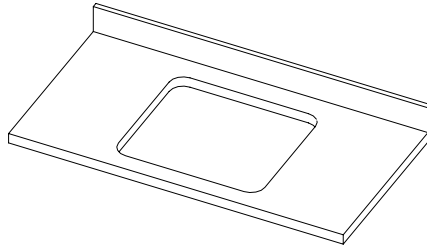

Vanity Counter Top
with Square Sink
Hole in finish 4

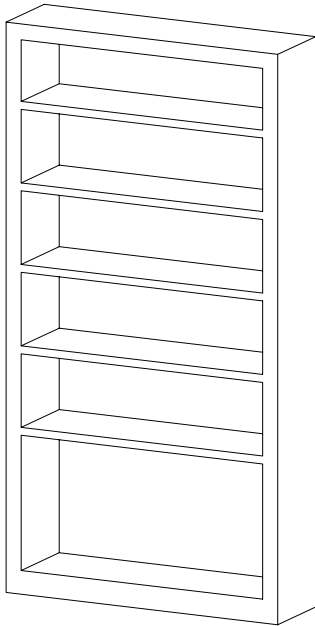

Bathroom
Shelving
in finish 6
L - 36"
W - 10"
H - 72"
Quantity: 1

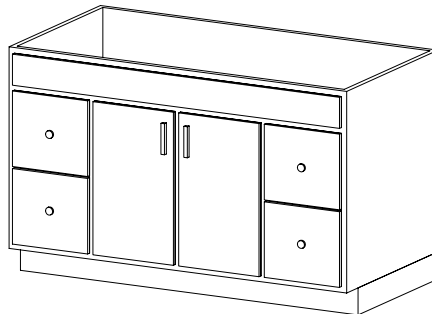

Vanity Cabinet - Double
Door and 4 Drawer in
finish 6
46.5" - Quantity 1

Custom Closet
in finish 6
L - 24"
W - 56"
H - 84"

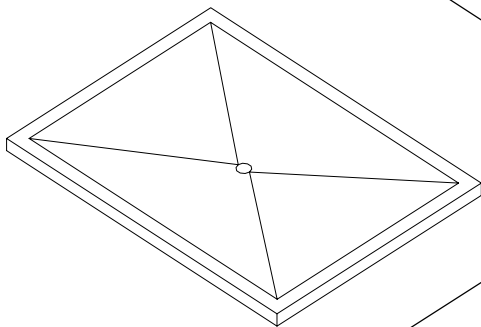
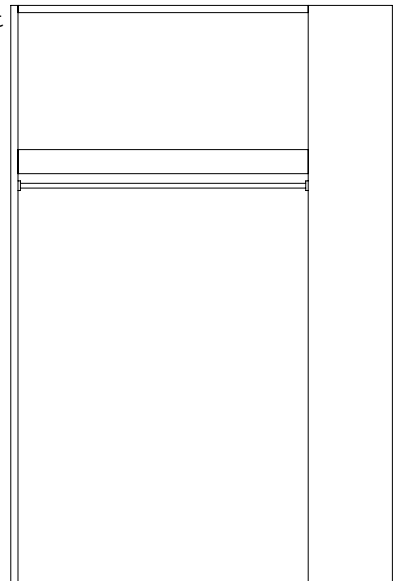

Shower Base with 1/2"
Beveled Curb
Quantity: 1



Front Perspective

Suite Built-In Feature: Size 1



Back Perspective

Note:

All structure
made of finish 6

All glass panels
made of finish 5

All hardware made
of finish 7

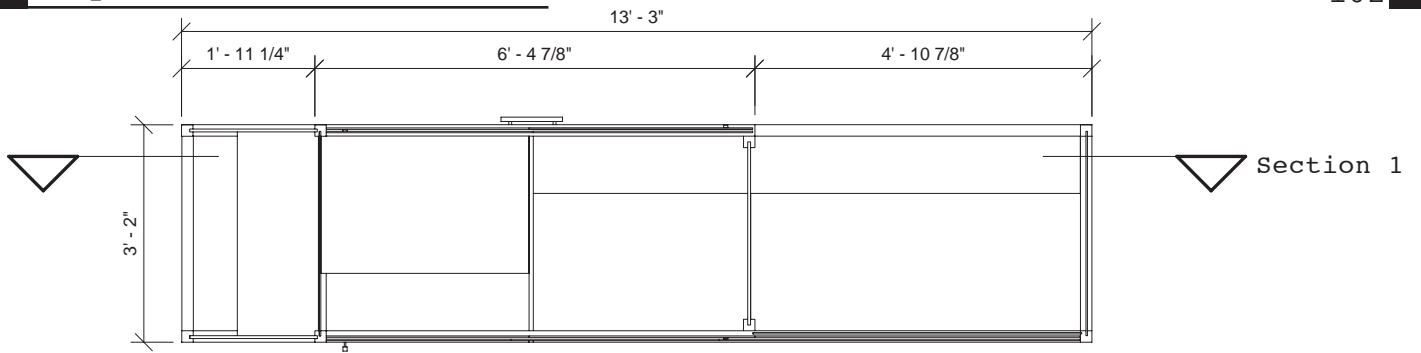

Plan: Cut at 4'

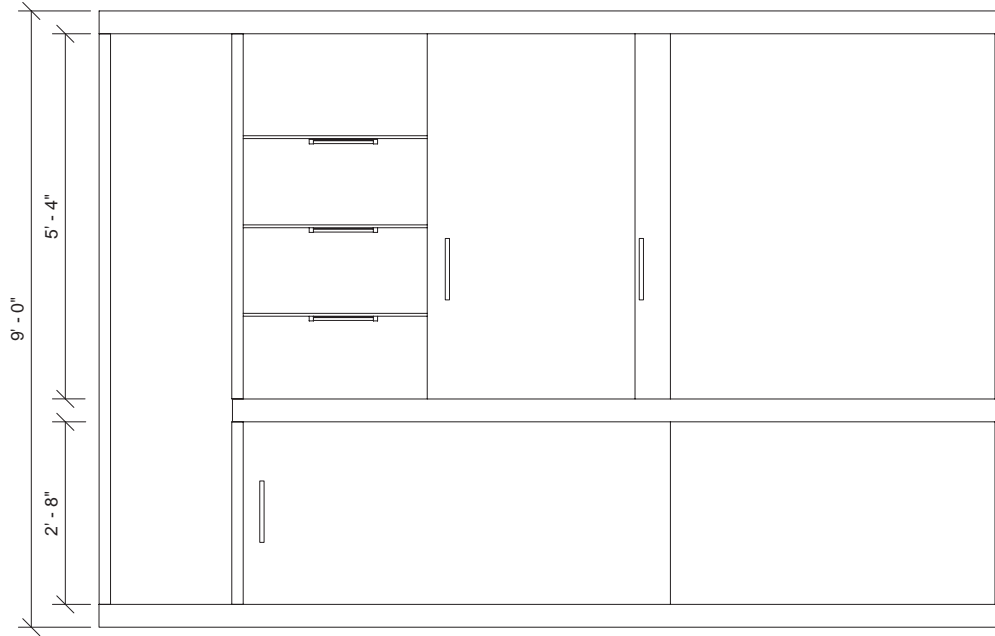

Front Elevation

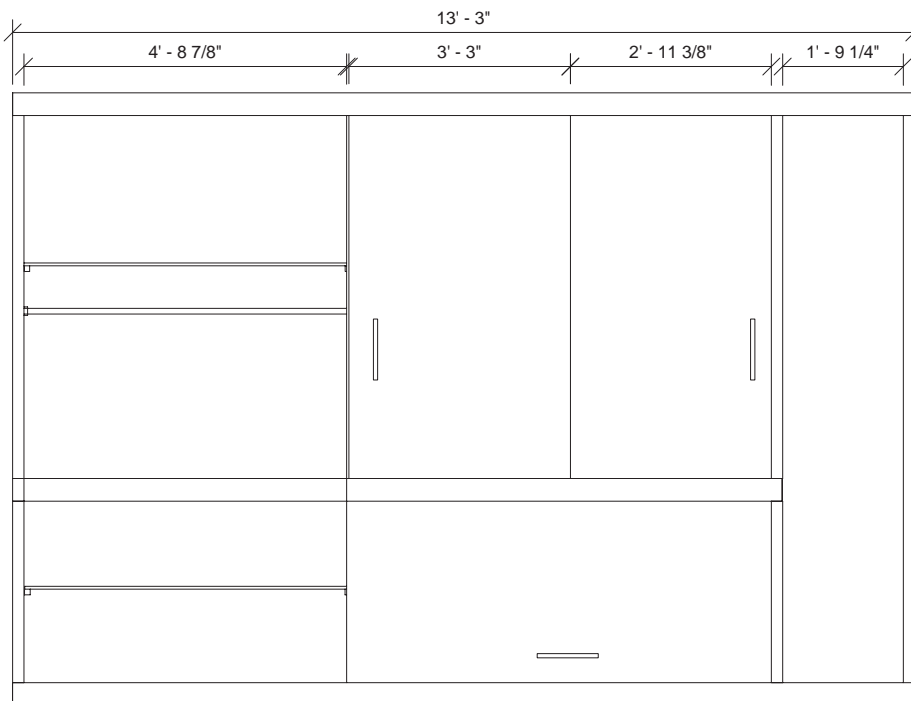

Back Elevation

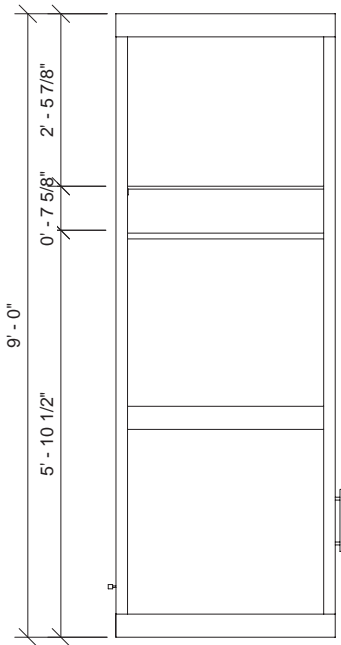

Left Elevation

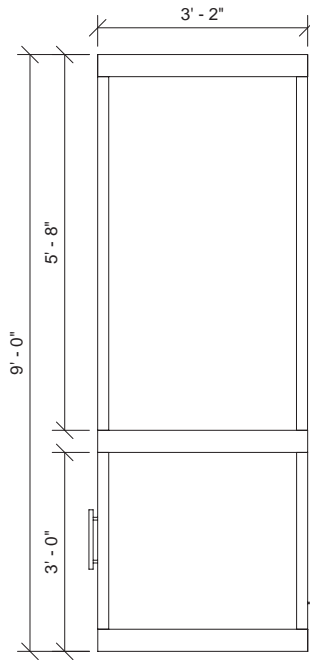

Right Elevation

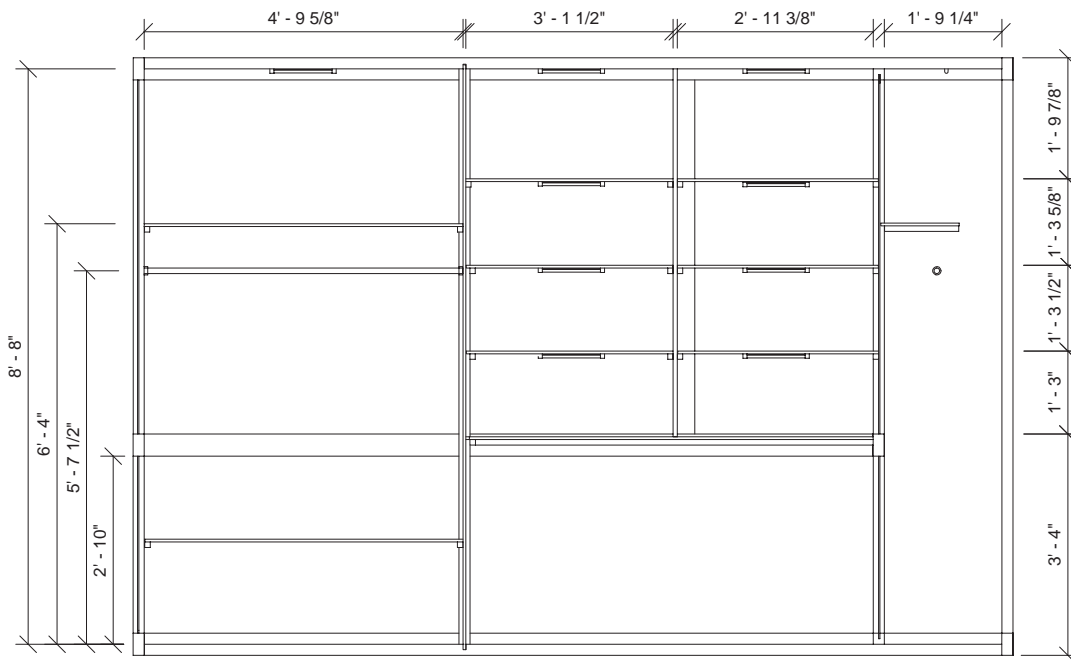

Section 1

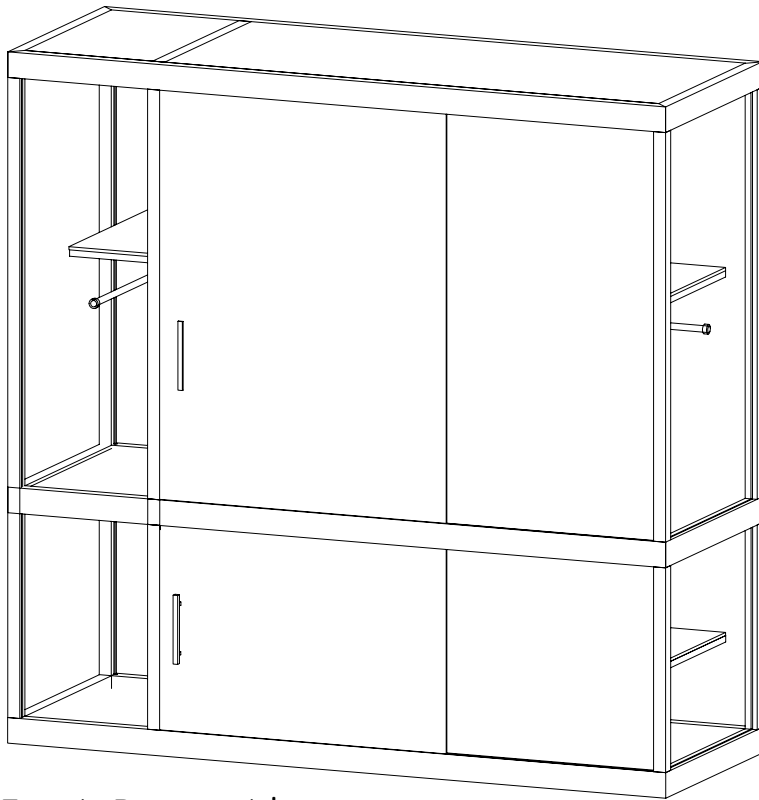

Front Perspective

Suite Built-In Feature: Size 2



Back Perspective

Note:

All structure
made of finish 6

All glass panels
made of finish 5

All hardware made
of finish 7

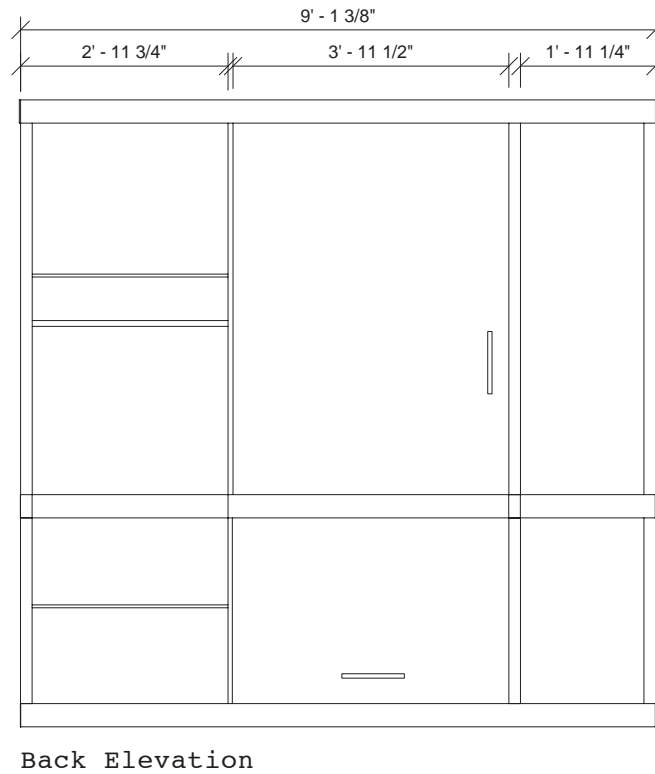
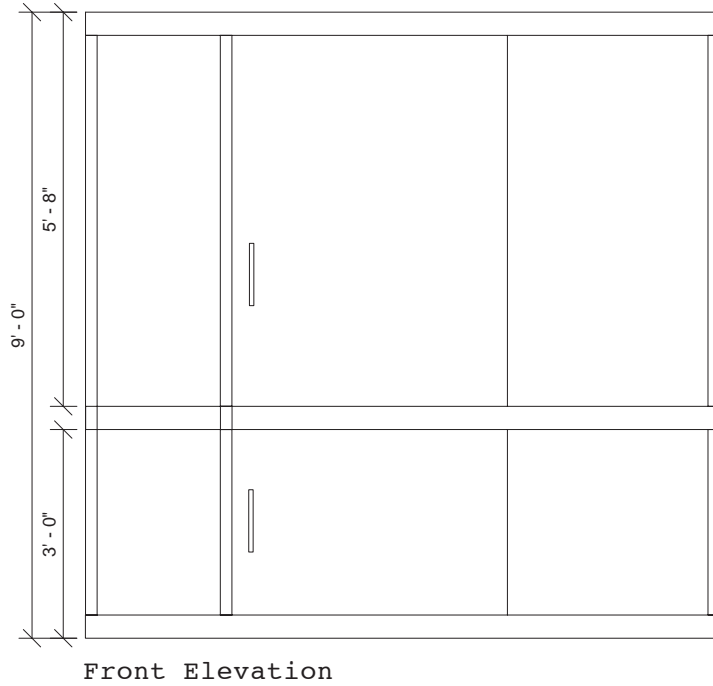
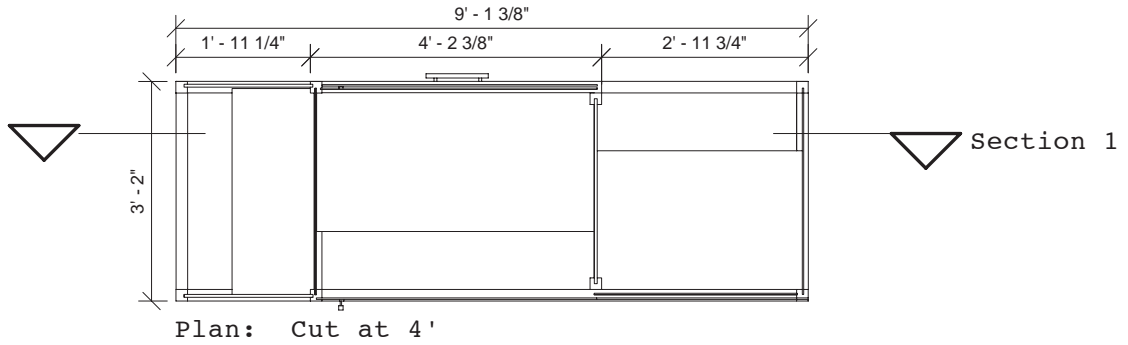

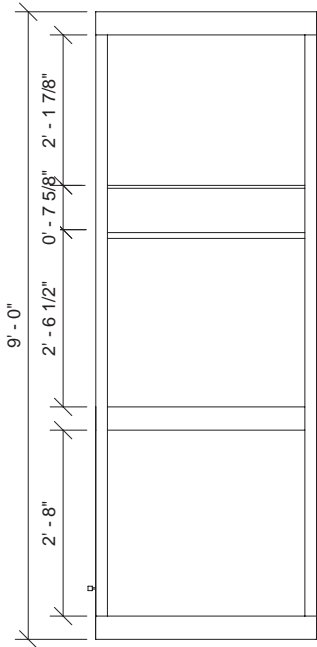

Left Elevation

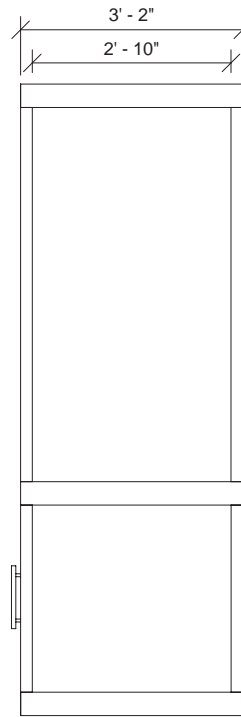

Right Elevation

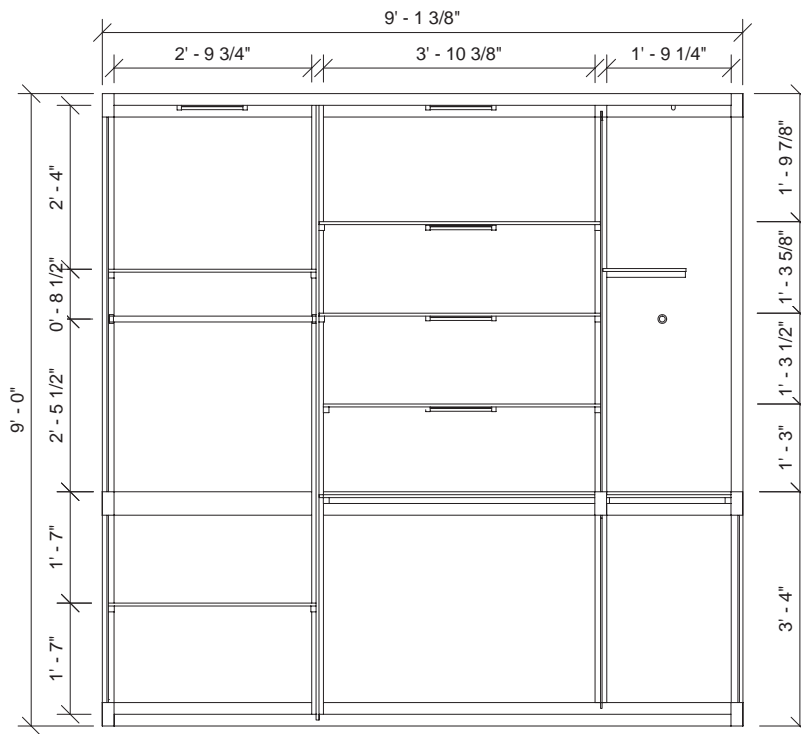

Section 1

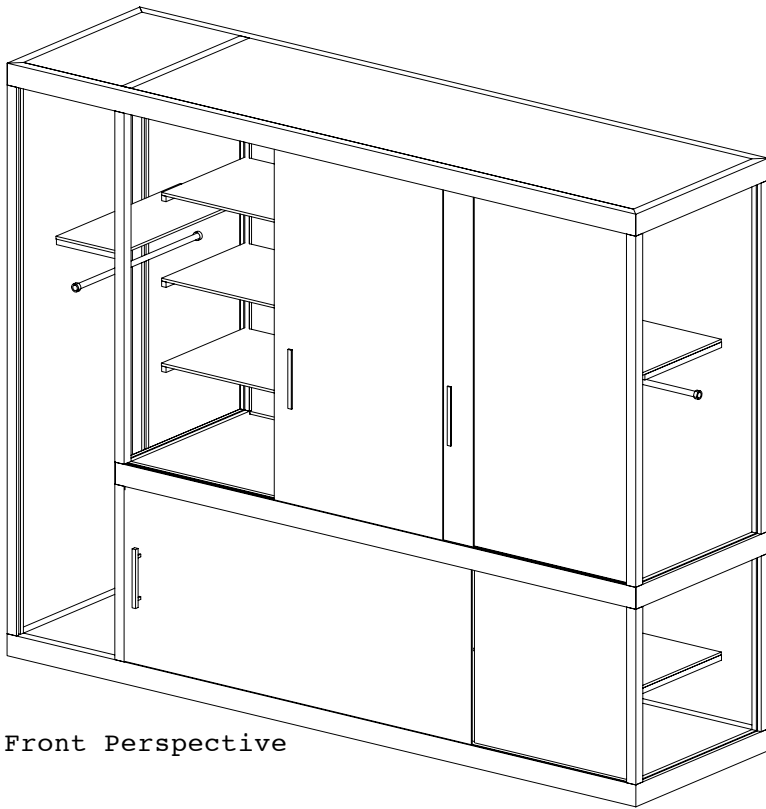

Front Perspective

Suite Built-In Feature: Size 3

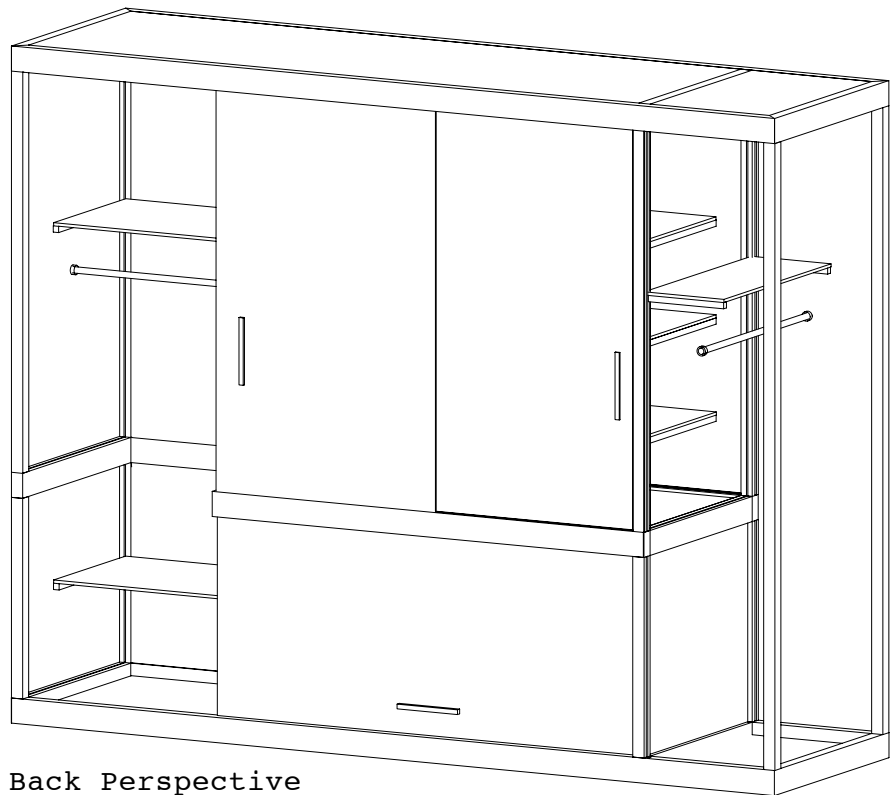

Back Perspective

Note:

All structure
made of finish 6

All glass panels
made of finish 5

All hardware made
of finish 7

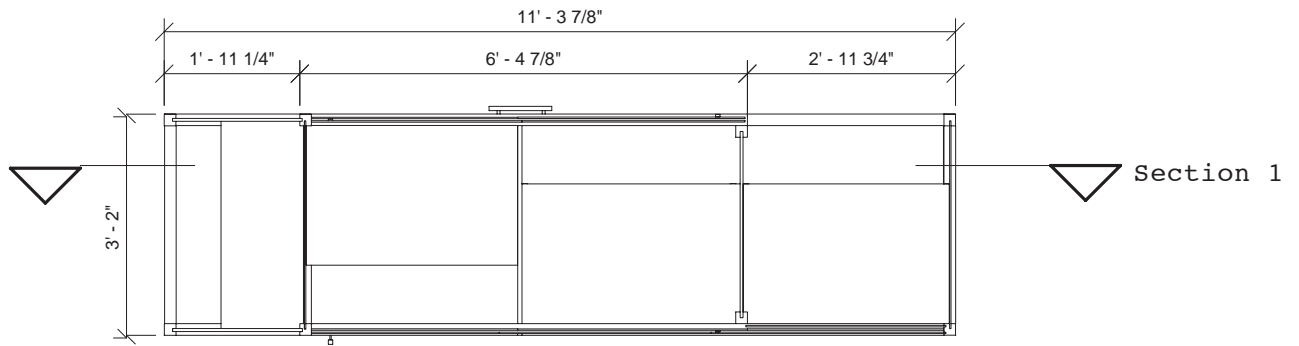

Plan: Cut at 4'

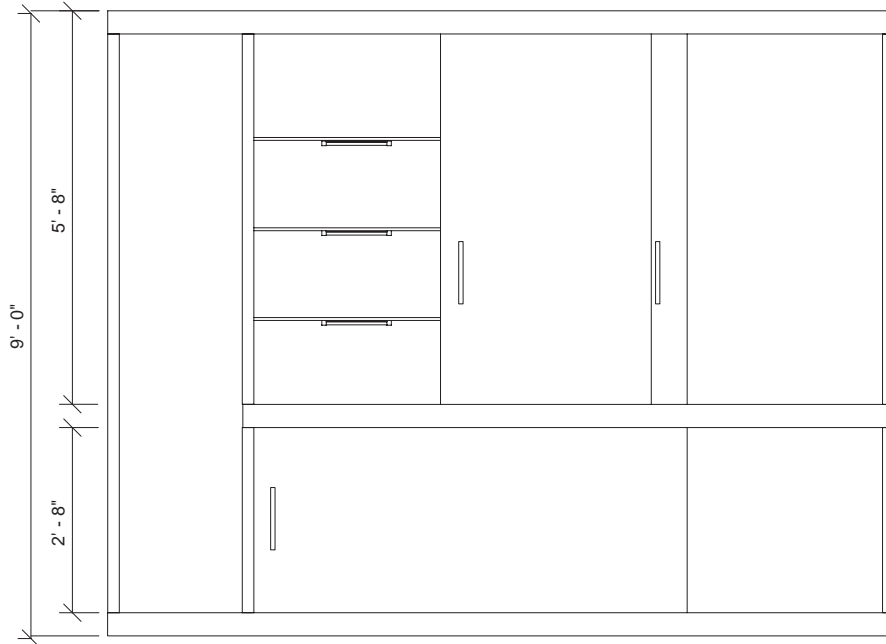

Front Elevation

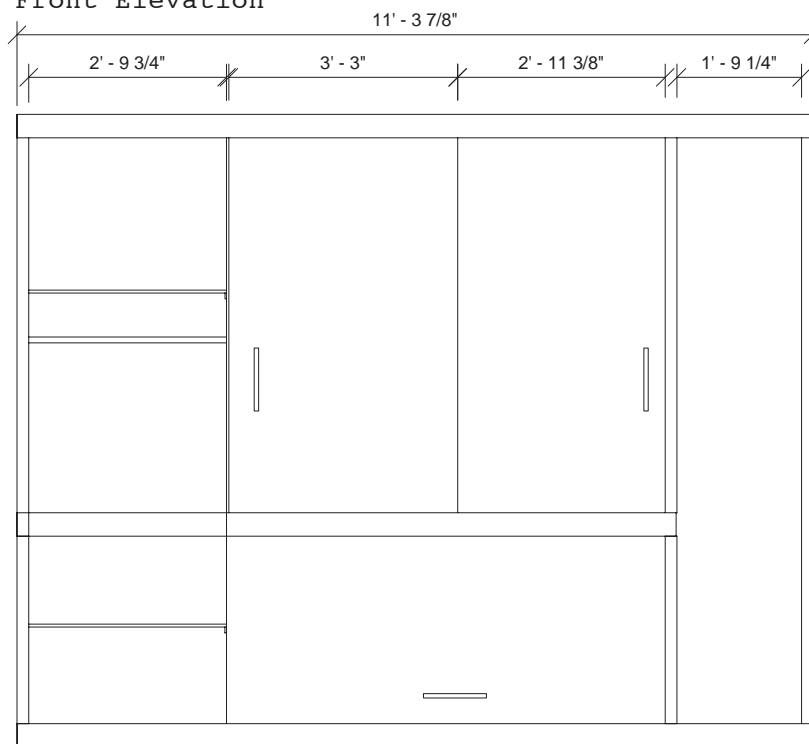

Back Elevation

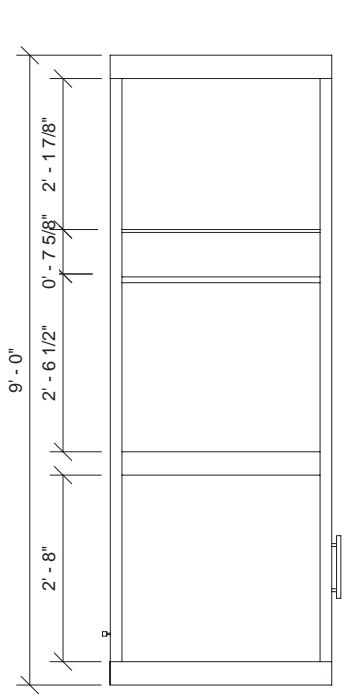

Left Elevation

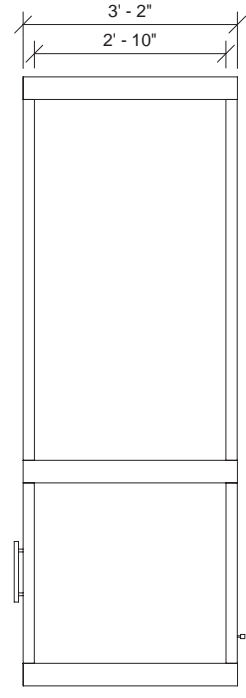

Right Elevation

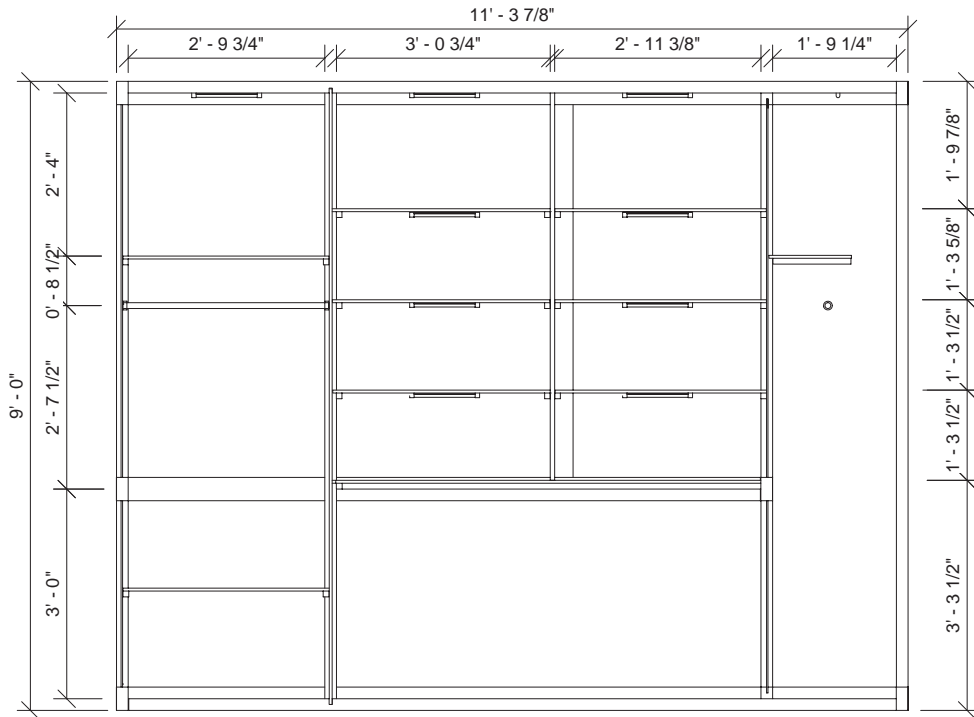

Section 1



Suite 'Hearth' Display Feature

Note:

All structure
made of finish 6

All glass panels
made of finish 5

All hardware made
of finish 7

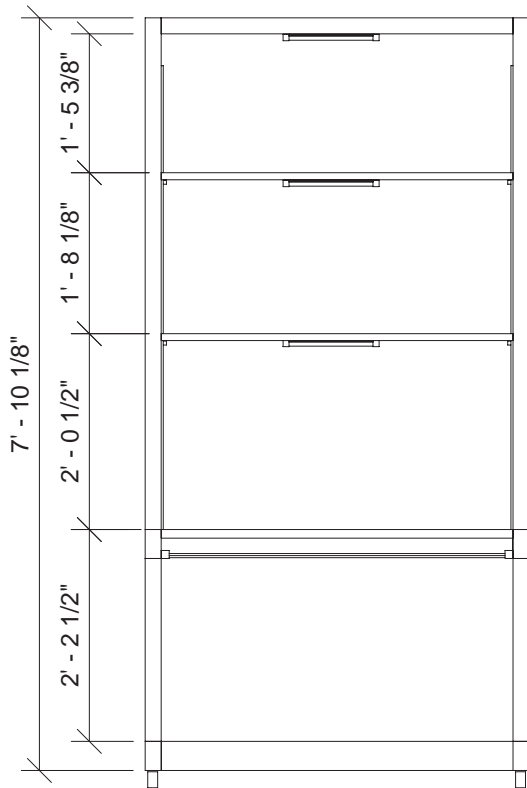
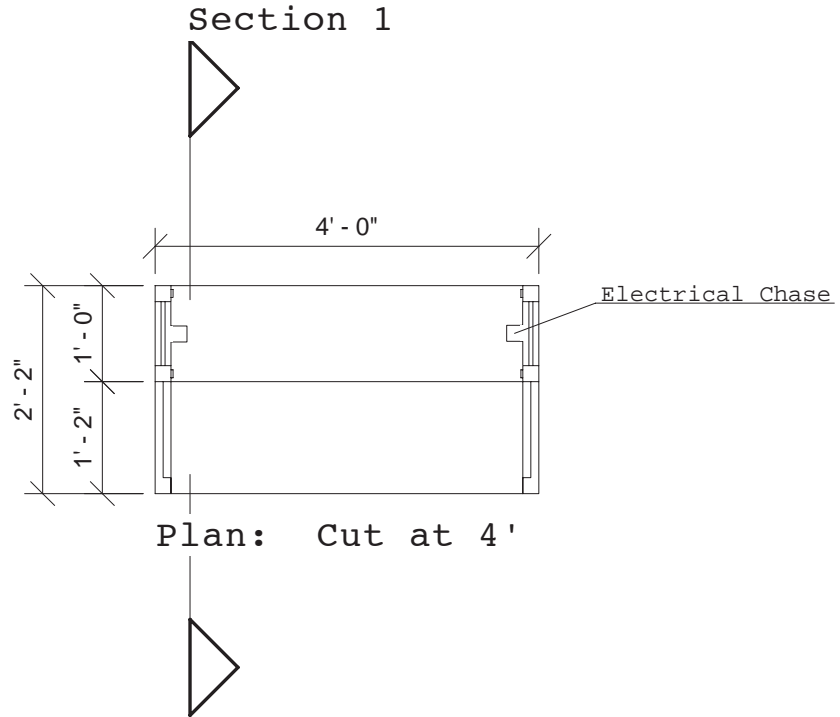

Front Elevation

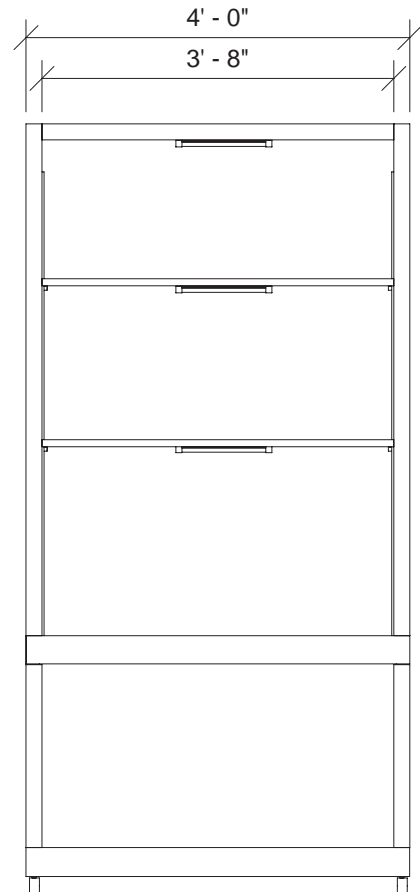

Back Elevation

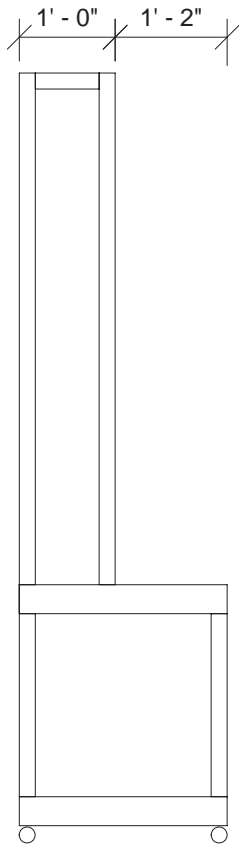

Left Elevation

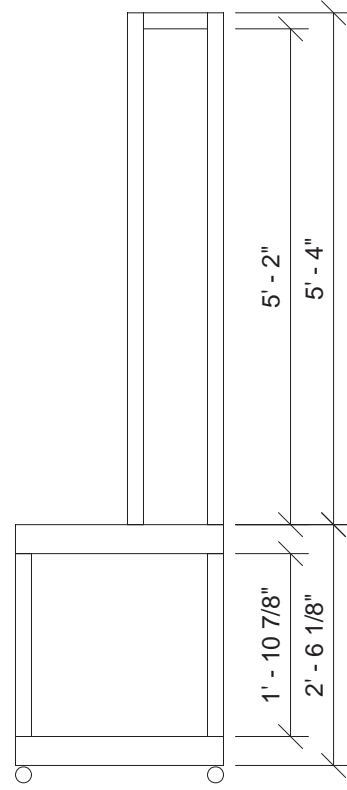

Right Elevation

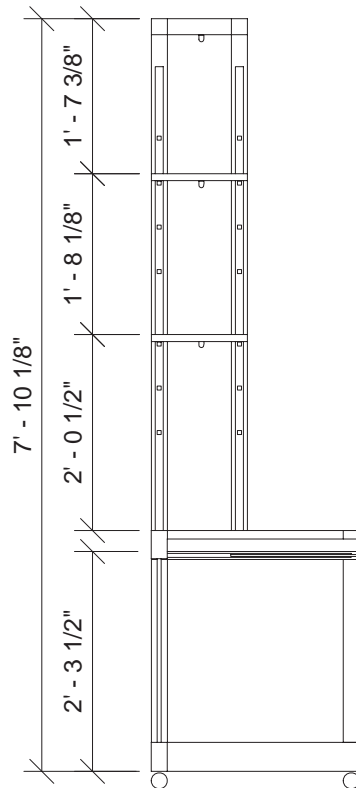

Section 1

7.2.3 ■ Perspectives



Suite Kitchen/Dining



Suite Living



Suite Washroom

7.3 ■ Gaming Room Drawings

7.3.1 ■ Formal Drawings

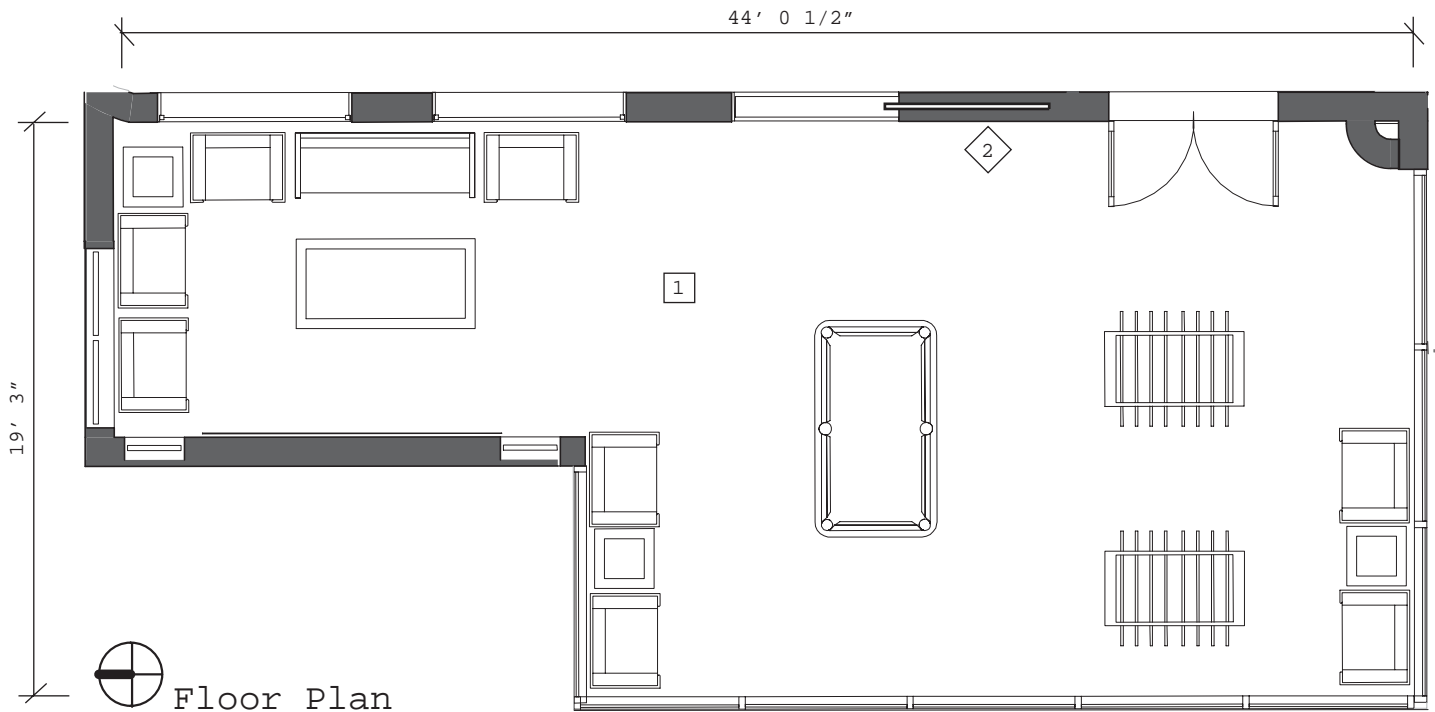

⊕ Floor Plan

Legend

- ◇ Wall treatment
- Floor treatment

Note:

All doors made of oak with natural finish

Ceilings painted with finish 8

7.3.2 ■ Furnishing and Finishes



- 1 - Bruce: Hardwood Floors (Type: Solid Oak Hardwood) (Finish: BCC1100 Natural)
- 2 - Existing Brick
- 3 - Dow: Wood Stalk Bioproducts Strawboard (Finish: Natural)
- 4 - Maharam: Upholstry (Pattern: Alley-Force Field) (Color: Fortress)
- 5 - AGC Flat Glass North America: Acid-Etched Glass (Pattern: Matelux) (Color: Double-Sided Clear)
- 6 - Brushed Stainless Steel
- 7 - Maharam: Upholstry (Pattern: Milestone) (Color: Daffodil)
- 8 - BEHR Paint (Color: Polar Bear)
- 9 - White Birch (Finish: Natural)

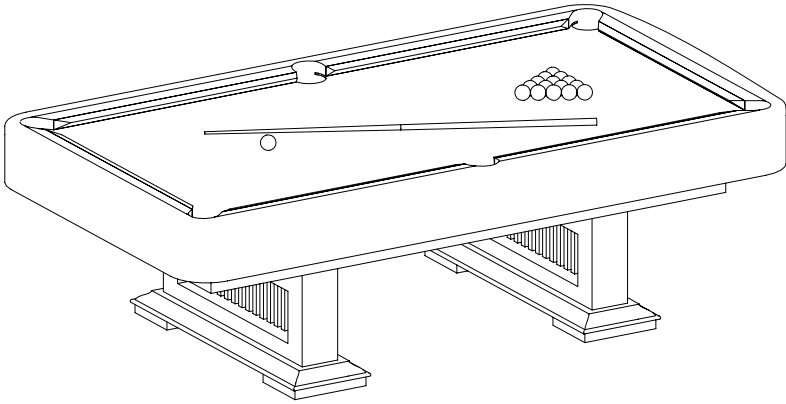

Billiard Table
L - 96"
W - 48"
H - 30"
Quantity: 1



Foosball Table
L - 48"
W - 24"
H - 32"
Quantity: 2

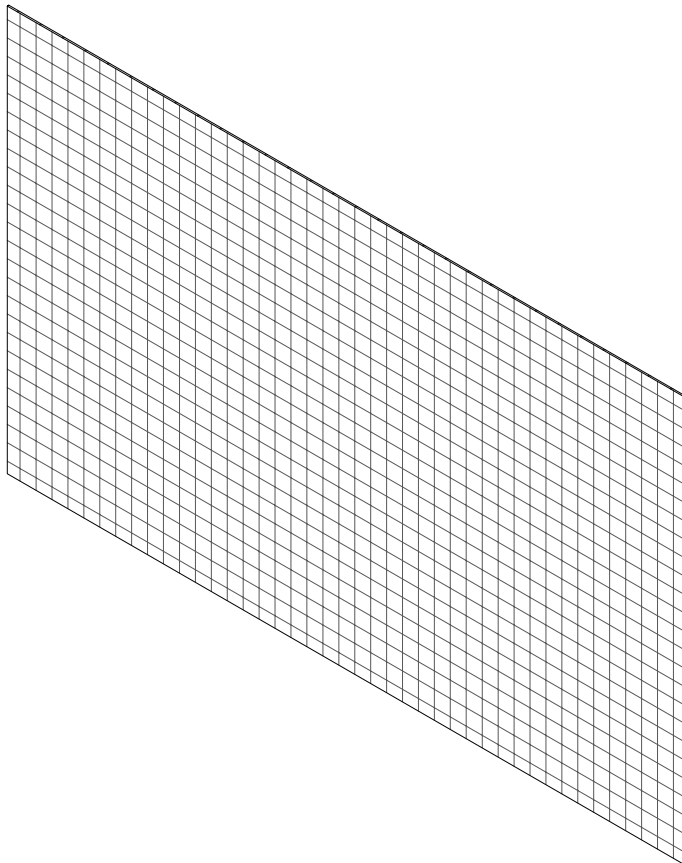

Entertainment
Projection Screen
W - 108"
H - 72"
Quantity: 1

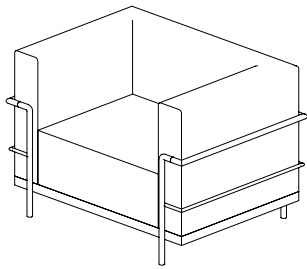

Corbusier Chair
in finish 4 and 6
Quantity: 4
and
in finish 7 and 6
Quantity: 4
L - 27.6"
W - 30"
H - 17"

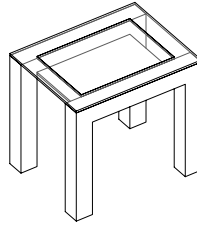

Custom Coffee Table
in finish 5 and 3
24"x24"x24" - Quantity 1
72"x24"x24" - Quantity: 3

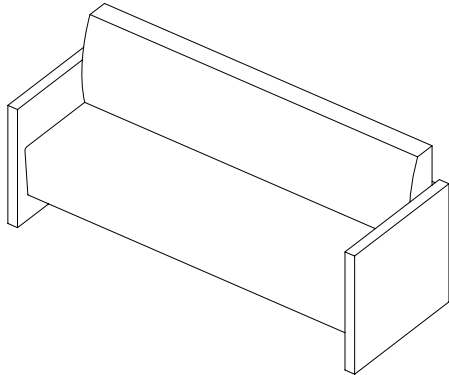

Custom Sofa
in finish 4
L - 72"
W - 26"
H - 17"
Quantity: 1

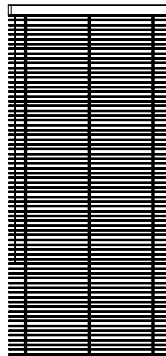

Wood Blinds in
finish 9
W - 36"
H - 72"

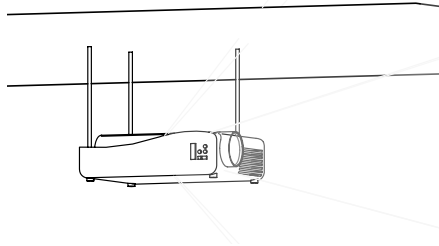

Ceiling Based Projector
Quantity: 1

7.3.3 ■ Perspectives



Gaming Room

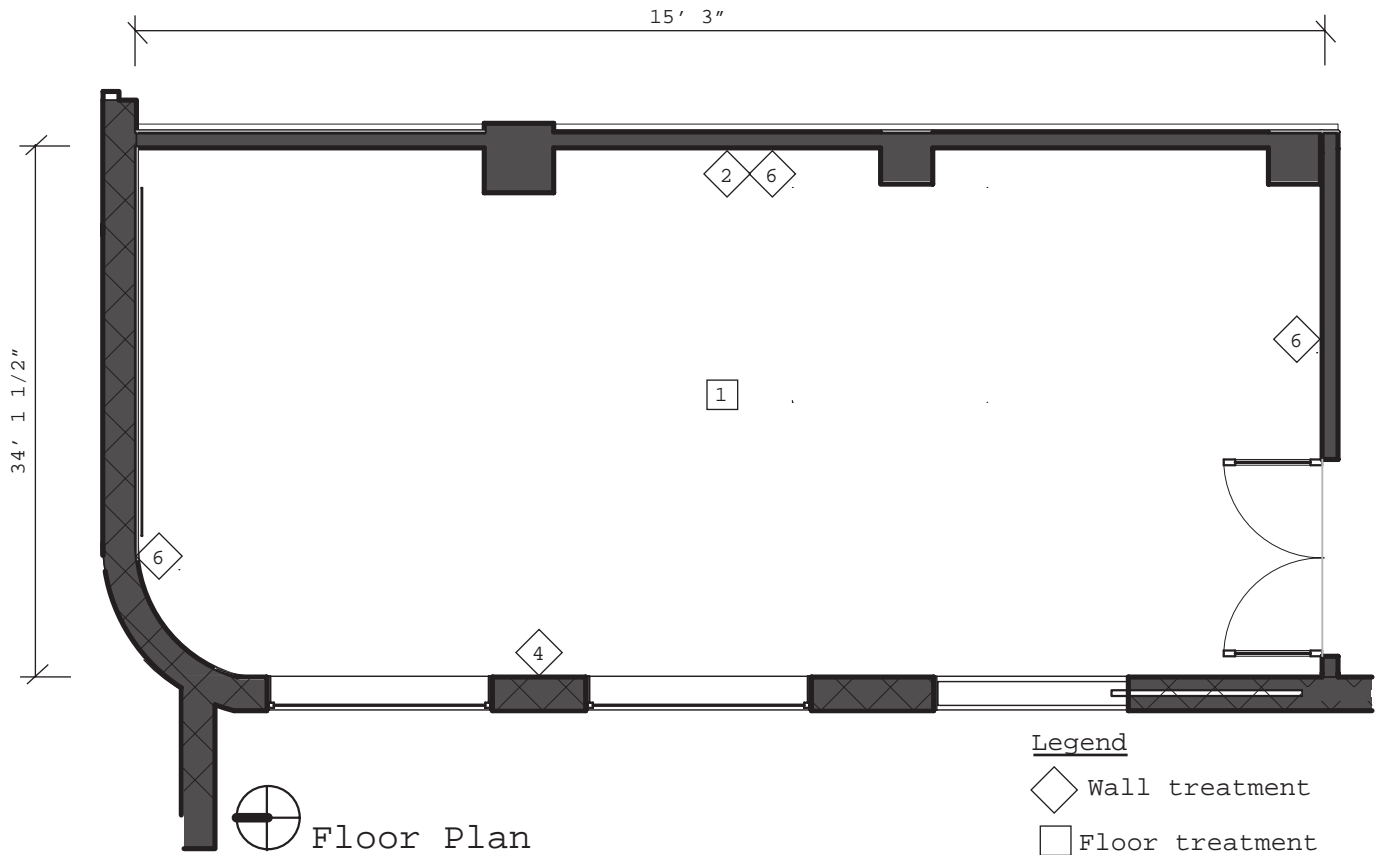

Note:
All doors made of oak
with natural finish

Ceilings painted with
finish 3

7.4.2 ■ Furnishing and Finishes

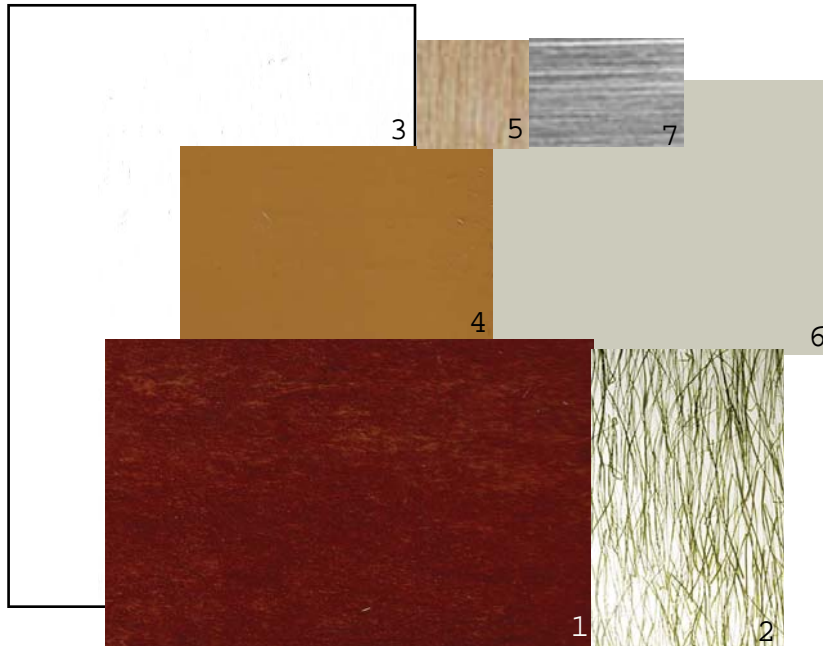

- 1 - Forbo: Marmoleum Flooring (Pattern: Dual) (Color: Brick)
- 2 - 3Form Pressed Glass (Bear Grass)
- 3 - BEHR Paint (Color: Polar Bear)
- 4 - Benjamin Moore Paint (Color: Autumn Gold)
- 5 - White Birch (Finish: Natural)
- 6 - Benjamin Moore Paint (Color: Ballet White)
- 7 - Brushed Stainless Steel

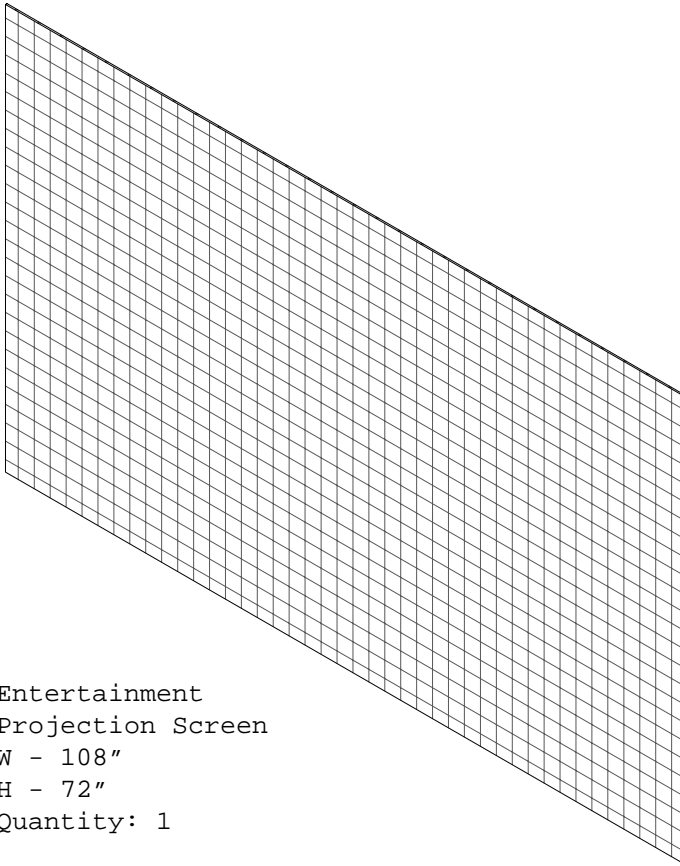

Entertainment
Projection Screen
W - 108"
H - 72"
Quantity: 1

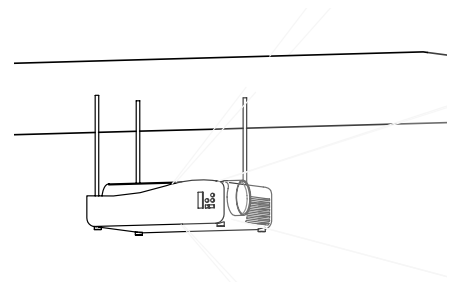

Ceiling Based Projector
Quantity: 1

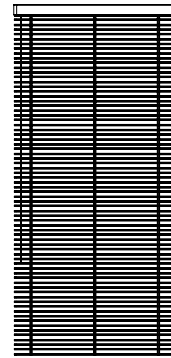

Wood Blinds
in finish 6
W - 36"
H - 72"

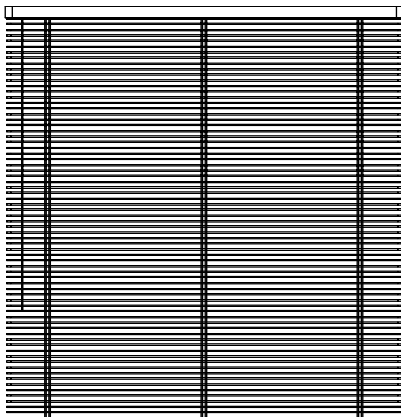

Robust custom wood blinds with fasteners to bottom that
aid in the protection of plexiglass windows at ground
level
W - 72"
H - 80"
Quantity: 2

7.4.3 ■ Perspectives

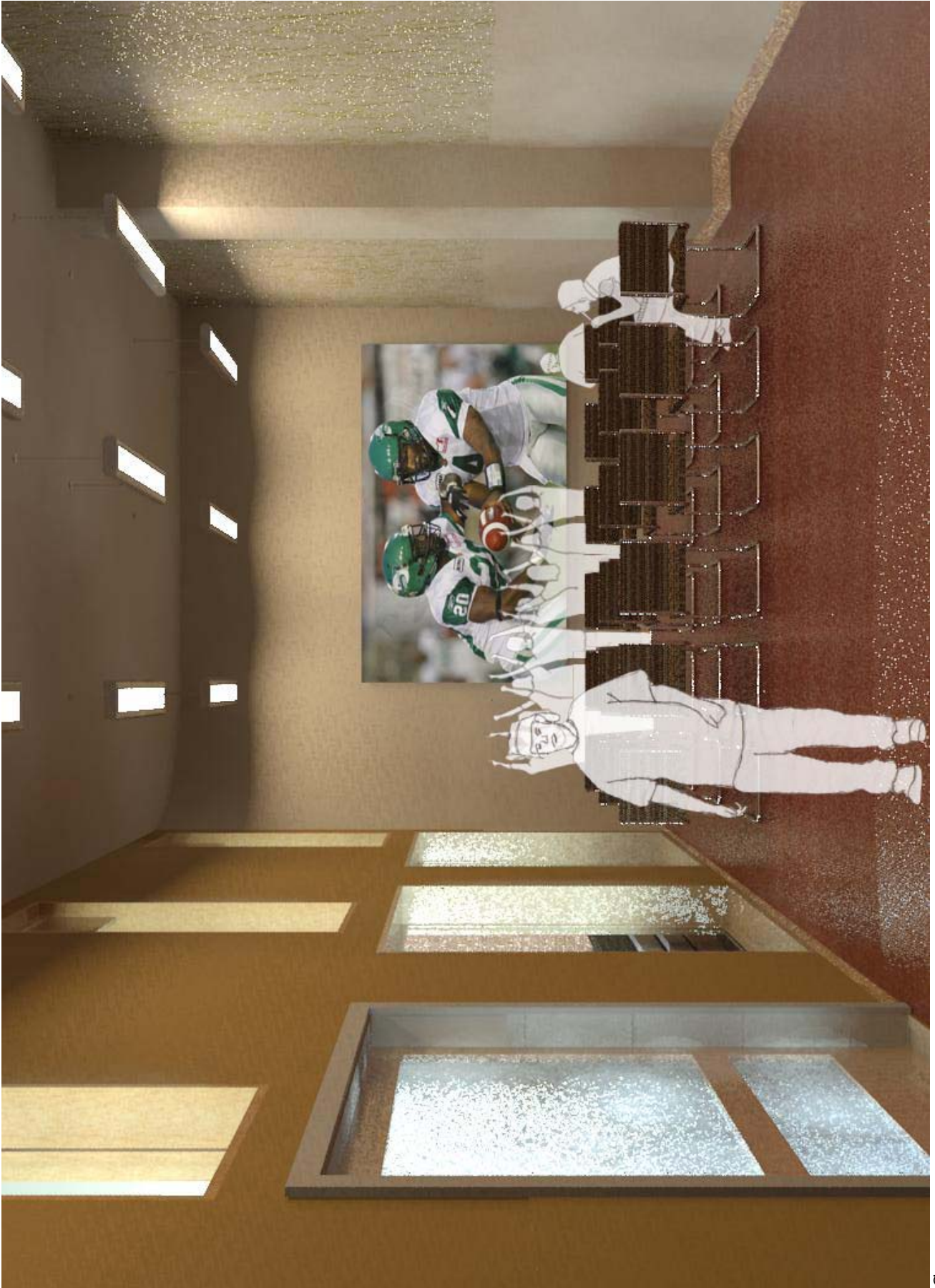

Gym

7.5 ■ Exercise Space Drawings

7.5.1 ■ Formal Drawings

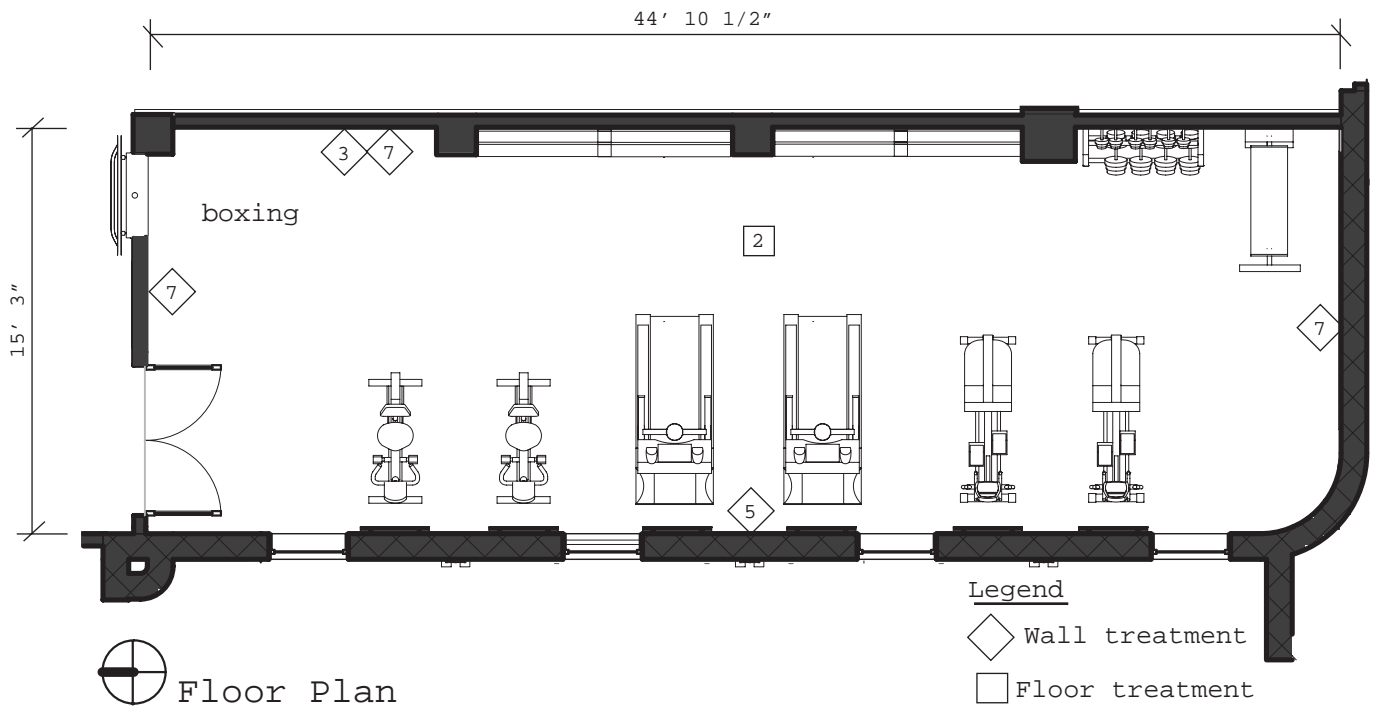

7.5.2 ■ Furnishing and Finishes

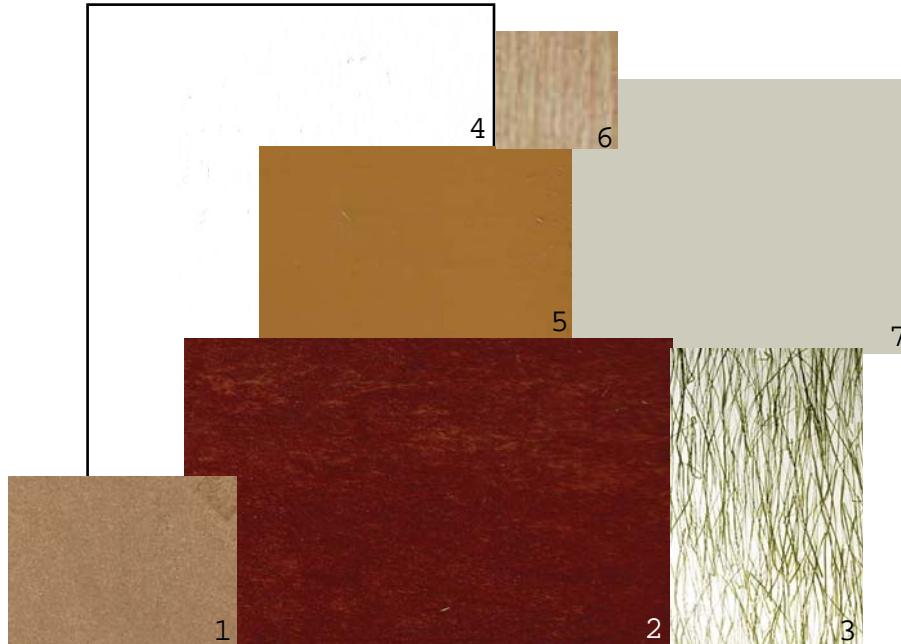

- 1 - Dow: Wood Stalk Bioproducts Strawboard (Finish: Natural)
- 2 - Forbo: Marmoleum Flooring (Pattern: Dual) (Color: Brick)
- 3 - 3Form Pressed Glass (Bear Grass)
- 4 - BEHR Paint (Color: Polar Bear)
- 5 - Benjamin Moore Paint (Color: Autumn Gold)
- 6 - White Birch (Finish: Natural)
- 7 - Benjamin Moore Paint (Color: Ballet White)

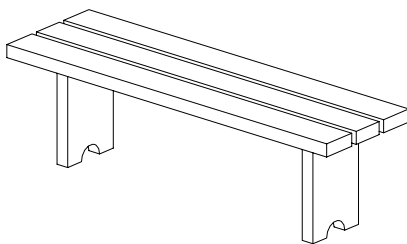

Custom Bench in
finish 1
L - 108"
W - 18"
H - 18"
Quantity: 2

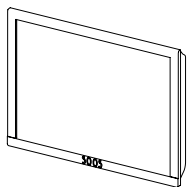

36" Flat Screen Plasma
Television
Quantity: 6

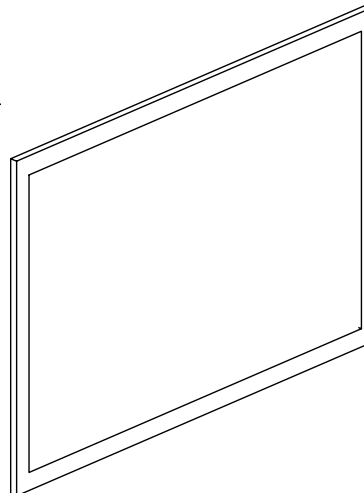

Mirror with
Stainless Steel
Frame
W - 129"
H - 96"
Quantity: 1

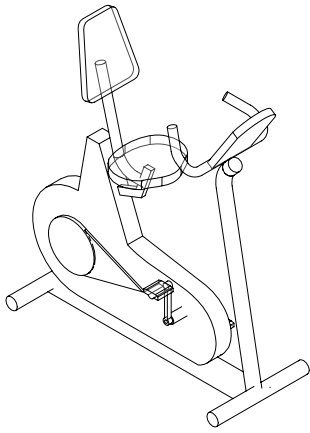

Stationary Bike
L - 82"
W - 24"
H - 30"
Quantity: 2

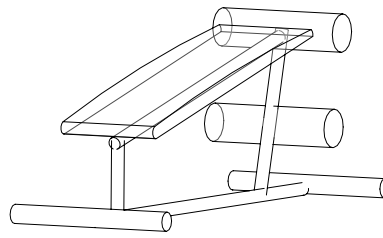

Free Weight Bench
L - 48"
W - 24"
H - 15"
Quantity: 1

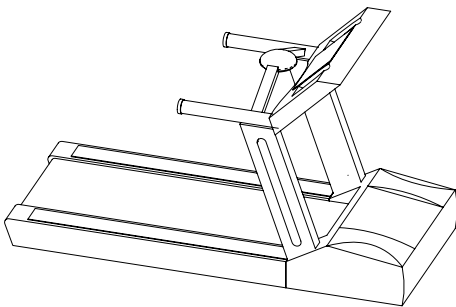

Treadmill
L - 68"
W - 26"
H - 42"
Quantity: 2

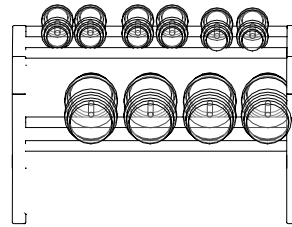

Free Weight Set
Quantity: 1

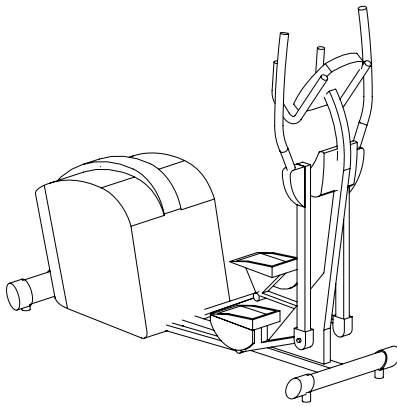

Elliptical Trainer
L - 56"
W - 30"
H - 66"
Quantity: 2



Century Heavy Bag/
Speed Bag Platform
L - 84"
W - 72"
H - 96"
Quantity: 1

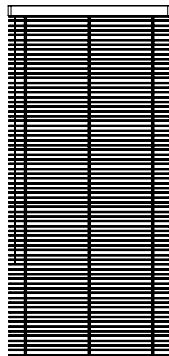

Wood Blinds
in finish 6
W - 36"
H - 72"

7.5.3 ■ Perspectives



Exercise Space

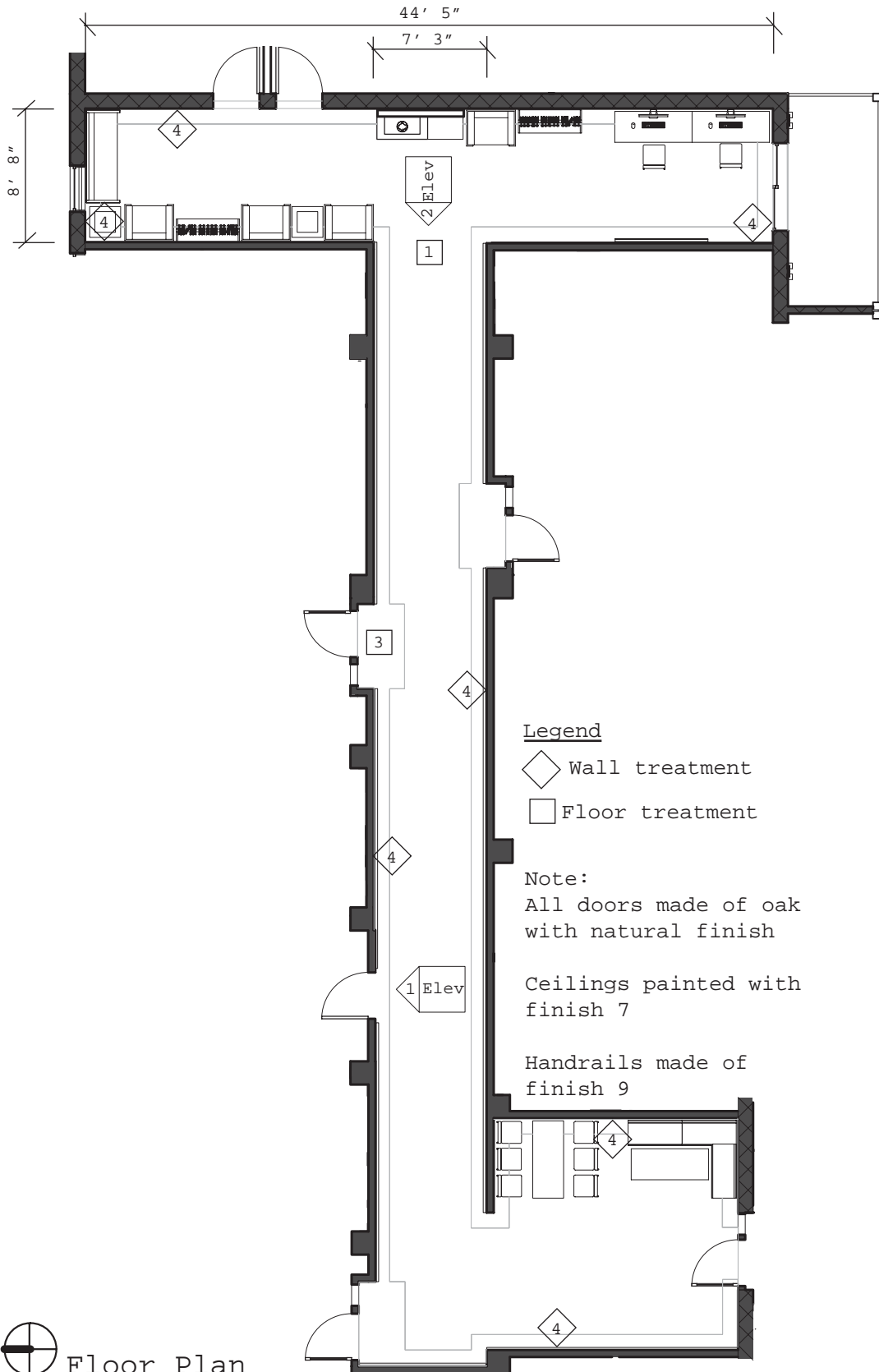

 Floor Plan

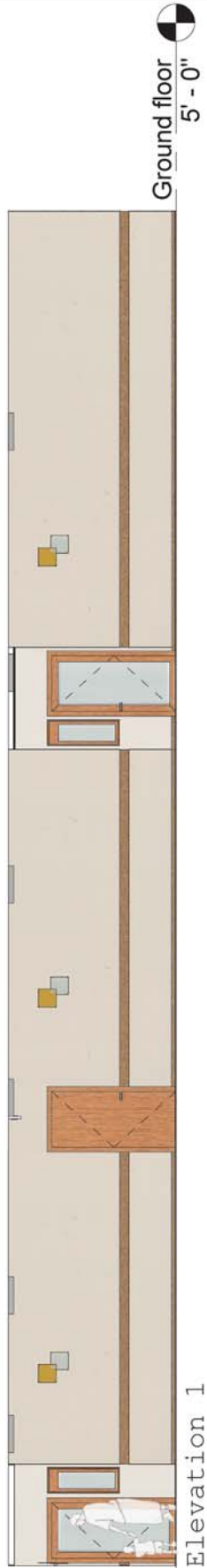

7.6.2 ■ Furnishing and Finishes



- 1 - Forbo: Marmoleum Flooring (Pattern: Real) (Color: Tobacco Leaf)
- 2 - Red Brick
- 3 - Forbo: Marmoleum Flooring (Pattern: Real Authentic) (Color: Van Gogh)
- 4 - Benjamin Moore Paint (Color: Clay Beige)
- 5 - DuPont: Zodiac Quartz Surfaces (Color: Space Black)
- 6 - Maharam: Upholstry (Pattern: Milestone) (Color: Daffodil)
- 7 - BEHR Paint (Color: Polar Bear)
- 8 - White Birch (Finish: Natural)
- 9 - Dow: Wood Stalk Bioproducts Strawboard (Finish: Natural)
- 10 - AGC Flat Glass North America: Acid-Etched Glass (Pattern: Matelux) (Color: Double-Sided Clear)
- 11 - Brushed Stainless Steel
- 12 - Maharam: Upholstry (Pattern: Alley-Force Field) (Color: Furnace)

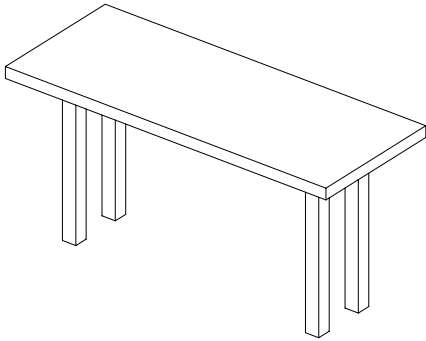

Custom Rectangular Table in finish 9
60"x24"x30" - Quantity 4

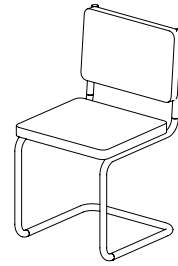

Breuer Chair in finish 6 and 11
L - 19"
W - 17"
H - 32"
Quantity: 8

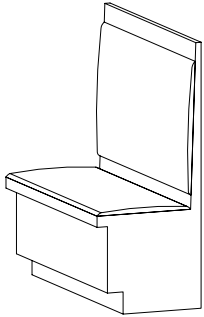

Custom Booth - L-Shaped in finish 12 and 9
Exterior Measurements
L - 84"
W - 61"
Depth - 21"
H - 48"
Quantity: 1

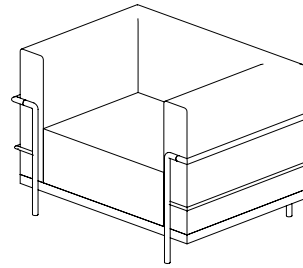

Corbusier Chair in finish 11 and 12
Quantity: 3 and in finish 11 and 6
Quantity: 1
L - 27.6"
W - 30"
H - 17"

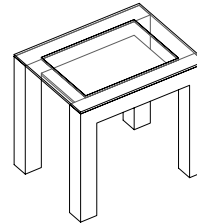

Custom Coffee Table in finish 9 and 10
L - 24"
W - 24"
H - 24"
Quantity: 3

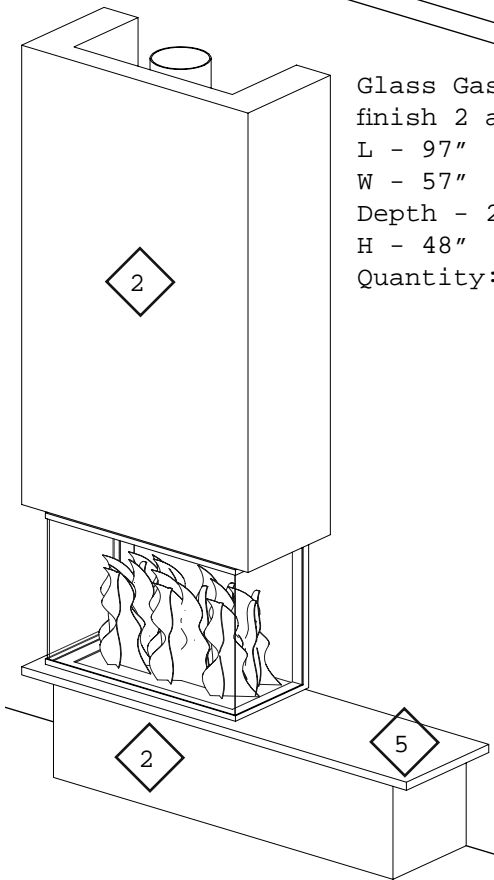

Glass Gas Fireplace in finish 2 and 5
L - 97"
W - 57"
Depth - 21"
H - 48"
Quantity: 1

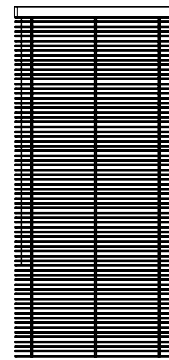

Wood Blinds in finish 8
W - 36"
H - 72"

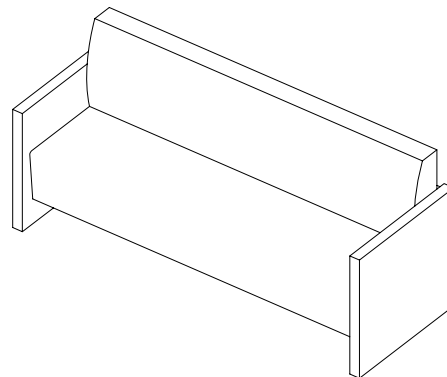

Custom Sofa in finish 12
L - 26"
W - 72"
H - 17"
Quantity: 1

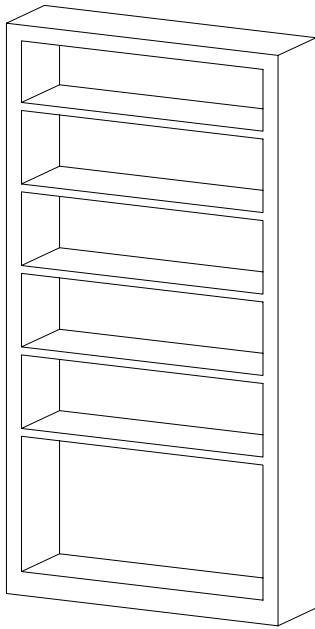

Shelving
in finish 9
L - 36"
W - 10"
H - 72"
Quantity: 2

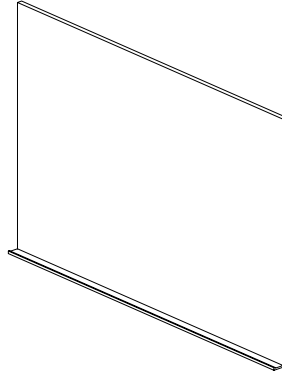

Dry Erase Board
W - 72"
H - 48"
Quantity: 1

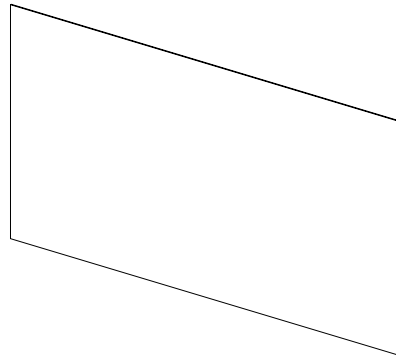

Tack Board
W - 96"
H - 48"
Quantity: 1

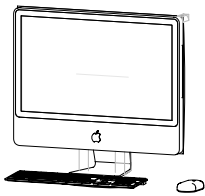

iMac Intel
Computer
Quantity: 2



Halls



Reading Area

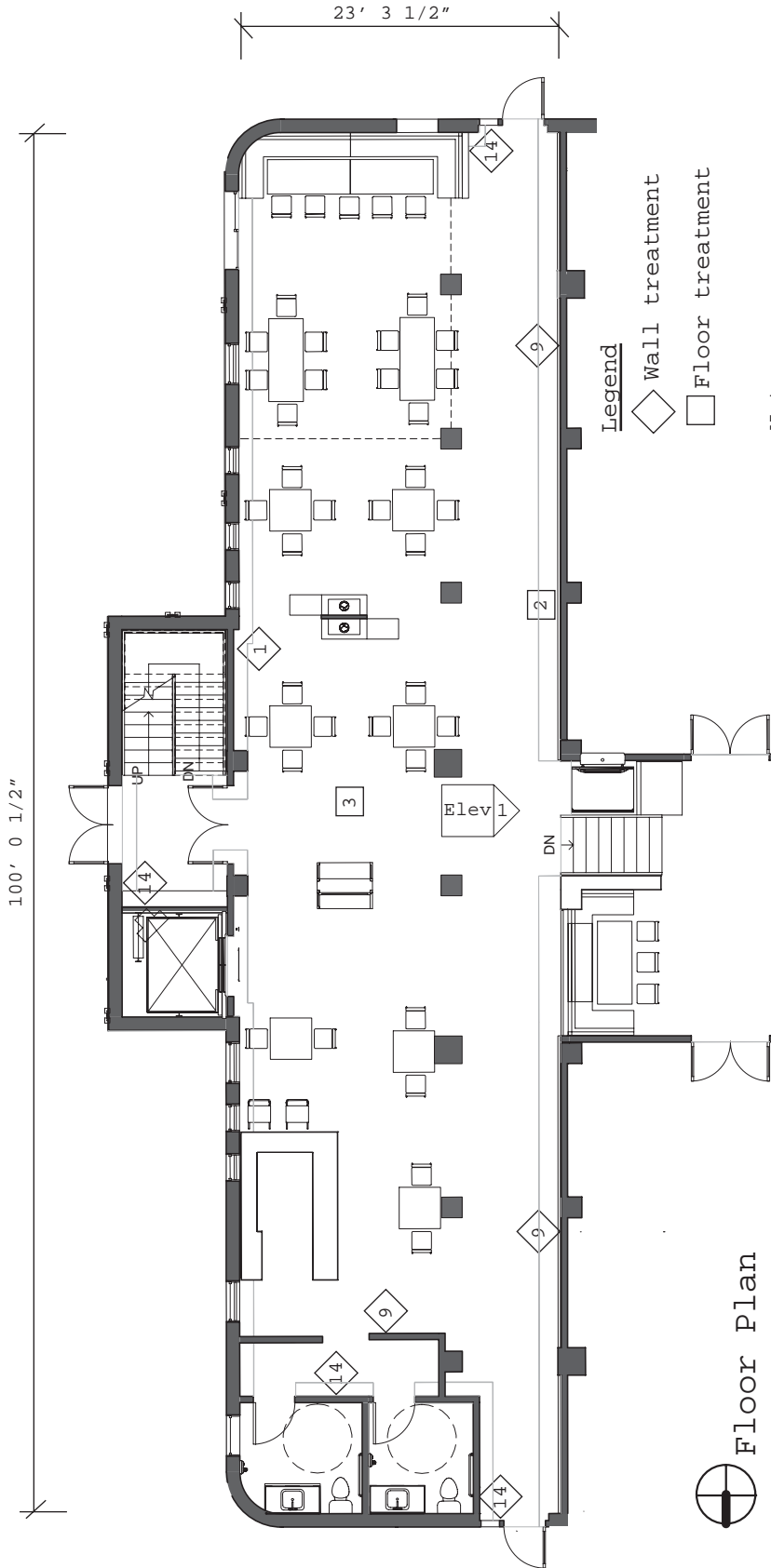

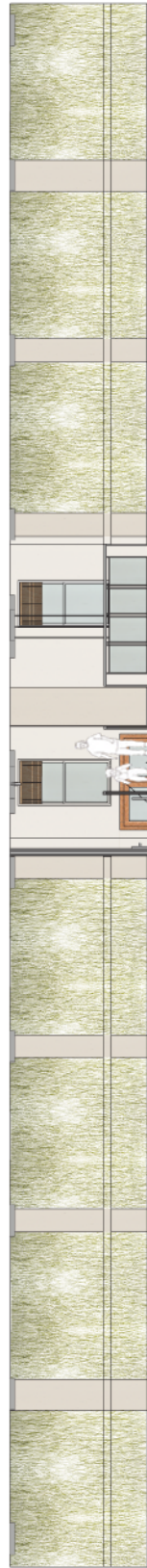

Ground floor
5' - 0"

Elevation 1

7.7.2 ■ Furnishing and Finishes



- 1 - Benjamin Moore Paint (Color: Ferret Brown)
- 2 - Forbo: Marmoleum Flooring (Pattern: Dual) (Color: Brick)
- 3 - Bruce: Hardwood Floors (Type: Solid Oak Hardwood) (Finish: BCC1100 Natural)
- 4 - DuPont: Zodiac Quartz Surfaces (Color: Celestial Blue)
- 5 - AGC Flat Glass North America: Acid-Etched Glass (Pattern: Matelux) (Color: Double-Sided Clear)
- 6 - Dow: Wood Stalk Bioproducts Strawboard (Finish: Natural)
- 7 - Red Brick
- 8 - DuPont: Zodiac Quartz Surfaces (Color: Space Black)
- 9 - 3Form Pressed Glass (Seaweed)
- 10 - Brushed Stainless Steel
- 11 - Maharam: Upholstry (Pattern: Alley-Force Field) (Color: Tide)
- 12 - BEHR Paint (Color: Polar Bear)
- 13 - White Birch (Finish: Natural)
- 14 - Benjamin Moore Paint (Color: Clay Beige)

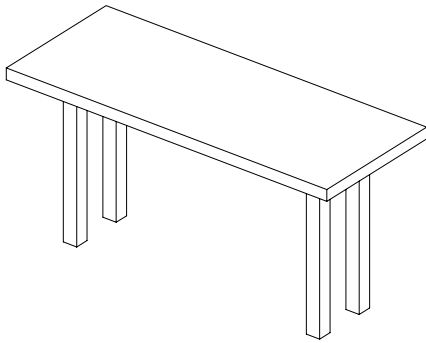

Custom Rectangular
Table in finish 6
36"x36"x30" - Quantity 7
72"x30"x30" - Quantity 4

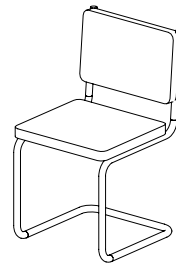

Breuer Chair
in finish 10 and 11
L - 19"
W - 17"
H - 32"
Quantity: 39

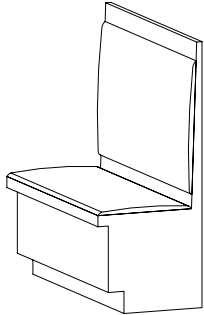

Custom Booth - L-Shaped
in finish 6 and 10
Exterior Measurements
L - 97"
W - 57"
Depth - 21"
H - 48"
Quantity: 2

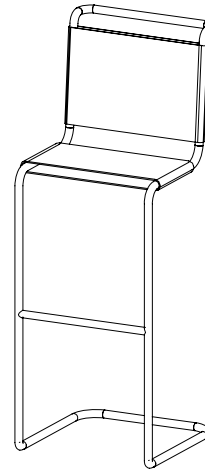

Bar Stool
in finish 10 and 11
L - 26"
W - 19"
H - 53"
Quantity: 2

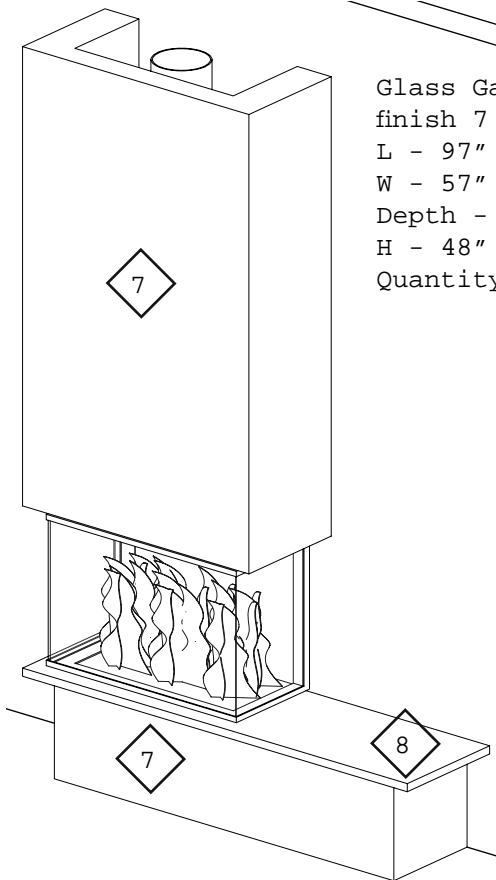

Glass Gas Fireplace in
finish 7 and 8
L - 97"
W - 57"
Depth - 21"
H - 48"
Quantity: 2

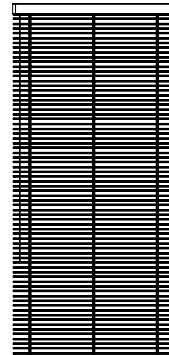

Wood Blinds in
finish 13
W - 36"
H - 72"
and
W - 24"
H - 72"

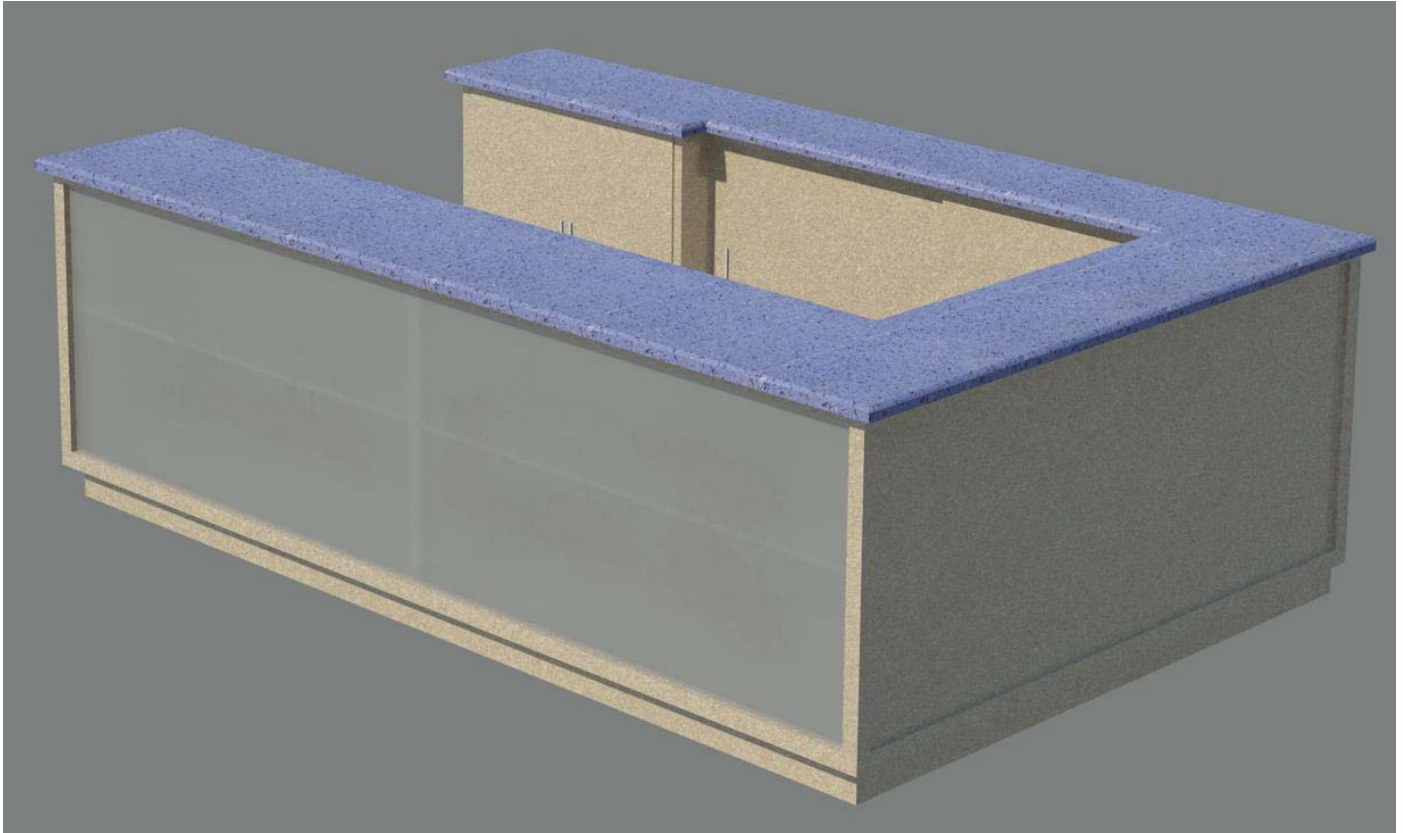

Coffee/Snack Bar

Note:

All structure
made of finish 6

All glass panels
made of finish 5

All hardware made
of finish 7

Counter top made of
finish 4

Small Counter Fridge

L - 20"
W - 30"
H - 36"

Quantity: 1

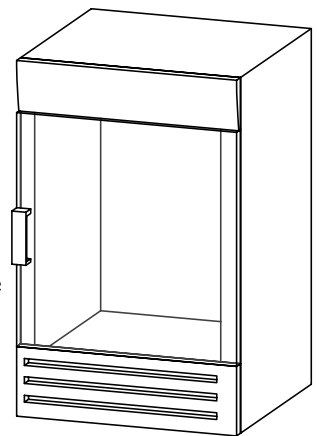

Commercial Coffee
Maker

Quantity: 1

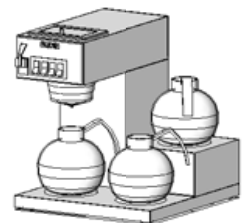

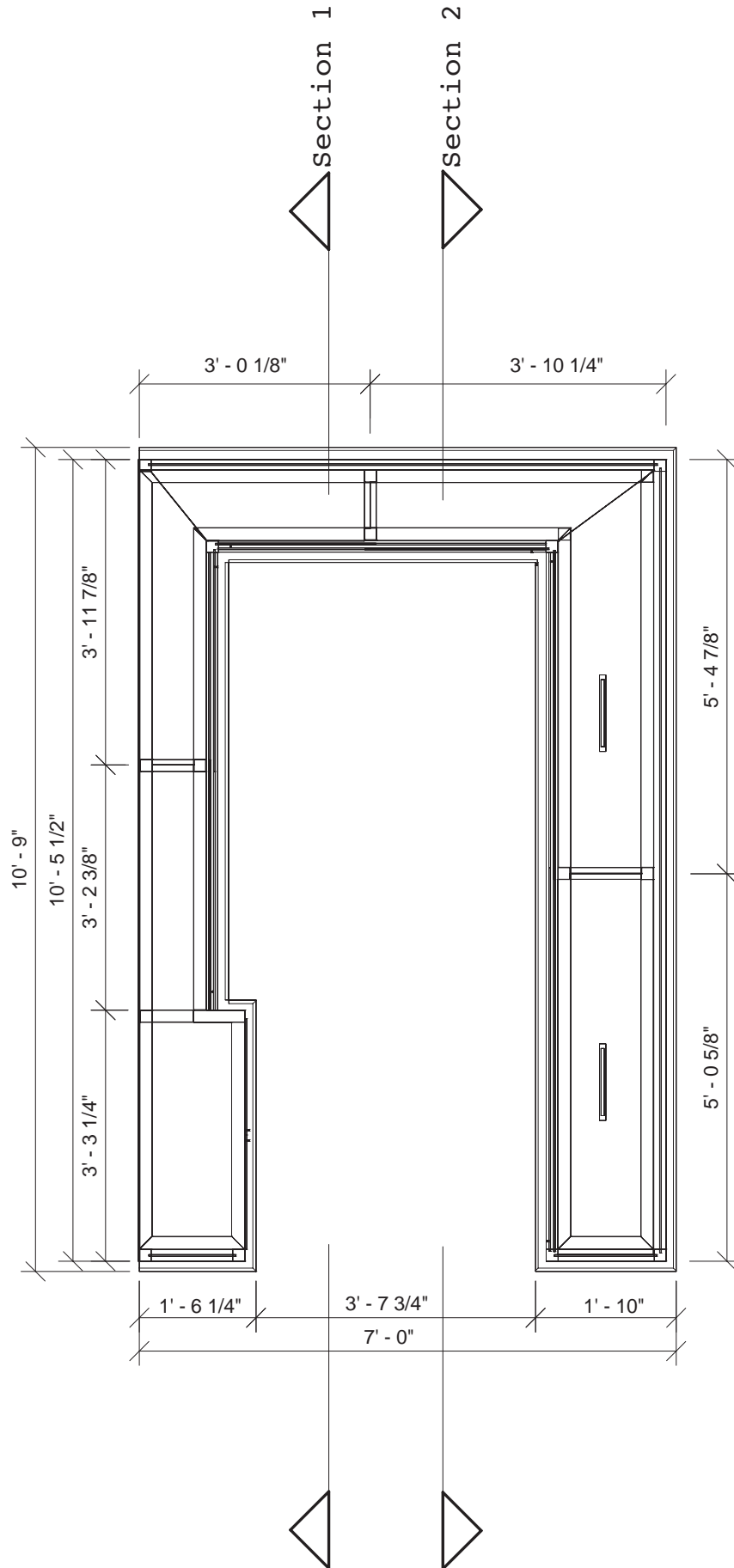

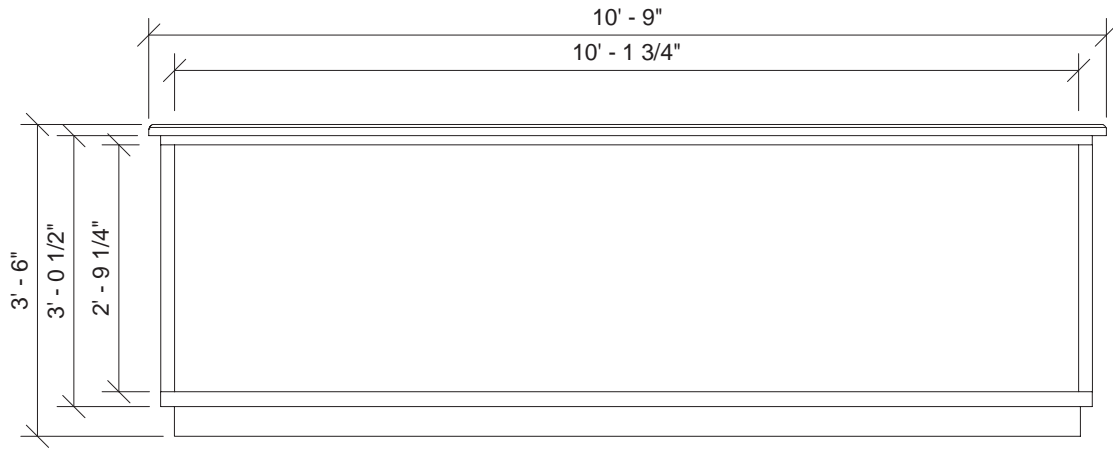

Front Elevation

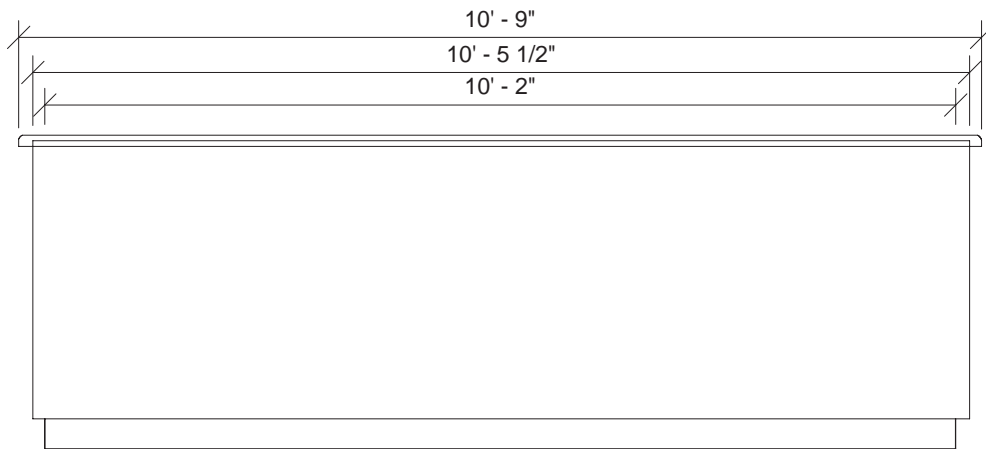

Back Elevation

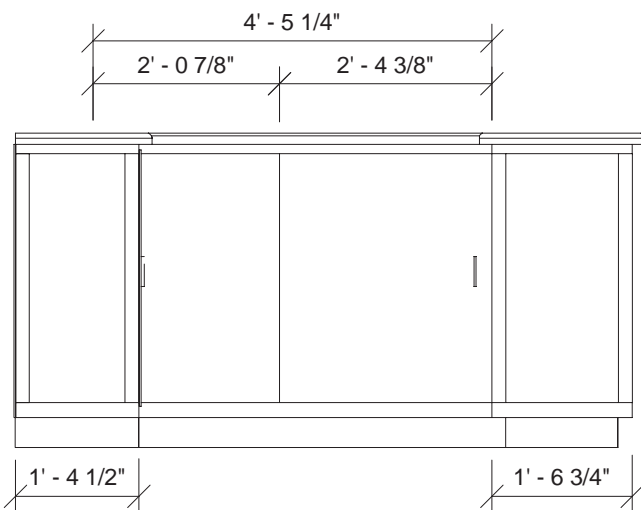

Left Elevation

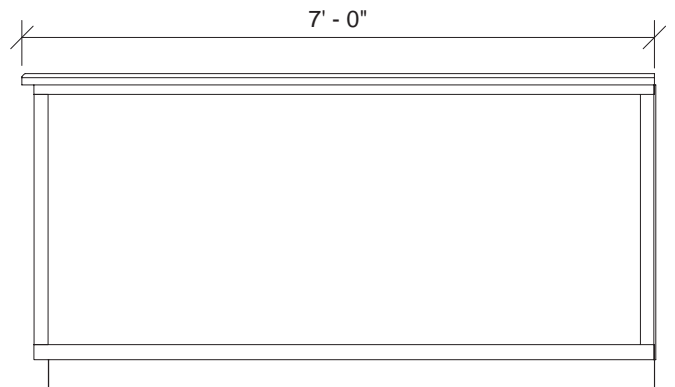

Right Elevation

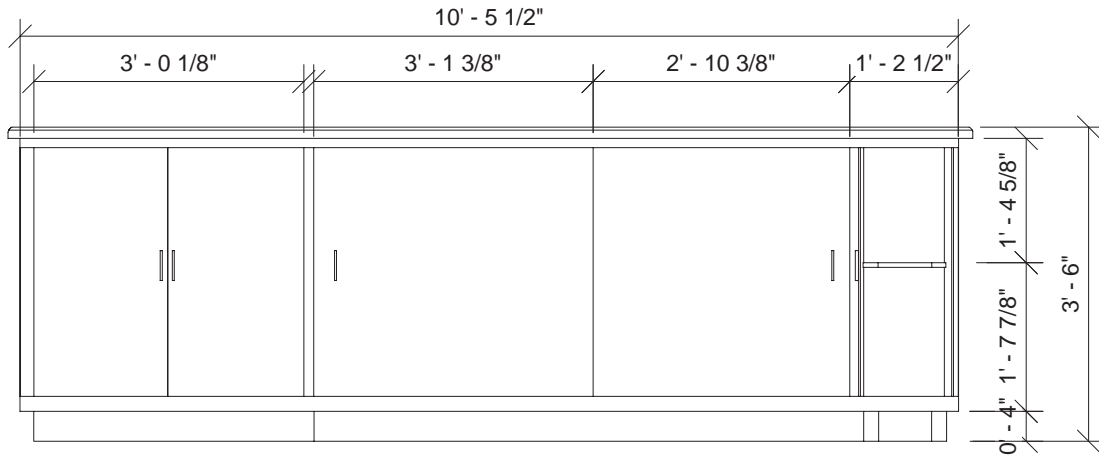

Section 1

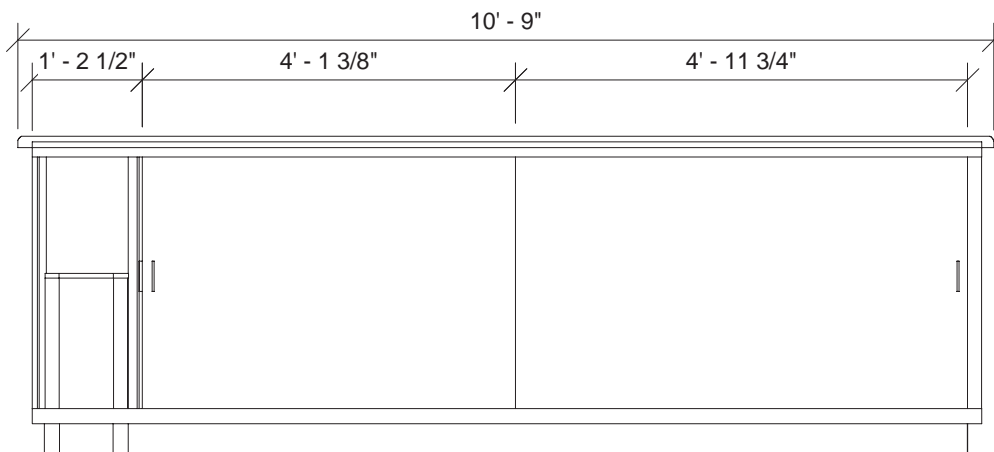

Section 2

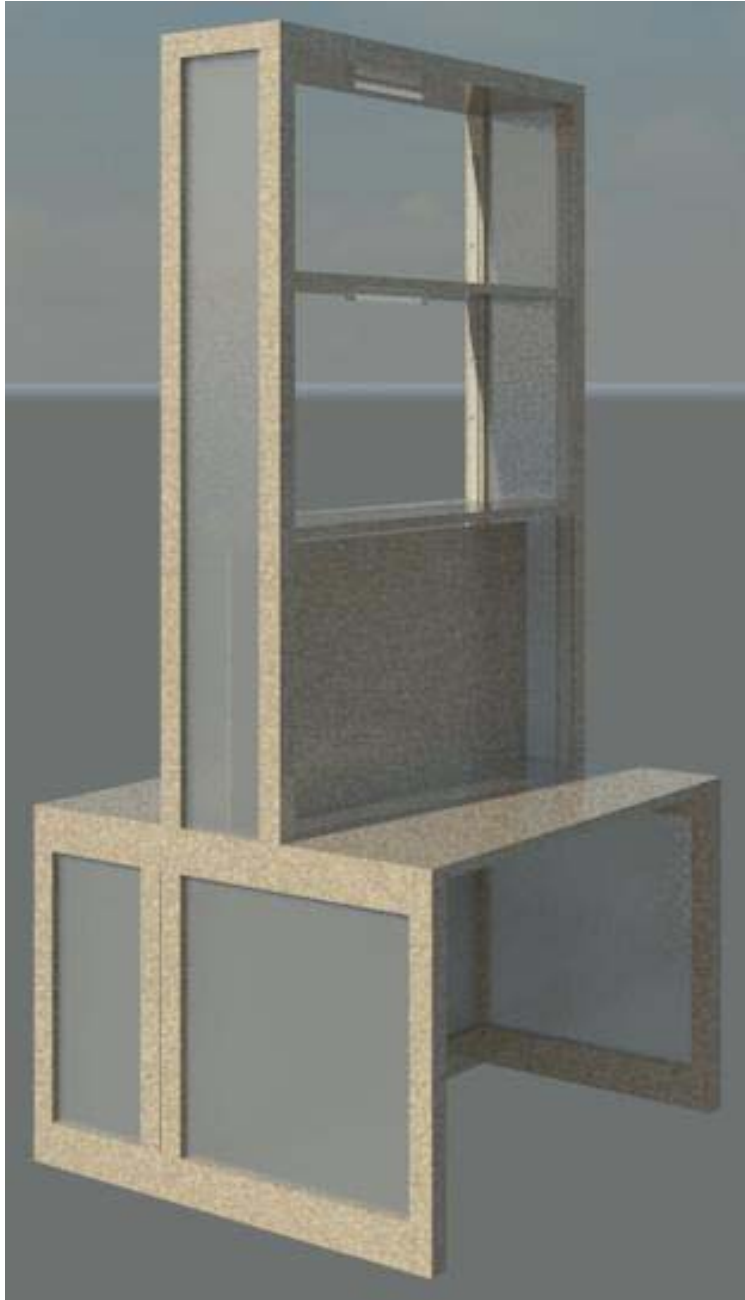

Communication Centre

Note:

All structure
made of finish 6

All glass panels
made of finish 5

All hardware made
of finish 7

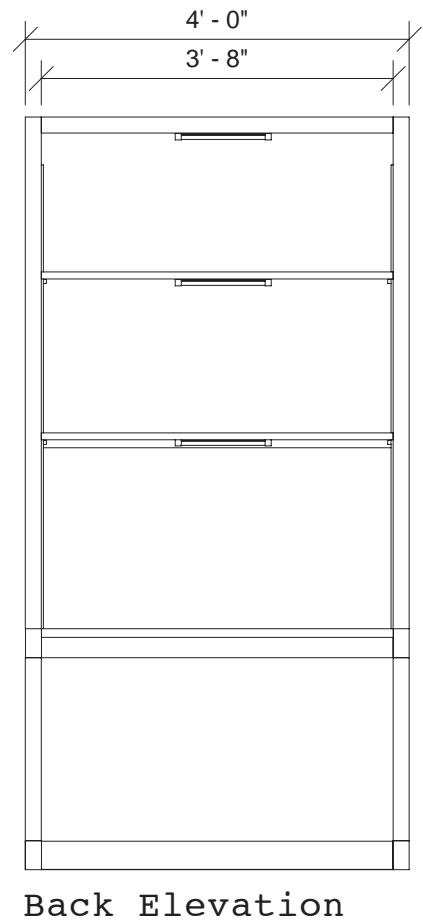
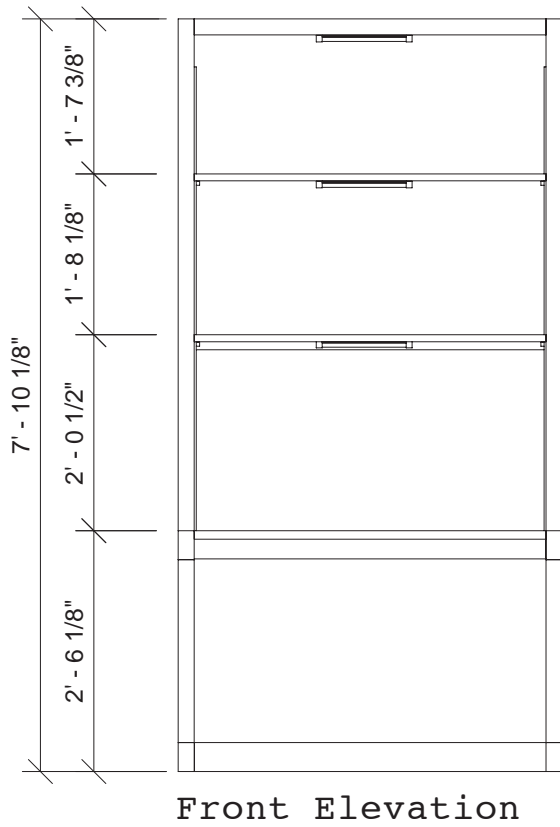
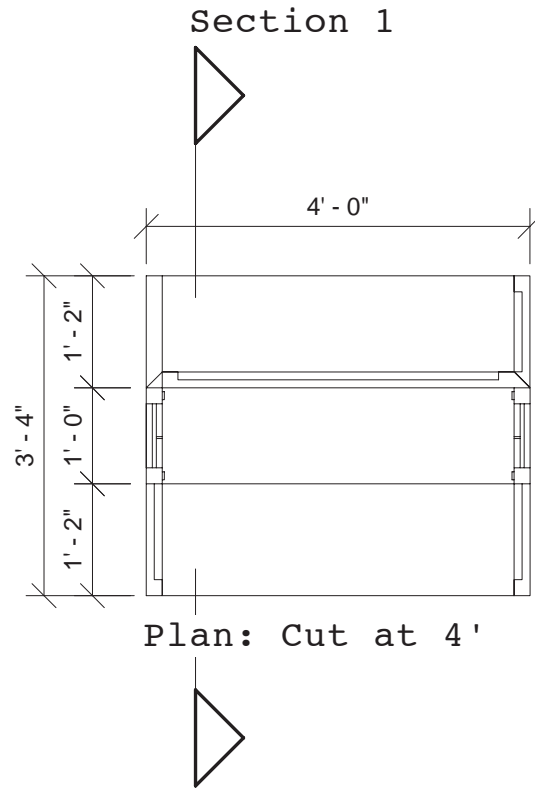

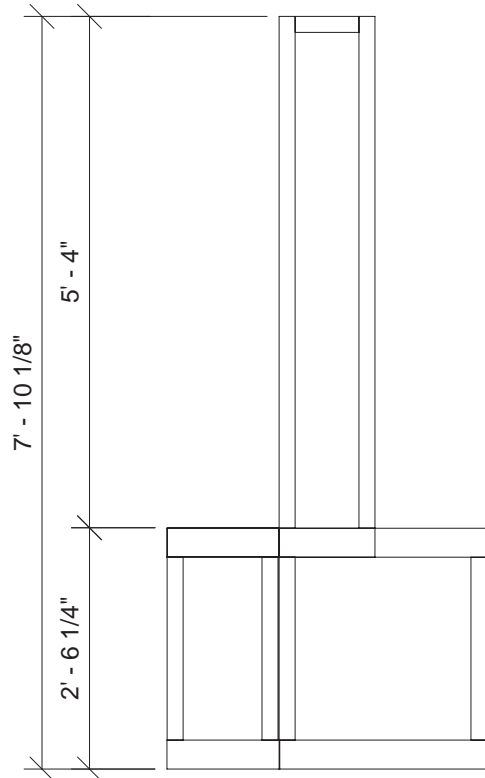

Left Elevation

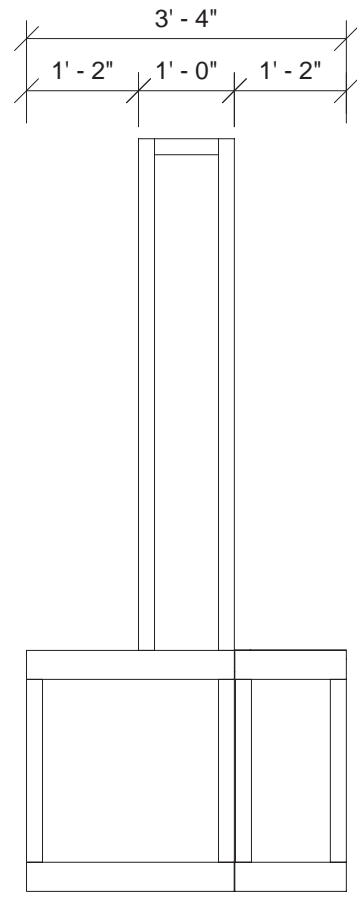

Right Elevation

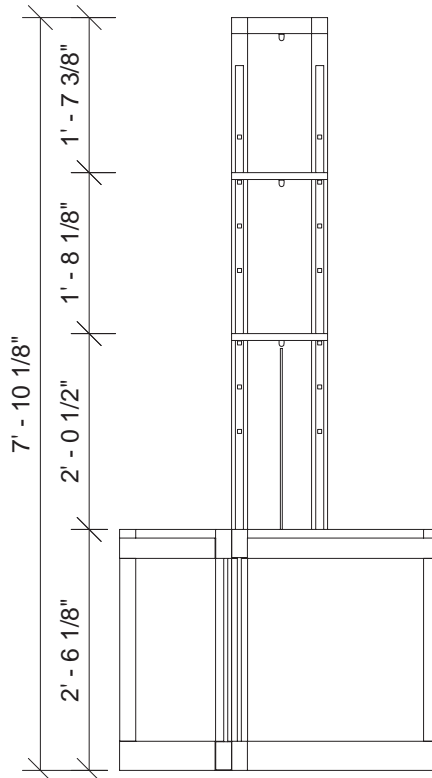

Section 1

7.7.3 ■ Perspectives



Communal Dining

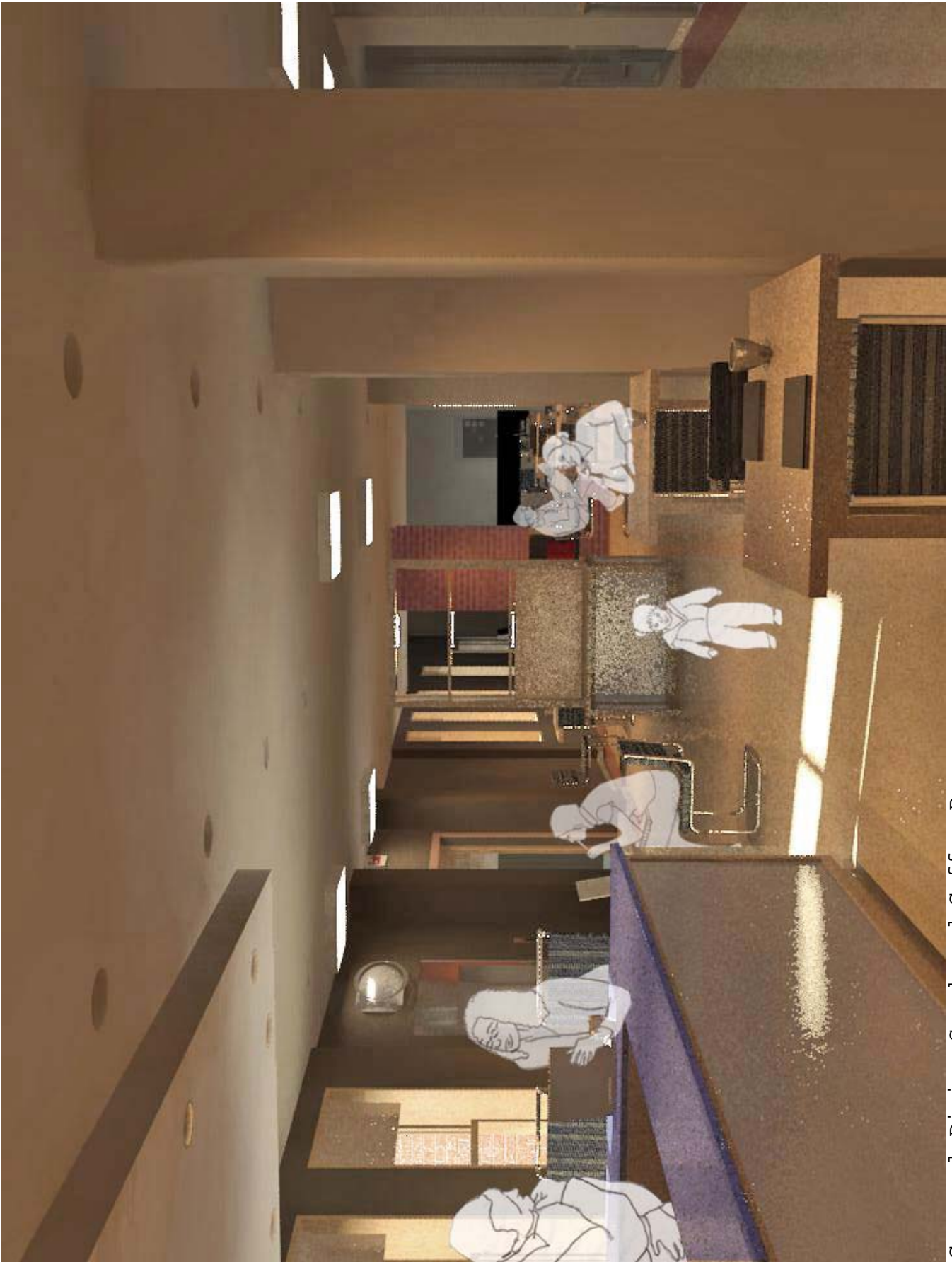

Communal Dining Snack and Coffee Bar

7.8.2 ■ Furnishing and Finishes

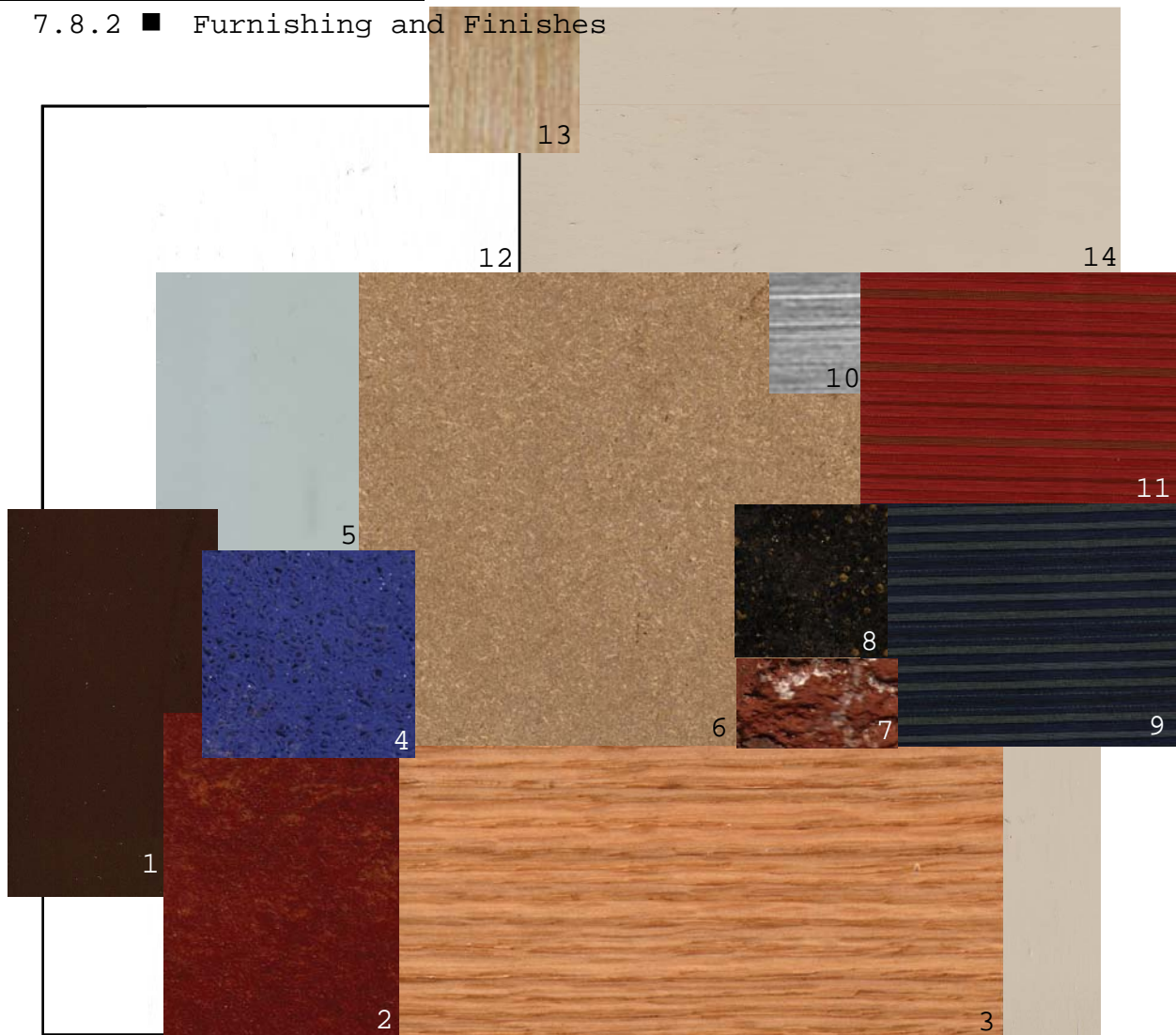

- 1 - Benjamin Moore Paint (Color: Ferret Brown)
- 2 - Forbo: Marmoleum Flooring (Pattern: Dual) (Color: Brick)
- 3 - Bruce: Hardwood Floors (Type: Solid Oak Hardwood) (Finish: BCC1100 Natural)
- 4 - DuPont: Zodiaq Quartz Surfaces (Color: Celestial Blue)
- 5 - AGC Flat Glass North America: Acid-Etched Glass (Pattern: Matelux) (Color: Double-Sided Clear)
- 6 - Dow: Wood Stalk Bioproducts Strawboard (Finish: Natural)
- 7 - Red Brick
- 8 - DuPont: Zodiaq Quartz Surfaces (Color: Space Black)
- 9 - Maharam: Upholstry (Pattern: Alley-Force Field) (Color: Tide)
- 10 - Brushed Stainless Steel
- 11 - Maharam: Upholstry (Pattern: Alley-Force Field) (Color: Furnace)
- 12 - BEHR Paint (Color: Polar Bear)
- 13 - White Birch (Finish: Natural)
- 14 - Benjamin Moore Paint (Color: Clay Beige)

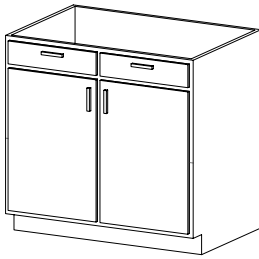

Base Cabinet - Double Door and 2 Drawer in finish 6
Hardware in finish 10
36" Height
30" - Quantity 1
36" - Quantity 2
42" - Quantity 1
45" - Quantity 1
30" Height
30" - Quantity 1
48" - Quantity 2

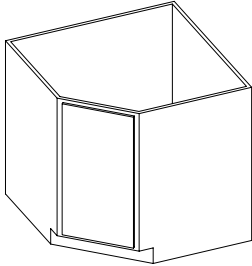

Base Cabinet - Corner Unit Angled in finish 6
Hardware in finish 10
36" Height
Quantity: 1



Base Cabinet - Single Door and Drawer in finish 6
Hardware in finish 10
36" Height
18" - Quantity 1
12" - Quantity 1
30" Height
18" - Quantity 1

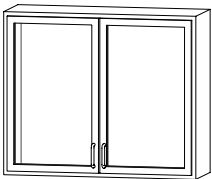

Wall Mounted Upper Cabinet - Double Door with Glass in finish 6 and 5
Hardware in finish 10
30" - Quantity 3
42" - Quantity 1

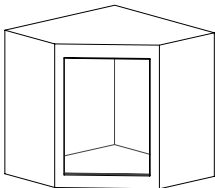

Wall Mounted Upper Cabinet - Corner Unit with Glass in finish 6 and 5
Hardware in finish 10
Quantity: 1



Wessan Drop In Single Bowl Stainless Steel Sink
L - 20"
W - 20"
H - 7"
Quantity: 1

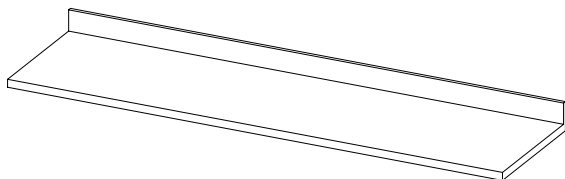

24" Depth Counter Top in finish 4



KitchenAid Architect 20.9 cu. ft. Built-In Refrigerator in finish 10
L - 23.5"
W - 35.5"
H - 83.3"
Quantity: 1



Kenmore Elite 40" Dual Fuel Range in finish 10
L - 27.4"
W - 40.1"
H - 48.1"
Quantity: 1



Bosch "Ascenta" Built-In Dishwasher finish 10
L - 22.5"
W - 23.5"
H - 33.9"
Quantity: 1



Wessan Double-Bowl Stainless Steel Sink
L - 22"
W - 37.25"
H - 7.125"
Quantity: 1



Blanco Single Lever, Pull-out Kitchen Faucet, in finish 10
Quantity: 2

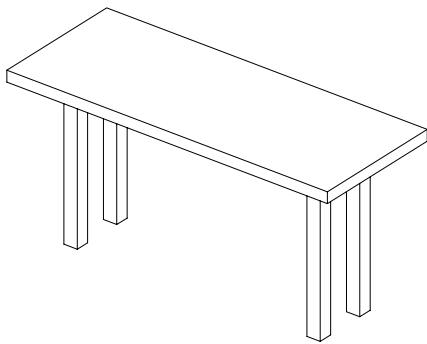

Custom Rectangular
Table in finish 6
36"x36"x30" - Quantity 4
84"x30"x30" - Quantity 2

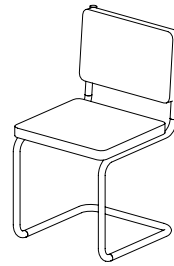

Breuer Chair
in finish 10 and 11
Quantity: 2
and
in finish 10 and 9
Quantity: 32
L - 19"
W - 17"
H - 32"

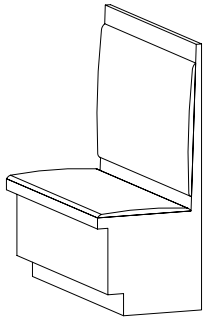

Custom Booth - L-Shaped
in finish 6 and 11
Exterior Measurements
L - 42"
W - 46"
Depth - 21"
H - 48"
Quantity: 1

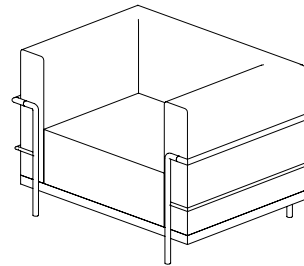

Corbusier Chair
in finish 10 and 11
L - 27.6"
W - 30"
H - 17"
Quantity: 6

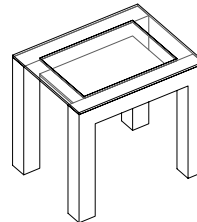

Custom Coffee Table
in finish 6 and 5
L - 24"
W - 24"
H - 24"
Quantity: 3

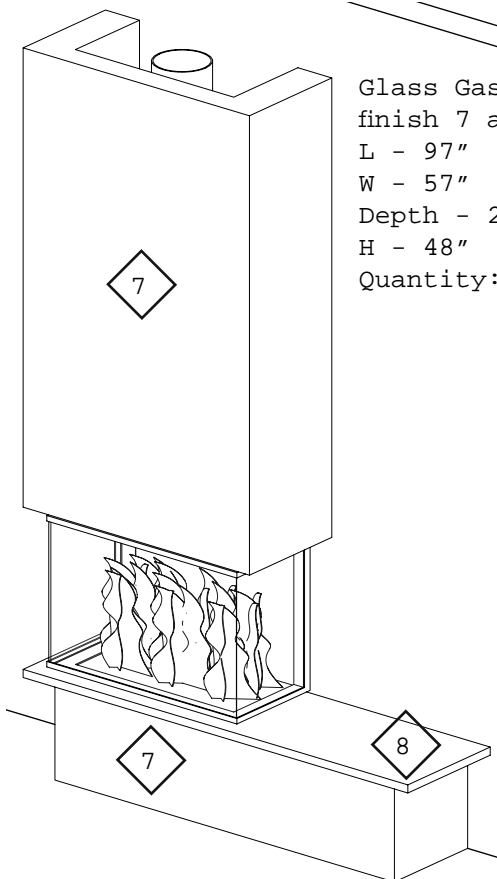

Glass Gas Fireplace in
finish 7 and 8
L - 97"
W - 57"
Depth - 21"
H - 48"
Quantity: 2

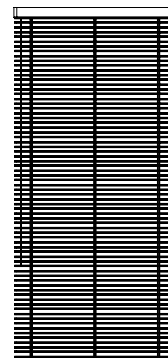

Wood Blinds in
finish 13
W - 36"
H - 72"
and
W - 24"
H - 72"

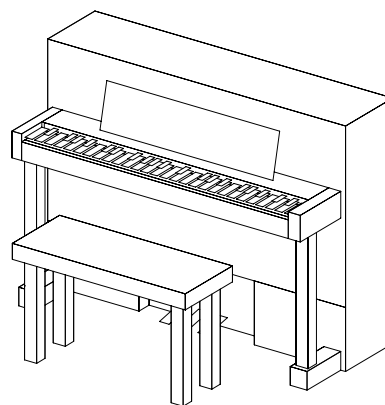

Console Piano in
Natural Oak finish
L - 26"
W - 60"
H - 42"
Quantity: 1

7.8.3 ■ Perspectives



Communal Kitchen

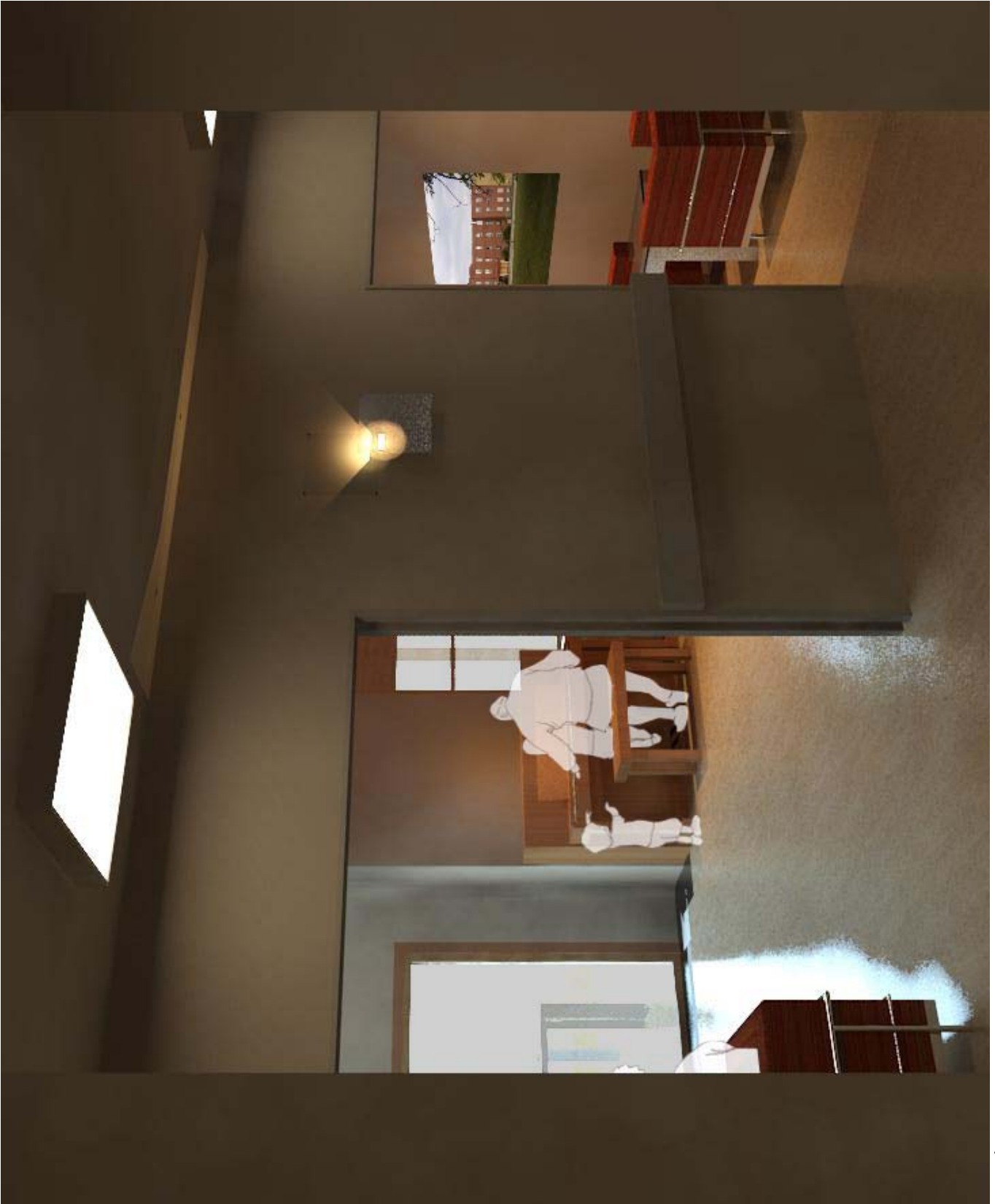

Music Area

With a rapidly evolving society, Canada is following the worldly focus towards urbanization, globalization and technological advancement. Issues brought forth in this proposal have demonstrated that these shifts have contributed to the progressively declining rural populations throughout the country. Along with providing much of the country's natural resources and amenities, small rural towns, specifically within the western prairie provinces where they historically hold a prominent presence, are part of our social, cultural, architectural and scenic heritage.

With the concentrated focus on rural, cultural and historical continuity in Canada, the rural prairie cohousing proposal initiates a shift in current living issues brought by an increasingly privatized and segregated society. By turning towards a home environment that integrates all individuals regardless of age, race, gender or ability, and that provides spaces for everyday face-to-face engagement and interaction, promotes all users of the project to establish strong social networks and meaningful teaching and learning experiences to one another through these relations. This in turn provides a sense of value, competence, support, creativity, and independence amongst the targeted user groups, both young, mid and old since "at the heart of any intergenerational connection is the belief that each of us, at every age has value" (Larson & Meyer, 2006, p.1). The promotion of cultural continuity and cross-age connections also allows for cross-generational comfort levels to rise and possibly regress some sense of age segregation and its discussed implications on various social relations.

This project is only one possible suggestion for the various issues discussed, with an underlying focus on bringing an awareness to the need for appropriate alternative housing models in such rural

areas. These models should cater to their specific changing demographics while also addressing social issues found amongst these individuals, like segregation, social networking and active communal participation, development and maintenance.

By bringing an interior design initiative to upgrading the housing situation found within the Canadian rural prairies, like the selected site of Melville, Saskatchewan, is one attempt to shift away from the dominance of the urbanization movement and draw attention to maintaining life in the rural prairies. Through a focus on establishing a housing solution that revolves around the incorporation of connection, community, integration, identity and preservation, the design project establishes one suitable housing alternative to the changing demographic within the Canadian rural prairies in hopes of initiating a concentration of efforts in sustaining these communities.

- Abbott, Pauline S., Carman, Nancy, Carman, Jack, & Scarfo, Bob. (2009). *Re-Creating Neighborhoods for Successful Aging*. Maryland: Health Professions Press Inc.
- Ahrentzen, Sherry. (1989). Overview of Housing for Single-Parent Households. In Franck, Karen A. & Ahrentzen, Sherry (eds.), *New Households New Housing* (143-160). New York: Van Nostrand Reinhold.
- Berry, Wendell. (1972). "The Regional Motive." In Canizaro, Vincent A. (ed.), *Architectural Regionalism: Collected Writings on Place, Identity, Modernity, and Tradition* (37-40). New York: Princeton Architectural Press.
- Brooker, Graeme, & Stone, Sally. (2004). *Re-Readings: Interior Architecture and the Design Principles of Remodelling Existing Buildings*. London: RIBA Enterprises.
- Canizaro, Vincent A. (ed.). (2007). *Architectural Regionalism: Collected Writings on Place, Identity, Modernity, and Tradition*. New York: Princeton Architectural Press.
- Colquhoun, Alan. (2002). *Modern Architecture*. Oxford: Oxford University Press.
- David, Bruce et al. (2003). *Housing Needs of Low-Income People Living in Rural Areas*. Retrieved June 3, 2008, from ebrary database.
- De Peuter, Jennifer. (2005). *Rural Saskatchewan Profile: A Ten Year Census Analysis (1991-2001)*. Retrieved May 29, 2008 from, ebrary database.
- Ebner, Peter. (2007). Integrated Living. In Schittich, Christian (ed.), *In Detail: Housing for People of All Ages* (10-23). Germany: Birkhauser.
- Eggener, Keith L. (2002). "Placing Resistance: A Critique of Critical Regionalism." In Canizaro, Vincent A. (ed.), *Architectural Regionalism: Collected Writings on Place, Identity, Modernity, and Tradition* (395-407). New York: Princeton Architectural Press.
- Environment Canada. (2000). *Canadian Climate Normals 1971-2000: Yorkton Saskatchewan*. Retrieved from: http://www.climate.weatheroffice.ec.gc.ca/advanceSearch/searchHistoricDataStations_e.html.
- Frampton, Kenneth. (1987). Ten Points on an Architecture of Regionalism: A Provisional Polemic. In Canizaro, Vincent A. (ed.), *Architectural Regionalism: Collected Writings on Place, Identity, Modernity, and Tradition* (375-385). New York: Princeton Architectural Press.
- Franck, Karen A. (1989). "Overview of Collective and Shared Housing." In Franck, Karen A. & Ahrentzen, Sherry (eds.), *New Households New Housing* (3-19). New York: Van Nostrand Reinhold.
- Franck, Karen A., & Ahrentzen, Sherry (eds.). (1989). *New Households New Housing*. New York: Van Nostrand Reinhold.

- Fromm, Dorit. (1991). *Collaborative communities : cohousing, central living, and other new forms of housing with shared facilities*. New York: Van Nostrand Reinhold.
- Gibbins, Roger. (2003). The Rural Face of the New West. In Blake, Raymond and Andrew Nurse (eds.), *The Trajectories of Rural Life: New Perspectives on Rural Canada* (137-144). Regina: Saskatchewan Institute of Public Policy.
- Gifford, Robert. (2002). *Environmental Psychology: Principles and Practice*. Canada: Optimal Books.
- Hagestad, Gunhild O., & Uhlenberg, Peter. (2006). Should We Be Concerned About Age Segregation? Some Theoretical and Empirical Explorations. *Research on Aging*, 28 (6), 638-653.
- Heywood, Frances, Oldman, Christine, & Means, Robin. (2002). *Housing and Home in Later Life*. Buckingham: Open University Press.
- Jaffe, Dale J. (1989). *Caring Strangers: The Sociology of Intergenerational Homesharing*. London: Jai Press Ltd.
- Jean, Bruno. (2003). Rethinking the Relationship Between City and Country: Or Why Urbanites Must Support Rural Revitalization. In Blake, Raymond and Andrew Nurse (eds.), *The Trajectories of Rural Life: New Perspectives on Rural Canada* (155-160). Regina: Saskatchewan Institute of Public Policy.
- Larson, Jean M., & Hockenberry Meyer, Mary. (2006). *Generations Gardening Together: Sourcebook for Intergenerational Therapeutic Horticulture*. New York: Food Products Press.
- Lefaiivre, Liane, & Tzonis, Alexander. (2003). *Critical Regionalism: Architecture and Identity in a Globalized World*. New York: Prestel.
- Low, Colin (Producer and Director). (1964). *The Hutterites* [Documentary]. Canada: National Film Board of Canada.
- MacKeith, Peter (ed.). (2005). *Encounters: Architectural Essays*. Finland: Rakennustie to Oy.
- McCamant, Kathryn & Durrett, Charles. (1988). *Cohousing: A Contemporary Approach to Housing Ourselves*. California: Ten Speed Press.
- McPherson, B., & Wister, A. (2008). *Aging as a Social Process: Canadian Perspectives*. Ontario: Oxford University Press.
- Melville History Book Committee. (1983). *The Ties That Bind: Melville '83*. Altona: Friesen Printers.
- Moore, Steven A. (2005). "Technology, Place, and Nonmodern Regionalism." In Canizaro, Vincent A. (ed.), *Architectural Regionalism: Collected Writings on Place, Identity, Modernity, and Tradition* (433-442). New York: Princeton Architectural Press.
- Newman, Sally, Ward, Christopher R., Smith, Thomas B., Wilson, Janet O., & McCrea, James M. (1997). *Intergenerational Programs: Past, Present, and Future*. United States: Taylor & Francis.

- Pallasmaa, Juhani. (1988). Tradition and Modernity: The Feasibility of Regional Architecture in Post-Modern Society. In Canizaro, Vincent A. (ed.), *Architectural Regionalism: Collected Writings on Place, Identity, Modernity, and Tradition* (129-139). New York: Princeton Architectural Press.
- Peter, Karl Andreas. (1987). *The Dynamics of Hutterite Society: an analytical approach*. Alberta: The University of Alberta Press.
- Planning Research Centre, University of Manitoba. (1952). *Farm Kitchens and Utility Rooms*. Manitoba: University of Manitoba Planning Research Centre.
- Rees, Ronald, & Tracie, Carl J. (1978). The Prairie House. *Landscape*, 22 (3), 3-8.
- Rothwell, Neil. (2008, December 5). Study: Seniors in Rural Canada 1986 to 2006. *The Daily*. Retrieved from <http://www.statcan.gc.ca/daily-quotid-en/081205/dq081205c-eng.htm>.
- Sawatzky, Roland. (2005). *The Control of Social Space in Mennonite Housebarns of Manitoba, 1874-1940*. British Columbia: Simon Fraser University.
- Schittich, Christian. (2007). *In Detail: Housing for People of All Ages*. Germany: Birkhauser.
- Scotthanson, Chris, & Scotthanson, Kelly. (2005). *The Cohousing Handbook: Building a Place for Community*. Canada: New Society Publishers.
- Speck, Lawrence W. (1987). "Regionalism and Invention." In Canizaro, Vincent A. (ed.), *Architectural Regionalism: Collected Writings on Place, Identity, Modernity, and Tradition* (71-79). New York: Princeton Architectural Press.
- Stahl, Lisa Marie. (2003). *My Hutterite Life*. Montana: Farcountry Press.
- Statistics Canada. (2006). *Community Profiles from the 2006 Census*. Retrieved from <http://www12.statcan.ca/census-recensement/2006/dp-pd/prof/92-591/details/Page.cfm?Lang=E&Geol=CSD&Code1=4708021&Geo2= PR&Code2=47&Data=Count&SearchText=Enterpris%20No.%20142&SearchType=Begins&SearchPR=01&Bl=All&Custom=>.
- Ward, Peter. (1999). *A History of Domestic Space: Privacy and the Canadian Home*. Canada: UBC Press.
- Wentling, James W. (1995). *Housing By Lifestyle*. New York: McGraw-Hill Inc.

Figures 1 & 2 - Statistics Canada. (2006). *Population Urban and Rural, By Province and Territory*. Retrieved from <http://www40.statcan.gc.ca/l01/cst01/demo62a-eng.htm>.

Figure 3 - Ward, Peter. (1999). *A History of Domestic Space: Privacy and the Canadian Home*. Canada: UBC Press.

Figures 5-8 - The former St. Peter's Hospital in Melville, Saskatchewan. © Vanessa Ilg, 2008.

Figure 9 - Government of Manitoba. (2009). *Manitoba Municipal Heritage Site No. 226*. Retrieved from <http://www.gov.mb.ca/chc/hrb/mun/m226.html>.

Figure 11 - Retrieved from http://farm2.static.flickr.com/1209/1433697068_679b65e87b.jpg?v=0.

Figure 12 - Retrieved from http://farm4.static.flickr.com/3167/2624865912_de9238761f.jpg.

Figure 13 - Retrieved from <http://www.canada-maps.org/saskatchewan/images/wheat-saskatchewan.jpg>.

Figures 14, 43-46 - Melville, Saskatchewan and surrounding site. © Vanessa Ilg, 2009.

Figure 15 - Retrieved from <http://www.gov.mb.ca/agriculture/crops/fruit/images/bld01s01a.jpg>.

Figure 17 - Retrieved from http://image07.webshots.com/7/2/37/8/90823708WSXkfn_ph.jpg.

Figures 25-27 - McCamant, Kathryn, & Durrett, Charles. (1988). *Cohousing: A Contemporary Approach to Housing Ourselves*. California: Ten Speed Press.

Figures 28-32 - Schittich, Christian. (2007). *In Detail: Housing for People of All Ages*. Germany: Birkhauser.

Figures 33 & 34 - Jetsonen, Jari & Lahti, Markku. (2005). *Alvar Aalto Houses*. Helsinki: Rakennustieto Oy (Building Information Ltd.).

Figures 35 & 36 - Zabalbeascoa, Anatxu & Marcos, Javier Rodriguez (eds). (1998). *Sustainable Architectures: Renzo Piano*. California: Ginkgo Press Inc.

Figures 4 & 37 - Saskatchewan map. Original from CAA Manitoba/Saskatchewan Map.

Figure 39 - Melville town map. Original from Tourism Melville.

Figures 40-42, 47-49 - Original former St. Peter's hospital plans. Originals drawn by W. G. Vanegmond and Stan. E. Storey Architects, Regina, Saskatchewan.

Suites (1 Bedroom, 2 Bedroom, 3 Bedroom)

Required Square Footage: 350-1100	Number Required	Average Dimensions for Square Footage of Room (LxWxH)	Special Features
Furniture/Fixtures/Equipment Cooking: 60-100 sq ft			
Range	1	24"x27"x36"	
Dishwasher	1	25"x24"x35"	
Refrigerator	1	23"x28"x60"	
Microwave storage	1	18"x12"x12"	
Wash basin	2	16"x18"x6"	Pull-out nose Single lever
Work surface	/	20 linear feet	Various heights (34" to 36") Some pull-out
House ware/utensil storage	/	40 cubic feet	Built-in with adjustable shelving Overhead storage at 16" above counter top
Dry food storage	/	30 cubic feet	Built-in with adjustable shelving Overhead storage at 16" above counter top
Sensory Requirements			
Lighting		Illuminance Category E ¹ with range of general illuminance required between 500 to 750 lux providing adjustable ambient and task lighting for performance of visual tasks of medium contrast or small size	
Color		Nourishment: connected to wheat field scene Lightness: medium contrast Golden: overall warmth with cool accents	
Material Requirements		Stain resistant and durable	
Desired Character		A warm, bright space with an airy, open plan and linear forms	
Technology Requirements			
Heating/Cooling		Existing	
Ventilation		Existing with addition of fan over range	
Special (Electrical)		Outlets at 18" above floor	
¹ Illuminance Categories and Illuminance Values for Generic Types of Activities in Interiors from the Lighting Handbook of the Illuminating Engineering Society of North America			

Table 1 - Functional, Technological and Spatial Requirements
Suite Cooking Area

Suites (1 Bedroom, 2 Bedroom, 3 Bedroom)

Required Square Footage: 100-120		Average Dimensions for Square Footage of Room (LxWxH)
Furniture/Fixtures/Equipment	Number Required	
<i>Dining: 60-100 sq ft</i>		
Table for 4 or 6	1	48"x36"x30" to 72"x42"x30"
Seating	2 to 6	23"x18"x38"
Sensory Requirements		
Lighting		Illuminance Category C ¹ with range of general illuminance required between 100 to 200 lux providing adjustable ambient and task lighting where visual tasks are only occasionally performed
Color		Nourishment: connected to wheat field scene Lightness: medium contrast Golden: overall warmth with cool accents
Material Requirements		Easy to clean
Desired Character		A warm, bright space with an airy, open plan and linear forms
Technology Requirements		
Heating/Cooling		Existing
Ventilation		Existing
Special (Electrical)		Outlets at 18" above floor
¹ Illuminance Categories and Illuminance Values for Generic Types of Activities in Interiors from the Lighting Handbook of the Illuminating Engineering Society of North America		

Table 2 - Functional, Technological and Spatial Requirements Suite Dining Area

Suites (1 Bedroom, 2 Bedroom, 3 Bedroom)

Required Square Footage: 350-1100	Number Required	Average Dimensions for Square Footage of Room (LxWxH)	Special Features
Furniture/Fixtures/Equipment <i>Living: 60-130 sq ft</i>			
Lounge seating for three	1	78"x38"x18"	Moveable
Lounge seating for one	2 to 3	42"x38"x18"	Moveable
Low set table	1	48"x24"x16"	Moveable
Built-in display	/		
Hearth	1	30"x36"	Incorporation of bricks that match exterior
Balcony	1	120"x72"	Sliding doors with bottom mount flush with floor
Sensory Requirements			
Lighting		Illuminance Category B ¹ with range of general illuminance required between 50 to 100 lux providing an overall warm, adjustable ambient and task lighting for simple orientation	
Color		Embracing: cluster of poplar trees on winter landscape Juxtaposed: high contrast Encompassed: light, neutral background with dark, warm accents	
Material Requirements		Mix of soft surfaces set within a more solid surrounding	
Desired Character		A comfortable, inviting atmosphere with a mix of flowing and linear forms that speaks to the concept of protection and warmth from the harsh prairie winters	
Technology Requirements			
Heating/Cooling		Existing	
Ventilation		Existing	
Special (Electrical)		Outlets at 18" above floor	
¹ Illuminance Categories and Illuminance Values for Generic Types of Activities in Interiors from the Lighting Handbook of the Illuminating Engineering Society of North America			

Table 3 - Functional, Technological and Spatial Requirements Suite Living Area

Suites (1 Bedroom, 2 Bedroom, 3 Bedroom)

Required Square Footage: 350-1100	Number Required	Average Dimensions for Square Footage of Room (LxWxH)	Special Features
Furniture/Fixtures/Equipment <i>Sleeping: 60-150 sq ft</i>			
Bed	1	75"x54"x22" to 80"x60"x22"	Possible shared built-in storage with an adjacent bathroom
Built-in storage	/	18,000 cubic feet	
Sensory Requirements			
Lighting		Illuminance Category B ¹ with range of general illuminance required between 50 to 100 lux providing an overall warm, adjustable ambient and task lighting for simple orientation	
Color		Embracing: cluster of poplar trees on winter landscape Juxtaposed: high contrast Encompassed: light, neutral background with dark, warm accents	
Material Requirements		Soft and embracing	
Desired Character		A comfortable, inviting atmosphere with a mix of flowing and linear forms that speaks to the concept of protection and warmth from the harsh prairie winters	
Technology Requirements			
Heating/Cooling		Existing	
Ventilation		Existing	
Special (Electrical)		Outlets at 18" above floor	
¹ Illuminance Categories and Illuminance Values for Generic Types of Activities in Interiors from the Lighting Handbook of the Illuminating Engineering Society of North America			

Table 4 - Functional, Technological and Spatial Requirements Suite Sleeping Area

Suites (1 Bedroom, 2 Bedroom, 3 Bedroom)

Required Square Footage: 350-1100		Number Required	Average Dimensions for Square Footage of Room (LxWxH)	Special Features
Furniture/Fixtures/Equipment	Bathing: 80-120 sq ft			
Bath		1	58"x30"x14"	Room for grab bar installation if required
Shower		1	63"x31" 36"x36"	Roll-in or transfer shower with seat and space for possible grab bars Detachable shower head
Toilet		1	28"x20"x28"	Room around for grab bar installation if required
Wash station		1	36"x20"x30"	Single lever on wash basin Moveable storage and/or doors under sink
Built-in storage		/	2,000-3,000 cubic feet	Possible shared built-in storage with adjacent bedroom
Sensory Requirements				
Lighting				Illuminance Category D ¹ with range of general illuminance required between 200 to 500 lux providing ambient and task lighting for performance of visual tasks of high contrast or large size Rejuvenation: small bodies of water found around site
Color				Uniform: low to medium contrast Refresh: cool, medium and light tones
Material Requirements				Water resilient and durable
Desired Character				A bright, awakening, fresh character with linear forms
Technology Requirements				
Heating/Cooling				Existing
Ventilation				Addition of exhaust fan
Special (Electrical)				Outlets at 18" above floor
¹ Illuminance Categories and Illuminance Values for Generic Types of Activities in Interiors from the Lighting Handbook of the Illuminating Engineering Society of North America				

Table 5 - Functional, Technological and Spatial Requirements
Suite Bathing Area

Suites (1 Bedroom, 2 Bedroom, 3 Bedroom)

Required Square Footage: 350-1100			
Furniture/Fixtures/Equipment	Number Required	Average Dimensions for Square Footage of Room (LxWxH)	
<i>Guest Suite: 150 sq ft</i>			
Bed	1	75"x54"x22"	
Built-in storage	/	18,000 cubic feet	
Shower	1	36"x36"	
Toilet	1	28"x20"x28"	
Wash station	1	24"x20"x30"	
Sensory Requirements			
Lighting	Illuminance Category B ¹ with range of general illuminance required between 50 to 100 lux providing an overall warm, adjustable ambient and task lighting for simple orientation		
Color	To follow other suites		
Material Requirements	To follow other suites		
Desired Character	To follow other suites		
Technology Requirements			
Heating/Cooling	Existing		
Ventilation	Existing		
Special (Electrical)	Outlets at 18" above floor		
¹ Illuminance Categories and Illuminance Values for Generic Types of Activities in Interiors from the Lighting Handbook of the Illuminating Engineering Society of North America			

Table 6 - Functional, Technological and Spatial Requirements
Guest Suites

Communal Living

Required Square Footage: 50-150	Number Required	Average Dimensions for Square Footage of Room (LxWxH)
Furniture/Fixtures/Equipment		
<i>Sitting area</i>		
Lounge seating for three	1	78"x38"x18"
Lounge seating for one	2 to 3	42"x38"x18"
Linear surface	/	8 linear feet
Sensory Requirements		
Lighting		Illuminance Category B ¹ with range of general illuminance required between 50 to 100 lux providing an overall warm, adjustable ambient and task lighting for simple orientation
Color		Embracing: cluster of poplar trees on winter landscape Juxtaposed: high contrast Encompassed: light, neutral background with dark, warm accents
Material Requirements		Mix of soft surfaces set within a more solid surrounding
Desired Character		A comfortable, inviting atmosphere with linear forms that speaks to the concept of protection and warmth from the harsh prairie winters
Technology Requirements		
Heating/Cooling		Existing
Ventilation		Existing
Special (Electrical)		Outlets at 18" above floor
¹ Illuminance Categories and Illuminance Values for Generic Types of Activities in Interiors from the Lighting Handbook of the Illuminating Engineering Society of North America		

Table 7 - Functional, Technological and Spatial Requirements
Sitting Area

Communal Living

Required Square Footage: 200	Number Required	Average Dimensions for Square Footage of Room (LxWxH)
Furniture/Fixtures/Equipment <i>Indoor play area</i>		
Linear surface	/	20 linear feet
Sensory Requirements		
Lighting		Illuminance Category B ¹ with range of general illuminance required between 50 to 100 lux providing an overall warm, adjustable ambient and task lighting for simple orientation
Color		Embracing: saskatchewan lily image Juxtaposed: high contrast Encompassed: accented deep, warm earth tones surrounded by light, cool backdrop
Material Requirements		Easy to clean surfaces
Desired Character		A playful, inviting atmosphere with linear forms that carries a sense of embracement
Technology Requirements		
Heating/Cooling		Existing
Ventilation		Existing
Special (electrical)		Safety covers or higher placed outlets
¹ Illuminance Categories and Illuminance Values for Generic Types of Activities in Interiors from the Lighting Handbook of the Illuminating Engineering Society of North America		

Table 8 - Functional, Technological and Spatial Requirements
Indoor Play Area

Communal Living

Required Square Footage: 300			
Furniture/Fixtures/Equipment	Number Required	Average Dimensions for Square Footage of Room (LxWxH)	
Gaming area			
Foosball table	2	48"x24"x32"	
Pool table	1	96"x48"x30"	
Built-in display and storage	/	25 linear feet	
Television	1	42"x3.5"x26"	
Low set table	2	48"x24"x16"	
Lounge seating for 3	1	78"x38"x18"	
Lounge seating for 1	6	42"x38"x18"	
Sensory Requirements			
Lighting			Illuminance Category D ¹ with range of general illuminance required between 200 to 500 lux providing ambient and task lighting for performance of visual tasks of high contrast or large size
Color			Embracing: saskatchewan lily image Juxtaposed: high contrast Encompassed: accented deep, warm earth tones surrounded by light, cool backdrop
Material Requirements			Easy to clean surfaces
Desired Character			A playful, inviting atmosphere with linear forms that carries a sense of embracement
Technology Requirements			
Heating/Cooling			Existing
Ventilation			Existing
Special (electrical)			
¹ Illuminance Categories and Illuminance Values for Generic Types of Activities from the Lighting Handbook of the Illuminating Engineering Society of North America			

Table 9 - Functional, Technological and Spatial Requirements
Gaming Area

Communal Living

Required Square Footage: 550	Number Required	Average Dimensions for Square Footage of Room (LxWxH)
Furniture/Fixtures/Equipment		
<i>Exercise room</i>		
Treadmill	2	68"x26"x42"
Bike	1	82"x24"x30"
Weight station	1	45"x76"x85"
Elliptical trainer	1	56"x30"x66"
Boxing gym	1	84"x72"x96"
Bench seating	/	10 linear feet
Linear surface	/	15 linear feet
Sensory Requirements		
Lighting		Illuminance Category D ¹ with range of general illuminance required between 200 to 500 lux providing ambient and task lighting for performance of visual tasks of high contrast or large size
Color		Rejuvenation: small bodies of water found around site Uniform: low to medium contrast Refresh: cool, medium and light tones
Material Requirements		Easy to clean surfaces
Desired Character		A bright, awakening, fresh character with linear forms
Technology Requirements		
Heating/Cooling		Existing
Ventilation		Existing
Special (electrical)		
¹ Illuminance Categories and Illuminance Values for Generic Types of Activities in Interiors from the Lighting Handbook of the Illuminating Engineering Society of North America		

Table 10 - Functional, Technological and Spatial Requirements
Exercise Area

Communal Living

Required Square Footage: 150	Number Required	Average Dimensions for Square Footage of Room (LxWxH)	Special Features
Furniture/Fixtures/Equipment			
<i>Laundry</i>			
Washer	1	27"x38"x30"	Front load
Dryer	1	27"x38"x30"	Front load
Linear surface	/	25 linear feet	
Sensory Requirements			
Lighting		Illuminance Category D ¹ with range of general illuminance required between 200 to 500 lux providing ambient and task lighting for performance of visual tasks of high contrast or large size	
Color		Rejuvenation: small bodies of water found around site Uniform: low to medium contrast Refresh: cool, medium and light tones	
Material Requirements		Easy to clean surfaces	
Desired Character		A bright, awakening, fresh character with linear forms	
Technology Requirements			
Heating/Cooling	Existing		
Ventilation	Existing		
Special (electrical)			
¹ Illuminance Categories and Illuminance Values for Generic Types of Activities in Interiors from the Lighting Handbook of the Illuminating Engineering Society of North America			

Table 11 - Functional, Technological and Spatial Requirements
Laundry Area

Communal Living

Required Square Footage: 550			
Furniture/Fixtures/Equipment	Number Required	Average Dimensions for Square Footage of Room (LxWxH)	
<i>Workshop</i>			
Table Saw	1	90"x32"x32"	
Storage	/	150 cubic feet	
Linear surface	/	130 linear feet	
Sensory Requirements			
Lighting		Illuminance Category E ¹ with range of general illuminance required between 500 to 750 lux providing adjustable ambient and task lighting for performance of visual tasks of medium contrast or small size	
Color		Rejuvenation: small bodies of water found around site Uniform: low to medium contrast Refresh: cool, medium and light tones	
Material Requirements		Easy to clean surfaces	
Desired Character		A bright, awakening, fresh character with linear forms	
Technology Requirements			
Heating/Cooling		Existing	
Ventilation		Existing	
Special (electrical)		Outlets at 18" above floor	
¹ Illuminance Categories and Illuminance Values for Generic Types of Activities in Interiors from the Lighting Handbook of the Illuminating Engineering Society of North America			

Table 12 - Functional, Technological and Spatial Requirements
Workshop

Communal Kitchen/Dining

Required Square Footage: 500	Number Required	Average Dimensions for Square Footage of Room (LxWxH)	Special Features
Furniture/Fixtures/Equipment			
Range	1	24"x27"x36"	
Microwave storage	1	18"x12"x12"	
Dishwasher	1	25"x24"x35"	
Refrigerator	1	23"x28"x60"	
Wash basin	2	16"x18"x6"	Pull-out nose Single lever
Food prep area	/	30 linear feet	Various heights(34" to 36") Some pull-out
House ware/utensil storage	/	60 cubic feet	Built-in with adjustable shelving Overhead storage at 16" above counter top
Dry food storage	/	40 cubic feet	Built-in with adjustable shelving Overhead storage at 16" above counter top
Chair	4	23"x18"x38"	
Sensory Requirements			
Lighting		Illuminance Category E ¹ with range of general illuminance required between 500 to 750 lux providing adjustable ambient and task lighting for performance of visual tasks of medium contrast or small size	
Color		Nourishment: connected to wheat field scene Lightness: medium contrast Golden: overall warmth with cool accents	
Material Requirements		Stain resistant and durable	
Desired Character		A warm, bright space with an airy, open plan and linear forms	
Technology Requirements			
Heating/Cooling		Existing	
Ventilation		Existing with addition of fan over range	
Special (electrical)		Outlets at 18" above floor	
¹ Illuminance Categories and Illuminance Values for Generic Types of Activities in Interiors from the Lighting Handbook of the Illuminating Engineering Society of North America			

Table 13 - Functional, Technological and Spatial Requirements
Kitchen Area

Communal Kitchen/Dining

Required Square Footage: 500	Number Required	Average Dimensions for Square Footage of Room (LxWxH)	Special Features
Furniture/Fixtures/Equipment			
Table	5	96"x42"x30"	
Seating	40	23"x18"x38"	Mix of built-in and moveable Incorporation of bricks that match exterior
Hearth	1	30"x36"	
Sensory Requirements			
Lighting			
Color			
Material Requirements			
Desired Character			
Technology Requirements			
Heating/Cooling			
Ventilation			
Special (electrical)			
1. Illuminance Categories and Illuminance Values for Generic Types of Activities in Interiors from the Lighting Handbook of the Illuminating Engineering Society of North America			

Table 14 - Functional, Technological and Spatial Requirements
Dining Area

Communal Kitchen/Dining

Required Square Footage: 200	Number Required	Average Dimensions for Square Footage of Room (LxWxH)	Special Features
Furniture/Fixtures/Equipment Female restroom: ~100 sq ft			
Universal stall	1	66"x66"	
Wash station	1	48"x24"x30"	Single lever on wash basin Open under sink
Male restroom: ~100 sq ft			
Universal stall	1	66"x66"	
Wash station	1	48"x24"x30"	Single lever on wash basin Open under sink
Sensory Requirements			
Lighting	Illuminance Category D ¹ with range of general illuminance required between 200 to 500 lux providing ambient and task lighting for performance of visual tasks of high contrast or large size		
Color	Rejuvenation: small bodies of water found around site Uniform: low to medium contrast Refresh: cool, medium and light tones		
Material Requirements	Water resilient and durable		
Desired Character	A bright, awakening, fresh character with linear forms		
Technology Requirements			
Heating/Cooling	Existing		
Ventilation	Addition of exhaust fan		
Special (electrical)	Outlets at 18" above floor		
¹ Illuminance Categories and Illuminance Values for Generic Types of Activities in Interiors from the Lighting Handbook of the Illuminating Engineering Society of North America			

Table 15 - Functional, Technological and Spatial Requirements
Public Restrooms

Illuminance Categories and Illuminance Values for Interior Activities
by the Illuminating Engineering Society of North America

I. Illuminance Categories and Illuminance Values for Generic Types of Activities in Interiors				
Type of Activity	Illuminance Category	Ranges of Illuminances		Reference Work-Plane
		Lux	Footcandles	
Public spaces with dark surroundings	A	20-30-50	2-3-5	
Simple orientation for short temporary visits	B	50-75-100	5-7.5-10	General lighting throughout spaces
Working spaces where visual tasks are only occasionally performed	C	100-150-200	10-15-20	
Performance of visual tasks of high contrast or large size	D	200-300-500	20-30-50	
Performance of visual tasks of medium contrast or small size	E	500-750-1000	50-75-100	Illuminance on task
Performance of visual tasks of low contrast or very small size	F	1000-1500-2000	100-150-200	
Performance of visual tasks of low contrast and very small size over a prolonged period	G	2000-3000-5000	200-300-500	
Performance of very prolonged and exacting visual task	H	5000-7500-10000	500-750-1000	Illuminance on task, obtained by a combination of general and local (supplementary lighting)
Performance of very special visual tasks of extremely low contrast and small size	I	10000-15000-20000	1000-1500-2000	

Fig. 11-1. Continued

II. Continued			
Area/Activity	Illuminance Category	Area/Activity	Illuminance Category
Book repair and binding	D	Thermal copy, poor copy	F ³
Cataloging	D ³	Xerograph	D
Card files	E	Xerography, 3rd generation and greater	E
Carrels, individual study areas (see Reading)		Electronic data processing tasks	
Circulation desks	D	CRT screens	B ^{12, 13}
Map, picture and print rooms (see Graphic design and material)		Impact printer	
Audiovisual areas	D	good ribbon	D
Audio listening areas	D	poor ribbon	E
Microform areas (see Reading)		2nd carbon and greater	E
Locker rooms	C	Ink jet printer	D
Merchandising spaces		Keyboard reading	D
Alteration room	F	Machine rooms	
Fitting room		Active operations	D
Dressing areas	D	Tape storage	D
Fitting areas	F	Machine area	C
Locker rooms	C	Equipment service	E ¹⁰
Stock rooms, wrapping and packaging	D	Thermal print	E
Sales transaction area (see Reading)		Handwritten tasks	
Circulation (see chapter 18) ^B		#2 pencil and softer leads	D ³
Merchandise (see chapter 18) ^B		#3 pencil	E ³
Feature display (see chapter 18) ^B		#4 pencil and harder leads	F ³
Show windows (see chapter 18) ^B		Ball-point pen	D ³
Motels (see Hotels)		Felt-tip pen	D
Municipal buildings—fire and police		Handwritten carbon copies	E
Police		Non photographically reproducible colors	F
Identification records	F	Chalkboards	E ³
Jail cells and interrogation rooms	D	Printed tasks	
Fire hall	D	6 point type	E ³
Museums		8 and 10 point type	D ³
Displays of non-sensitive materials	D	Glossy magazines	E ¹³
Displays of sensitive materials (see chapter 17) ²		Maps	E
Lobbies, general gallery areas, corridors	C	Newsprint	D
Restoration or conservation shops and laboratories	E	Typed originals	D
Nursing homes (see Health care facilities)		Typed 2nd carbon and later	E
Offices		Telephone books	E
Accounting (see Reading)		Residences	
Audio-visual areas	D	General lighting	
Conference areas (see Conference rooms)		Conversation, relaxation and entertainment	B
Drafting (see Drafting)		Passage areas	B
General and private offices (see Reading)		Specific visual tasks ²⁰	
Libraries (see Libraries)		Dining	C
Lobbies, lounges and reception areas	C	Grooming	
Mail sorting	E	Makeup and shaving	D
Off-set printing and duplicating area	D	Full-length mirror	D
Spaces with VDTs (see chapter 15) ¹³		Handcrafts and hobbies	
Parking facilities (see chapter 24)		Workbench hobbies	
Post offices (see Offices)		Ordinary tasks	D
Reading		Difficult tasks	E
Copied tasks		Critical tasks	F
Ditto copy	E ³	Easel hobbies	E
Micro-fiche reader	B ^{12, 13}	Ironing	D
Mimeograph	D	Kitchen duties	
Photograph, moderate detail	E ¹³	Kitchen counter	
		Critical seeing	E
		Noncritical	D
		Kitchen range	
		Difficult seeing	E
		Noncritical	D

For footnotes, see end of table.

Fig. 11-1. Continued

II. Continued			
Area/Activity	Illuminance Category	Area/Activity	Illuminance Category
Kitchen sink		Safety	(see chapter 33)
Difficult seeing	E	Schools (see Educational facilities)	
Noncritical	D	Service spaces (see also Storage rooms)	
Laundry		Stairways, corridors	C
Preparation and tubs	D	Elevators, freight and passenger	C
Washer and dryer	D	Toilets and washrooms	C
Music study (piano or organ)		Service stations	
Simple scores	D	Service bays (see Part III, Industrial Group)	
Advanced scores	E	Sales room (see Merchandising spaces)	
Substand size scores	F	Show windows	(see chapter 18)
Reading		Stairways (see Service spaces)	
In a chair		Storage rooms (see Part III, Industrial Group)	
Books, magazines and newspapers	D	Stores (see Merchandising spaces and Show windows)	
Handwriting, reproductions and poor copies	E	Television	(see chapter 21)
In bed		Theatre and motion picture houses	(see chapter 21)
Normal	D	Toilets and washrooms	C
Prolonged serious or critical	E	Transportation terminals	
Desk		Waiting room and lounge	C
Primary task plane, casual	D	Ticket counters	E
Primary task plane, study	E	Baggage checking	D
Sewing		Rest rooms	C
Hand sewing		Concourse	B
Dark fabrics, low contrast	F	Boarding area	C
Light to medium fabrics	E		
Occasional, high contrast	D		
Machine sewing			
Dark fabrics, low contrast	F		
Light to medium fabrics	E		
Occasional, high contrast	D		
Table games	D		
Restaurants (see Food service facilities)			
III. Industrial Group			
Area/Activity	Illuminance Category	Area/Activity	Illuminance Category
Aircraft maintenance	(see chapter 20) ²¹	Mechanical	D
Aircraft manufacturing	(see chapter 20) ²¹	Hand	E
Assembly		Scales and thermometers	D
Simple	D	Wrapping	D
Moderately difficult	E	Book binding	
Difficult	F	Folding, assembling, pasting	D
Very difficult	G	Cutting, punching, stitching	E
Exacting	H	Embossing and inspection	F
Automobile manufacturing	(see chapter 20) ²¹	Breweries	
Bakeries		Brew house	D
Mixing room	D	Boiling and keg washing	D
Face of shelves	D	Filling (bottles, cans, kegs)	D
Inside of mixing bowl	D	Building construction (see Part IV, Outdoor Facilities)	
Fermentation room	D	Building exteriors (see Part IV, Outdoor Facilities)	
Make-up room		Candy making	
Bread	D	Box department	D
Sweet yeast-raised products	D	Chocolate department	
Proofing room	D	Husking, winnowing, fat extraction, crushing and refining, feeding	D
Oven room	D		
Fillings and other ingredients	D		
Decorating and icing	D		

For footnotes, see end of table.

Fig. 11-1. Continued

III. Continued			
Area/Activity	Illuminance Category	Area/Activity	Illuminance Category
Varnishing, vulcanizing, calendaring, upper and sole cutting	D	Drawing (gilling, pin drafting)	D
Sole rolling, lining, making and finishing processes	E	Combing	D ²⁴
Soap manufacturing		Roving (slubbing, fly frame)	E
Kettle houses, cutting, soap chip and powder ..	D	Spinning (cap spinning, twisting, texturing) ..	E
Stamping, wrapping and packing, filling and packing soap powder	D	Yarn preparation	
Stairways (see Service spaces)		Winding, quilling, twisting	E
Steel (see Iron and steel)		Warping (beaming, sizing)	F ¹⁶
Storage battery manufacturing	D	Warp tie-in or drawing-in (automatic)	E
Storage rooms or warehouses		Fabric production	
Inactive	B	Weaving, knitting, tufting	F
Active		Inspection	G ¹⁶
Rough, bulky items	C	Finishing	
Small items	D	Fabric preparation (desizing, scouring, bleaching, singeing, and mercerization) ...	D
Storage yards (see Part IV, Outdoor Facilities)		Fabric dyeing (printing)	D
Structural steel fabrication	E	Fabric finishing (calendaring, sanforizing, sueding, chemical treatment)	E ¹⁶
Sugar refining		Inspection	G ^{11, 16}
Grading	E	Tobacco products	
Color inspection	F	Drying, stripping	D
Testing		Grading and sorting	F
General	D	Toilets and wash rooms (see Service spaces)	
Exactng tests, extra-fine instruments, scales, etc.	F	Upholstering	F
Textile mills		Warehouse (see Storage rooms)	
Staple fiber preparation		Welding	
Stock dyeing, tinting	D	Orientation	D
Sorting and grading (wood and cotton)	E ¹⁶	Precision manual arc-welding	H
Yarn manufacturing		Woodworking	
Opening and picking (chute feed)	D	Rough sawing and bench work	D
Carding (nonwoven web formation)	D ²⁴	Sizing, planing, rough sanding, medium quality machine and bench work, gluing, veneering, cooperage	D
		Fine bench and machine work, fine sanding and finishing	E

IV. Outdoor Facilities

Area/Activity	Lux	Footcandles	Area/Activity	Lux	Footcandles
Advertising Signs (see Bulletin and poster boards)			Medium light surfaces ..	200	20
Bikeways (see chapter 24)			Medium dark surfaces ..	300	30
Building (construction)			Dark surfaces	500	50
General construction	100	10	Dark surroundings		
Excavation work	20	2	Light surfaces	50	5
Building exteriors			Medium light surfaces ..	100	10
Entrances			Medium dark surfaces ..	150	15
Active (pedestrian and/or conveyance)	50	5	Dark surfaces	200	20
Inactive (normally locked, infrequently used)	10	1	Bulletin and poster boards		
Vital locations or structures	50	5	Bright surroundings		
Building surrounds	10	1	Light surfaces	500	50
Buildings and monuments, floodlighted			Dark surfaces	1000	100
Bright surroundings			Dark surroundings		
Light surfaces	150	15	Light surfaces	200	20
			Dark surfaces	500	50
			Central station (see Electric generating stations—exterior)		

For footnotes, see end of table.

Fig. 11-1. Continued

V. Continued					
Area/Activity	Lux	Footcandles	Area/Activity	Lux	Footcandles
Professional	2000	200	Golf		
Amateur	1000	100	Tee	50	5
Seats during bout	20	2	Fairway ¹⁴	10-30	1-3
Seats before and after bout ..	50	5	Green	50	5
Casting—bait, dry-fly, wet-fly			Driving range		
Pier or dock	100	10	At 180 meters [200 yards] ¹⁴ ..	50	5
Target (at 24 meters [80 feet] for bait casting and 15 meters [50 feet] for wet or dry-fly casting) ¹⁴	50	5	Over tee area	100	10
Combination (outdoor)			Miniature	100	10
Baseball/football			Practice putting green	100	10
Infield	200	20	Gymnasiums (refer to individual sports listed)		
Outfield and football	150	15	General exercising and recreation	300	30
Industrial softball/football			Handball		
Infield	200	20	Tournament	500	50
Outfield and football	150	15	Club		
Industrial softball/6-man foot- ball			Indoor—four-wall or squash ..	300	30
Infield	200	20	Outdoor—two-court	200	20
Outfield and football	150	15	Recreational		
Croquet or Roque			Indoor—four-wall or squash ..	200	20
Tournament	100	10	Outdoor—two-court	100	10
Recreational	50	5	Hockey, field	200	20
Curling			Hockey, ice (indoor)		
Tournament			College or professional	1000	100
Tees	500	50	Amateur	500	50
Rink	300	30	Recreational	200	20
Recreational			Hockey, ice (outdoor)		
Tees	200	20	College or professional	500	50
Rink	100	10	Amateur	200	20
Fencing			Recreational	100	10
Exhibitions	500	50	Horse shoes		
Recreational	300	30	Tournament	100	10
Football			Recreational	50	5
Distance from nearest side- line to the farthest row of spectators			Horse shows	200	20
Class I Over 30 meters [100 feet]	1000	100	Jai-alai		
Class II 15 to 30 meters [50 to 100 feet]	500	50	Professional	1000	100
Class III 9 to 15 meters [30 to 50 feet]	300	30	Amateur	700	70
Class IV Under 9 meters [30 feet]	200	20	Lacrosse	200	20
Class V No fixed seating facilities	100	10	Playgrounds	50	5
It is generally conceded that the distance between the spectators and the play is the first consideration in determining the class and lighting requirements. However, the potential seating capacity of the stands should also be considered and the following ratio is suggested: Class I for over 30,000 spectators; Class II for 10,000 to 30,000; Class III for 5000 to 10,000; and Class IV for under 5000 spectators.			Quoits	50	5
Football, Canadian—rugby (see Football)			Racing (outdoor)		
Football, six-man			Auto	200	20
High school or college	200	20	Bicycle		
Jr. high and recreational	100	10	Tournament	300	30
			Competitive	200	20
			Recreational	100	10
			Dog	300	30
			Dragstrip		
			Staging area	100	10
			Acceleration, 400 meters [1320 feet]	200	20
			Deceleration, first 200 meters [660 feet]	150	15
			Deceleration, second 200 meters [660 feet]	100	10
			Shutdown, 250 meters [820 feet]	50	5
			Horse	200	20
			Motor (midget of motorcycle) ..	200	20

For footnotes, see end of table.

Fig. 11-1. Continued

II. Continued			
Area/Activity	Illuminance Category	Area/Activity	Illuminance Category
Drafting		Health care facilities	
Mylar		Ambulance (local)	E
High contrast media; India ink, plastic leads, soft graphite leads	T ₃ M ₃	Anesthetizing	E
Low contrast media; hard graphite leads	T ₃ M ₃	Autopsy and morgue ^{17, 18}	
Vellum		Autopsies, general	E
High contrast	T ₃ M ₃	Autopsy table	G
Low contrast	T ₃ M ₃	Morgue, general	D
Tracing paper		Museum	E
High contrast	T ₃ M ₃	Cardiac function lab	E
Low contrast	T ₃ M ₃	Central sterile supply	
Overlays ⁵		Inspection, general	E
Light table	C	Inspection	F
Prints		At sinks	E
Blue line	E	Work areas, general	D
Blueprints	E	Processed storage	D
Sepia prints	F	Corridors ¹⁷	
Educational facilities		Nursing areas—day	C
Classrooms		Nursing areas—night	B
General (see Reading)		Operating areas, delivery, recovery, and laboratory suites and service	E
Drafting (see Drafting)		Critical care areas ¹⁷	
Home economics (see Residences)		General	C
Science laboratories	E	Examination	E
Lecture rooms		Surgical task lighting	H
Audience (see Reading)		Handwashing	F
Demonstration	F	Cystoscopy room ^{17, 18}	E
Music rooms (see Reading)		Dental suite ¹⁷	
Shops (see Part III, Industrial Group)		General	D
Sight saving rooms	F	Instrument tray	E
Study halls (see Reading)		Oral cavity	H
Typing (see Reading)		Prosthetic laboratory, general	D
Sports facilities (see Part V, Sports and Recreational Areas)		Prosthetic laboratory, work bench	E
Cafeterias (see Food service facilities)		Prosthetic laboratory, local	F
Dormitories (see Residences)		Recovery room, general	C
Elevators, freight and passenger	C	Recovery room, emergency examination	E
Exhibition halls	C ¹	Dialysis unit, medical ¹⁷	F
Filing (refer to individual task)		Elevators	C
Financial facilities (see Banks)		EKG and specimen room ¹⁷	
Fire halls (see Municipal buildings)		General	B
Food service facilities		On equipment	C
Dining areas		Emergency outpatient ¹⁷	
Cashier	D	General	E
Cleaning	C	Local	F
Dining	B ⁶	Endoscopy rooms ^{17, 18}	
Food displays (see Merchandising spaces)		General	E
Kitchen	E	Peritoneoscopy	D
Garages—parking (see chapter 14)		Culdoscopy	D
Gasoline stations (see Service stations)		Examination and treatment rooms ¹⁷	
Graphic design and material		General	D
Color selection	F ¹¹	Local	E
Charting and mapping	F	Eye surgery ^{17, 18}	F
Graphs	E	Fracture room ¹⁷	
Keylining	F	General	E
Layout and artwork	F	Local	F
Photographs, moderate detail	E ¹³	Inhalation therapy	D
		Laboratories ¹⁷	
		Specimen collecting	E
		Tissue laboratories	F
		Microscopic reading room	D
		Gross specimen review	F

For footnotes, see end of table.

Image Copyright Consent

I TINA HELOMA / RAKENNUSTIETO grant permission to Vanessa Ilg to use the
(copyright representative printed name)

requested imagery from the book *Alvar Aalto Houses* in the fulfillment of her final practicum document for her Professional Masters Degree of Interior Design to be submitted to the University of Manitoba in January of 2009.

Date: 24.11.2009

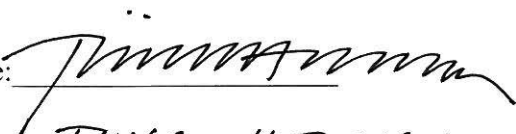
Signature: 
TINA HELOMA
RAKENNUSTIETO
PUBLISHING MANAGER

BOOK ALVAR AALTO HOUSES BY
JARI JETSONEN & MARKKU LAHTI
IMAGES ON PAGES 74-77
BY JARI JETSONEN

MARGHERITA SPILUTTINI

Schönlaterngasse 8 A-1010 Wien

Tel. + Fax: 0043-1-5125908

Email: office@spiluttini.com

www.spiluttini.com

I _____ grant permission to Vanessa Ilg to use the
(copyright representative printed name)

selected imagery from the book *In Detail: Housing for People of All Ages* in the fulfillment of her final practicum document for her Professional Masters Degree of Interior Design to be submitted to the University of Manitoba in January of 2009.

- Handling fee for usage of images from the Spiluttini archive for academic use: EUR 10,-.
- In case of publication please contact the Spiluttini office again for information on according copyright royalties.

All kinds of rights for use remain on the photographer's side. The usage by third parties is liable to pay costs and requests the allowance of the photographer. Liable are the terms and conditions of Austria's federal photographers' guild and those of its defence and recovery association of which the photographer owns a membership. Both can be found on www.photographer.at/vertrag.htm. The name of the photographer has to be credited obligatorily. Copyright infringement will be avenged accordingly.

Date: 25.11.2009

Signature: 