

# **A STUDY OF JOINT SLIP IN GALVANIZED BOLTED ANGLE CONNECTIONS**

**by**

**Nibong Ungkurapinan**  
B.Sc. Civil Engineering

A Thesis

Submitted to the Faculty of Graduate Studies of  
the University of Manitoba in Partial Fulfillment  
of the Requirements for the Degree of  
Master of Science in Civil Engineering

**Department of Civil and Geological Engineering**  
**University of Manitoba**  
**Winnipeg, Manitoba**  
© April, 2000



National Library  
of Canada

Acquisitions and  
Bibliographic Services

395 Wellington Street  
Ottawa ON K1A 0N4  
Canada

Bibliothèque nationale  
du Canada

Acquisitions et  
services bibliographiques

395, rue Wellington  
Ottawa ON K1A 0N4  
Canada

*Your file Votre référence*

*Our file Notre référence*

The author has granted a non-exclusive licence allowing the National Library of Canada to reproduce, loan, distribute or sell copies of this thesis in microform, paper or electronic formats.

The author retains ownership of the copyright in this thesis. Neither the thesis nor substantial extracts from it may be printed or otherwise reproduced without the author's permission.

L'auteur a accordé une licence non exclusive permettant à la Bibliothèque nationale du Canada de reproduire, prêter, distribuer ou vendre des copies de cette thèse sous la forme de microfiche/film, de reproduction sur papier ou sur format électronique.

L'auteur conserve la propriété du droit d'auteur qui protège cette thèse. Ni la thèse ni des extraits substantiels de celle-ci ne doivent être imprimés ou autrement reproduits sans son autorisation.

0-612-53234-8

Canada

**THE UNIVERSITY OF MANITOBA  
FACULTY OF GRADUATE STUDIES  
\*\*\*\*\*  
COPYRIGHT PERMISSION PAGE**

**A Study of Joint Slip in Galvanized Bolted Angle Connections**

**BY**

**Nibong Ungkurapinan**

**A Thesis/Practicum submitted to the Faculty of Graduate Studies of The University  
of Manitoba in partial fulfillment of the requirements of the degree  
of  
M.SC**

**NIBONG UNGKURAPINAN © 2000**

**Permission has been granted to the Library of The University of Manitoba to lend or sell copies of this thesis/practicum, to the National Library of Canada to microfilm this thesis/practicum and to lend or sell copies of the film, and to Dissertations Abstracts International to publish an abstract of this thesis/practicum.**

**The author reserves other publication rights, and neither this thesis/practicum nor extensive extracts from it may be printed or otherwise reproduced without the author's written permission.**

## **DEDICATION**

This thesis is dedicated to my family, and especially my parents, Nepon and Dr. Nongnuj. Without their encouragement, support, and generosity of spirit, I would never have come this far.

## **ABSTRACT**

Bolted joints in galvanized electric transmission line towers have not attracted much attention of the structural engineering research works in comparison to bolted joints in buildings and bridges. Joints in these towers are significantly different due to considerations such as constituent members carrying predominantly tensile or compressive forces, load transfer being of bearing type, direct connection of members by overlapping one another without gussets, centroidal axes of members not meeting at a point, and limitation of constituent member shapes to angles or flat bars. It is now known that due to omission of joint slip, the current analytical techniques applied to towers are inadequate as shown by their inability to predict deflections of a tower, and their inability to predict forces in a tower subjected to significant frost heave or permafrost ground movement. Hence a study on joint behavior with a special reference to joint slip of bolted joints in electric transmission line towers was considered beneficial and opportune.

The investigation consisted of a literature survey and an experimental study. The latter consisted of: (i) Test Series A, which dealt with a tower leg splice joint loaded in compression and incorporated nine joint tests; (ii) Test Series B, which dealt with a web bracing member joint loaded in tension and incorporated nine joint tests; (iii) Test Series C, which dealt with a joint of low load carrying capacity and high eccentricity loaded in compression and incorporated 36 joint tests; (iv) Test Series D, which dealt with bolt calibration by the turn-of-nut method and included 20 bolt tests; (v) Test Series E, which dealt with direct tension tests of bolts and included nine bolt tests; and (iv) Test Series F,

which dealt with tension tests on steel angle sections and included six tensile coupon tests.

The study resulted in developing mathematical expressions to describe slip and load-deformation behavior. Further, it concluded that construction clearance of 1/16 in. (1.59 mm) should be maintained in spite of its influence on joint slip generation, joint slip is significant and takes place during service loads, and joint deformation should be included in analytical methods dealing with transmission line towers.

## **ACKNOWLEDGEMENTS**

The author would like to express his deep gratitude to Dr. R. K. N. D. Rajapakse, Head of the Department of Civil and Geological Engineering, his advisor, for his guidance and assistance.

The author wishes to express his sincere thanks to Dr. R. Chandrakeerthy for his selfless assistance and valuable suggestions throughout his investigation and also to Dr. D. Polyzois for his guidance and helpful advice. This study could not be completed without their help.

The author is very grateful to Mr. S. B. Yue, P.Eng., Section Head of Structures, Transmission and Civil Department, Manitoba Hydro for providing useful information and advice. Further, the author would like to thank Dr. C. Q. Wu as his committee examiner. Special thanks are also extended to Mr. S. Sparrow for his continued and tireless assistance during the laboratory experimental program. In addition, the author also wishes to record his sincere gratitude to NSERC, which offered financial support for this investigation.

Lastly, the author would also like to pass his thankful appreciation to his friends, especially Kyung-min, for their support and to the Thai community in Winnipeg for providing a homely atmosphere during his stay.

## TABLE OF CONTENTS

	Page
DEDICATION.....	ii
ABSTRACT .....	iii
ACKNOWLEDGEMENTS.....	v
TABLE OF CONTENTS .....	vi
LIST OF TABLES .....	viii
LIST OF FIGURES .....	ix
LIST OF SYMBOLS .....	xv
CHAPTER 1: INTRODUCTION .....	1
1.1 GENERAL .....	1
1.2 THE IMPORTANCE OF JOINT SLIP IN BEARING TYPE CONNECTIONS .....	4
1.3 BACKGROUND TO THE INVESTIGATION AND OBJECTIVES .....	7
CHAPTER 2: THE LITERATURE SURVEY.....	9
2.1 INTRODUCTION .....	9
2.2 SHEAR TESTS ON BOLTED JOINTS CONNECTING PLATE MEMBERS.....	9
2.3 SHEAR TESTS ON BOLTED ANGLE CONNECTIONS.....	22
2.4 TORQUE TENSION TESTS ON BOLTS .....	24
2.5 DEVELOPMENT OF LOAD-DEFORMATION FORMULAE OF BOLTED JOINTS.....	26
2.7 CONCLUSIONS .....	27
CHAPTER 3: DEVELOPMENT OF THE EXPERIMENTAL INVESTIGATION .....	32
3.1 INTRODUCTION .....	32
3.2 VARIABLES CONSIDERED .....	32
3.3 SELECTION OF JOINTS FOR THE EXPERIMENTAL STUDY.....	33
3.4 CONTROL OF VARIABLES.....	35



3.5 EXPERIMENTAL INVESTIGATION .....	37
3.5.1 GENERAL .....	37
3.5.2 TEST SERIES A .....	38
3.5.3 TEST SERIES B.....	39
3.5.4 TEST SERIES C.....	39
3.5.5 TEST SERIES D .....	40
3.5.6 TEST SERIES E.....	40
3.5.5 TEST SERIES E.....	41
 CHAPTER 4: EXPERIMENTAL RESULTS AND ANALYSIS.....	42
4.1 INTRODUCTION.....	42
4.2 ANALYSIS OF RESULTS OF TEST SERIES A.....	42
4.3 ANALYSIS OF RESULTS OF TEST SERIES B .....	57
4.4 ANALYSIS OF RESULTS OF TEST SERIES C .....	67
4.5 COMPARISON OF RESULTS IN TEST SERIES A, B, AND C.....	87
4.6 ANALYSIS OF RESULTS OF TEST SERIES D.....	95
4.7 ANALYSIS OF RESULTS OF TEST SERIES E.....	99
4.8 ANALYSIS OF RESULTS OF TEST SERIES F.....	103
4.9 CONCLUSIONS .....	104
 CHAPTER 5: MAIN CONCLUSIONS AND RECOMMENDATIONS FOR FURTHER RESEARCH .....	141
5.1 MAIN CONCLUSIONS .....	141
5.2 RECOMMENDATIONS FOR FURTHER RESEARCH .....	146
 REFERENCES .....	148
APPENDIX A - TABLES.....	157
APPENDIX B - FIGURES.....	183

## LIST OF TABLES

Table	Page
3.1 Specimen numbers of Test Series A, B, and C.....	158
4.1 Important stages of load in specimens of Test Series A.....	159
4.2 Important parameters that define the load versus joint deformation response of specimens of Test Series A.....	160
4.3 Slip coefficient during frictional load transfer of specimens of Test Series A.....	161
4.4 Important stages of load in specimens of Test Series B.....	162
4.5 Important stages of deformation and elastic stiffness in specimens of Test Series B.....	163
4.6 Slip coefficient during frictional load transfer of specimens of Test Series B.....	164
4.7 Important stages of load in Test Series C.....	165
4.8 Important stages of deformation in Test Series C.....	167
4.9 Important elastic stiffness values in Test Series C.....	169
4.10 Slip coefficient values in Test Series C.....	171
4.11 Means of load values at various important stages of the loading process.....	173
4.12 Means of slip or deformation values at various important stages of the loading process.....	174
4.13 Means of elastic stiffness values at various important stages of the loading process.....	176
4.14 Load at commencement of slip as a ratio of load at other important loading stages of the loading process.....	177
4.15 Slip as a ratio of deformation at other important stages of the loading process....	178
4.16 Maximum load as a ratio of member load bearing capacity as well as bolt load bearing capacity.....	179
4.17 $A_n/A_g$ and $A_e/A_{ne}$ ratio of Test Series A, B, and C.....	180
4.18 Results of direct tension tests on bolts.....	181
4.19 Results of tension tests on steel angle sections.....	182

## LIST OF FIGURES

Figure	Page
3.1 Joints of transmission line towers selected for the study.....	184
3.2 Different settings of construction clearance at assembly .....	185
3.3 Details of a test specimen of Test Series A .....	186
3.4 Test Series A specimen in position for testing.....	187
3.5 MTS 445 Servo Hydraulic Testing Machine and National Instrument Data Acquisition.....	188
3.6 Details of a test specimen of Test Series B.....	189
3.7 Test Series B specimen in position for testing.....	190
3.8 Details of test specimens of Test Series C.....	191
3.9 Single bolt specimen of Test Series C in position for testing .....	192
3.10 Two-bolt specimen of Test Series C in position for testing .....	193
3.11 Three-bolt specimen of Test Series C in position for testing .....	194
3.12 Four-bolt specimen of Test Series C in position for testing .....	195
3.13 Two methods used for bolt calibration by turn-of-nut .....	196
3.14 A bolt specimen of Test Series E in position for the direct tension test.....	197
3.15 Details and location of test coupons from a angle steel angle section .....	198
4.1 A typical load versus total joint deformation diagram for Test Series A.....	199
4.2 Load versus total joint deformation diagrams for joints with maximum construction clearance (3.18 mm) at assembly of Test Series A .....	200
4.3 Load versus total joint deformation diagrams for joints with normal construction clearance (1.59 mm) at assembly of Test Series A .....	201
4.4 Load versus total joint deformation diagrams for joints set in bearing at assembly of Test Series A.....	202
4.5 Deformation on one leg of the top angle at failure .....	203
4.6 Deformation on the other leg of the top angle at failure .....	204
4.7 Movement of top and bottom angle to make direct contact with each other at failure and prior to failure.....	205

Figure	Page
4.8 Typical variations of load versus individual bolt row deformation and total joint deformation of specimens with maximum construction clearance (3.18 mm) at assembly of Test Series A (Specimen AM1).....	206
4.9 Typical variations of load versus individual bolt row deformation and total joint deformation of specimens with normal construction clearance (1.59 mm) at assembly of Test Series A (Specimen AN3) .....	207
4.10 Typical variations of load versus individual bolt row deformation and total joint deformation of specimens set in bearing at assembly of Test Series A (Specimen AB3) .....	208
4.11 Typical variations of load versus top joint deformation, bottom joint deformation , and total joint deformation of specomens with maximum construction clearance (3.18 mm) at assembly of Test Series A (Specimen AM1).....	209
4.12 Typical variations of load versus top joint deformation, bottom joint deformation , and total joint deformation of specomens with notmal construction clearance (1.59 mm) at assembly of Test Series A (Specimen AN3) .....	210
4.13 Typical variations of load versus top joint deformation, bottom joint deformation , and total joint deformation of specomens set in bearing at assembly of Test Series A (Specimen AB2).....	211
4.14 Typical of variations of deformation of portions of top, bottom, and splice angle with load for joints with maximum construction clearance (3.18 mm) at assembly of Test Series A (Specimen AM3) .....	212
4.15 Typical of variations of deformation of portions of top, bottom, and splice angle with load for joints with normal construction clearance (1.59 mm) at assembly of Test Series A (Specimen AN3).....	213
4.16 Typical of variations of deformation of portions of top, bottom, and splice angle with load for joints set in bearing at assembly of Test Series A (Specimen AB2)	214
4.17 Idealized load versus deformation diagram for joints with maximum construction clearance at assembly of Test Series A .....	215
4.18 Idealized load versus deformation diagram for joints with normal construction clearance at assembly of Test Series A .....	216

Figure	Page
4.19 Idealized load versus deformation diagram for joints set in bearing at assembly of Test Series A .....	217
4.20 A typical load versus total joint deformation diagram for Test Series A.....	218
4.21 Close up view of the crack on the gusset near its vertex.....	219
4.22 Cracking of angles in progress during a test (a) and a close up view of a typical crack (b).....	220
4.23 Failure with the gusset near vertex cracking on one side followed by cracking of both angles at their ends .....	221
4.24 Failure with the gusset near vertex cracking on both sides followed by cracking of the two angles one after ther other .....	222
4.25 Load versus total joint deformation diagrams for joints with maximum construction clearance (3.18 mm) at assembly of Test Series B .....	223
4.26 Load versus total joint deformation diagrams for joints with normal construction clearance (1.59 mm) at assembly of Test Series B .....	224
4.27 Load versus total joint deformation diagrams for joints set in bearing at assembly of Test Series B .....	225
4.28 Typical variations of load with individual bolt deformation and total joint deformation of specimens with maximum construction clearance (3.18 mm) at assembly of Test Series B (Specimen BM3) .....	226
4.29 Typical variations of load with individual bolt deformation and total joint deformation of specimens with normal construction clearance (1.59 mm) at assembly of Test Series B (Specimen BN3).....	227
4.30 Typical variations of load with individual bolt deformation and total joint deformation of specimens set in bearing at assembly of Test Series B (Specimen BB3) .....	228
4.31 Load versus angle and gusset deformation (Specimen BM2) .....	229
4.32 Idealized load versus deformation diagram for joints with maximum construction clearance at assembly of Test Series B.....	230
4.33 Idealized load versus deformation diagram for joints with normal construction clearance at assembly of Test Series B.....	231

Figure	Page
4.34 Idealized load versus deformation diagram for joints set in bearing at assembly of Test Series B .....	232
4.35 Effect of specimen end conditions on bolt shear .....	233
4.36 A typical load versus total joint deformation diagram for Test Series C .....	234
4.37 Load versus total joint deformation diagrams for single bolted joints with maximum construction clearance (3.18 mm) at assembly of Test Series C .....	235
4.38 Typical failure mode of specimens with 2 bolts (Test Series C) .....	236
4.39 Typical failure mode of specimens with 3 bolts (Test Series C) .....	237
4.40 Typical failure mode of specimens with 4 bolts (Test Series C) .....	238
4.41 Failure by bolt completely shearing apart in the re-tested specimen C1M1 (Test Series C).....	239
4.42 Load versus total joint deformation diagrams for single bolted joints with normal construction clearance (1.59 mm) at assembly of Test Series C .....	240
4.43 Typical load versus bolt deformation diagrams for joints with two bolts and normal construction clearance (1.59 mm) at assembly of Test Series C (Specimen C2N1) .....	241
4.44 Typical load versus bolt deformation diagrams for joints with three bolts and normal construction clearance (1.59 mm) at assembly of Test Series C (Specimen C3N2) .....	242
4.45 Typical load versus bolt deformation diagrams for joints with four bolts and normal construction clearance (1.59 mm) at assembly of Test Series C (Specimen C4N3) .....	243
4.46 Load versus total joint deformation diagrams for single bolted joints set in bearing at assembly of Test Series C .....	244
4.47 Typical load versus bolt deformation diagrams for joints with two bolts and maximum construction clearance (3.18 mm) at assembly of Test Series C (Specimen C2M2) .....	245
4.48 Typical load versus bolt deformation diagrams for joints with two bolts set in bearing at assembly of Test Series C (Specimen C2B3).....	246

Figure	Page
4.49 Typical load versus bolt deformation diagrams for joints with three bolts and maximum construction clearance (3.18 mm) at assembly of Test Series C (Specimen C3M1) .....	247
4.50 Typical load versus bolt deformation diagrams for joints with three bolts set in bearing at assembly of Test Series C (Specimen C3B1) .....	248
4.51 Typical load versus bolt deformation diagrams for joints with four bolts and maximum construction clearance (3.18 mm) at assembly of Test Series C (Specimen C4M3) .....	249
4.52 Typical load versus bolt deformation diagrams for joints with four bolts set in bearing at assembly of Test Series C (Specimen C4B2) .....	250
4.53 Typical variations of load and deformation between bolt holes in the angle sections of joints with two bolts (Specimen C2B2) .....	251
4.54 Typical variations of load and deformation between bolt holes in the angle sections of joints with three bolts (Specimen C3N2) .....	252
4.55 Typical variations of load and deformation between bolt holes in the angle sections of joints with four bolts (Specimen C4N3).....	253
4.56 Idealized load versus deformation diagram for joints with maximum construction clearance at assembly of Test Series C.....	254
4.57 Idealized load versus deformation diagram for joints with normal construction clearance at assembly of Test Series C.....	255
4.58 Idealized load versus deformation diagram for joints set in bearing at assembly of Test Series C .....	256
4.59 Variations of governing parameters with number of bolts .....	257
4.60 Variations of shear strength with number of bolts and joint length.....	258
4.61 Percentage load on each bolt of three-bolt joints at ultimate, at onset of plasticity, 50 percent of ultimate load, and 30 percent of ultimate load .....	259
4.62 Percentage load on each bolt of four-bolt joints at ultimate, at onset of plasticity, 50 percent of ultimate load, and 30 percent of ultimate load .....	260
4.63 Variation of tension versus turn-of-nut in torqued tension tests using the special rig .....	261

Figure	Page
4.64 Variation of tension versus turn-of-nut in torqued tension tests using the Skidmore-Wilhelm Hydraulic Bolt Calibrator.....	262
4.65 Failure modes of bolts tensioned by turn-of-nut method using the special rig.....	263
4.66 Bolts close to failure when tensioned by turn-of-nut method using the Skidmore-Wilhelm Hydraulic Bolt Calibrator.....	264
4.67 Load versus elongation diagrams of B33.4 grade 5 bolts tested in direct tension.	265
4.68 Load versus elongation diagrams of A325 bolts tested in direct tension .....	266
4.69 Two failure modes of direct tension tests on bolts.....	267
4.70 Stress versus strain diagrams of tension test coupons from steel angles.....	268
4.71 Tension test coupons from steel angles after failure and a close up of a typical specimen with galvanizing layer peeled off .....	269



## **LIST OF SYMBOLS**

$a_j$	=	a dimensionless exponent indicating the effect of the $j^{\text{th}}$ size parameter on the moment-rotation relationship
$A_g$	=	the gross area of steel angle or plate, $\text{mm}^2$
$A_{ne}$	=	the effective net area of steel angle or plate, $\text{mm}^2$
$A_s$	=	the shear area of the bolts, $\text{mm}^2$
$C_i$	=	constant
$C_j$	=	connection model parameters
$C_1$	=	the initial linear relationship between T and e
e	=	the strain (displacement or rotation)
$k_s, \mu$	=	slip coefficient
K	=	standardization factor
$K_1$	=	elastic stiffness, N/mm
l	=	connection length, mm
m	=	number of slip planes
M	=	connection moment, N-mm
$M_o$	=	initial moment, N-mm
n	=	the parameter defining the general nonlinear relationship between T and e
$p_j$	=	numerical value of $j^{\text{th}}$ size parameter
P	=	axial force in the member, kN
$P_s, P_{slip}$	=	slip load, kN
$R_b$	=	load resistance by bolt, kN
$R_h$	=	load carried by the portion of the angle between bolt holes, kN

$R_{kf}$	=	strain hardening rotational stiffness of connection
$T$	=	the stress (force or moment)
$T_i$	=	clamping bolt tension, kN
$T_o$	=	the maximum stress (force or moment)
$\alpha$	=	scale factor
$\delta$	=	deformation of the joint, mm
$\delta_b$	=	deformation of the bolt, mm
$\delta_h$	=	deformation of the portion of the angle between bolt holes, mm
$\Delta$	=	the axial deformation of the member at any load increment, mm
$\Delta_s$	=	the incremental slip, mm
$\Phi, \theta_r$	=	rotational deformation of the connection, radius
$\varphi$	=	connection rotation, radius

# **CHAPTER 1**

## **INTRODUCTION**

### **1.1 GENERAL**

The degree of consumption of electrical power is considered to be an important measure of prosperity in a country, and use of electrical power is an important segment of a country's economy. Hence the general problem of reducing all costs contributing to the expense of generating and distributing electric energy is of importance to any government. An area of possible cost reduction is in the use of economical guyed and self-supported electric transmission line towers, an aspect that has attracted little attention by structural engineers in comparison to other types of structures, such as buildings and bridges.

Transmission line towers are tall in order to provide the required ground clearance for the high voltage conductors. They must carry heavy electric cable loads, as well as considerable wind loads. This combination of live, dead, and wind loads favor the latticed form of construction for the towers. Member joints in latticed towers are quite different from other common structural joints because: (i) most members are eccentrically loaded at the joints; (ii) to minimize the use of gusset plates, members are often connected directly together; (iii) members are often limited to either angle sections or flat bars; (iv) the diameter of the bolts used is controlled by the member thickness; (v) members are assumed to carry either tensile or compressive force; and (vi) the centroidal axes of members are not coincident at the joints.

In steel construction, there are two types of connections, depending on the load transfer mechanism: bearing type, where the load is transferred through direct bearing of the fasteners on the joining members, and slip-critical or friction type, where the load is transferred through friction between the adjoining members. Friction type connections are commonly used in structures where repeated loads (cyclic) are predominant, like bridges. The difference between the two types of connections is that friction type requires that bolt be tightened to a predetermined value of pretension force, which will ensure that slip in the joint will not occur at service load. In bearing type connections, on the other hand, the bolts are only “snug tight” and slip at service load is not critical. Both friction type and bearing type connections, however, must be able to resist the factored loads.

Bearing type connections are preferred over friction type for electric transmission line towers for the following reasons: (i) ease of tower erection; (ii) as forces carried by the slender members of small cross section are low, the number of bolts required are also small and not much saving is possible by using friction type bolts; (iii) friction type connections are more expensive than bearing type connections; (iv) galvanized surfaces result in low values of slip coefficient ( $\mu$ ); (v) fatigue due to cyclic loading is not critical in towers and vibrations due to wind are minimized by limiting the slenderness ratio of long members and by inserting lock washers to prevent nut loosening; (vi) there has been some concerns related to the use of galvanized bolts and nuts in friction type connections; and (vii) high torques required in friction type connections may result in stripping of the galvanizing coating of the bolt shank and nut exposing them to corrosion. The use of bearing type connections in the construction of towers, which are subjected to cyclic

wind loading, implies that the joining members could slip at service load without compromising their structural integrity.

The importance of joint slip in connections of electric transmission line towers was first noted by structural engineers who observed, during full scale tests, that the actual lateral deformation of a tower is much larger than the deflection derived through structural analysis. Observations on towers subjected to considerable foundation movement due to frost heave or permafrost settlement, clearly showed the inability of current structural analytical methods to predict the induced member forces accurately. In some instances for towers still functioning well with large foundation movements, structural failure was predicted by analytical methods. This inability of current analytical techniques to predict failure prompted the present study, which is aimed at looking more closely at the mechanism of joint slip, and incorporating joint slip into the process of structural analysis.

The design of electric transmission line towers is undergoing rapid changes. Early designs were subject to mandatory full-scale tests and modifications to the design were carried out based on test results. With the issue of the American Society of Civil Engineers design guide (1988), full-scale tests are now considered optional. Work by Kitipornchai et al. (1994) has highlighted the need to express joint slip as a mathematical expression to enable incorporation of joint slip in the current structural analytical techniques in order to produce more realistic results for member capacity.

The issues discussed above underline the need for a critical examination of joint slip in bearing type connections used in latticed transmission line towers.

## **1.2 THE IMPORTANCE OF JOINT SLIP IN BEARING TYPE CONNECTIONS**

Slippage is the relative displacement of jointed members in a bolted joint that occurs when the connection is subjected to a shear load. This slippage occurs because of insufficient friction resistance between jointed members. The amount of slippage depends on the relative position of the bolts within the holes, which are oversized in order to provide an erection tolerance of  $1/16^{\text{th}}$  of an inch (1.59 mm.). For overhead transmission line structures, greater slippage is likely to occur as bolt diameters are small, members joined are thin, bearing type joints with a lower clamping force are used, and since galvanized faying surfaces have a lower coefficient of friction.

According to Winter (1956), bolt slippage consists of the clearance slip and the deformation slip. The theoretical maximum for the clearance slip is twice the hole clearance ( $1/16$  inch or 1.59 mm.) as the bolt shank may not be centrally located within the holes of the connecting members. This value is unlikely to be achieved in a multi-bolted joint as some bolts in a joint may go into bearing before the rest. The deformation slip is due to the bolt and the member distortion and changes with the applied load to the joint. Bolt slippage was found to be a function of: (a) structural loading; (b) workmanship; (c) nature of the faying surfaces; (d) corrosion; (e) clamping force in the bolt; (f) mechanical properties of the bolt; (g) mechanical properties of the members being joined; (h) bolt diameter; (i) shear stress of the bolt; (j) type of joint (bearing type or friction type); and (k) number of bolts in the joint (Kitipornchai et al., 1994; Kennedy, 1972; Lobb et al., 1971). Lobb et al. (1971) established that: (i) slippage is time-dependent, but does not exceed the value corresponding to that at full bearing with most of it taking place within 42 days after erection; (ii) slip is only indirectly related to stress

in the connected members; and (iii) bearing type connections are much less sensitive to faying-surface conditions than friction type since the load is predominantly carried by bearing.

Previous researchers have reported that the magnitude of bolt slippage observed was significant, but the actual extent reported varied from one researcher to another. Peterson (1962) reported that in tests involving full-scale transmission towers, approximately one-half of the measured maximum deflection at a joint was due to elastic deformation and approximately one-half was due to bolt slippage. Marjerrison (1968) reported that in several transmission tower tests, the deflection measured at the test was approximately three times the theoretical deflection based on a Williot diagram solution and that deformation in holes and in shanks of bolts accounts for part of the excessive movement. Kitipornchai et al. (1994) observed that the magnitude of the slippage might be as large as the elastic elongation of the connected members.

Kitipornchai et al. (1994) developed two models for bolt slippage. In model I, it was assumed that the two ends of a member, under either tension or compression, will slip relative to one another by an amount  $\Delta_s$  when the axial force in the member exceeds the loading needed to initiate slip,  $P_s$ . In this model, once a member starts to slip, no load increment is carried by the member until the assumed slip,  $\Delta_s$ , is completed. In model II, slippage was assumed to be a continuous process from the onset of loading. At any load increment, if the axial deformation of the member is  $\Delta$ , it is assumed that the incremental slip in the member,  $\Delta_s$ , may be expressed in the general form

$$\Delta_s = \Delta(\nu - \nu^m)$$

in which

$$\nu = \frac{P}{P_s} \frac{1}{\left[ 1 + \left( \frac{P}{P_s} \right)^n \right]^{\frac{1}{n}}}$$

where  $\Delta$  = axial deformation of the member at any load increment;

$P$  = axial force in the member (tension positive);

$m = 4$ ; and

$n = 6$ .

The drawbacks of these models were that: (a) in multi-bolted joints, it was assumed that every bolt slipped by the same amount at the same load level; and (b) the validity of the models was not verified through experimental studies.

Bolt slippage can affect a structure in many ways. It results in an increase in the total deflection of the structure. It increases the ability to cope with differential foundation settlement or heave, and reduces the structure's stiffness, thereby increasing its affinity to vibration and fatigue effects (Goel, 1994; Subramaniam et al., 1999). However, bolt slippage was found (Kitipornchai et al., 1994) not to significantly influence the ultimate strength of the structure.

Understanding the mechanism of bolt slippage, in steel bolted joints subjected to shear loads is very important, as reported by a number of researchers. For example, Kravitz et al. (1969) and Al-Bermani et al. (1992) pointed out that in full scale tests of transmission towers, the actual deflections and the theoretically predicted deflections do not match as bolt slippage is not accounted for in analytical methods currently in use. Knight et al. (1993) also reported that consideration of joint effects is important as they may lead to premature failures. While bolt slippage models have been developed, these have not been verified by experimental studies. As a result, structural analysis software



programs currently in use for transmission tower structures do not consider the effect of slippage at the bolted joints. This omission of the effect of bolt slippage may be quite critical in tower structures subjected to large differential settlements due to frost heave or permafrost settlement.

### **1.3 BACKGROUND TO THE INVESTIGATION AND OBJECTIVES**

Manitoba Hydro has a large number of guyed and self-supported latticed electric transmission line towers throughout Manitoba with many towers located in Northern regions where frost heave and permafrost settlements (Brown, 1973) are common. Tower structures are often subjected to differential movements, which could be as much as 6 in (150 mm). Such settlements can induce very high stresses in the structural members, and can lead to structural failure. As reported earlier, when current structural analysis software is applied to towers subjected to large foundation movement, results obtained are unrealistic. The current structural analysis software does not include the effect of bolt slippage at the joints. As a result, often structural failure of the tower is indicated, even when the tower is functioning normally.

In the absence of realistic models of analysis, full-scale tests are conducted when a new electric transmission line tower is designed. It was while conducting full-scale tests that design engineers first realized the importance of joint slip, since observed lateral deflection of the tower exceeded the theoretical deflection by a very large margin. However, very little research has been focused on this issue to date and not much information is available on joint slip of joints in electric transmission line towers. Hence, research on joint slip is of considerable importance and requires urgent attention.

The main objectives of this investigation are as follows: -

- 1) To identify the important variables that affect joint slip in steel galvanized bolted joints of latticed transmission line towers;
- 2) To select typical joint details from latticed electric transmission towers currently in service for an experimental study investigation;
- 3) To conduct an experimental investigation in order to determine the effect of bolt clearance, number of bolts, type of loading, and bolt arrangement on the joint slip and total joint deformation in common types of joints used in latticed electric transmission line towers;
- 4) To examine the performance of both friction type connections and bearing type connections containing lock washers;
- 5) To evaluate current methods used in predicting joint slip and total joint deformation;
- 6) To identify the distinct stages of the load-deformation response of a joint and, based on experimental evidence, to select appropriate parameters that can best describe load-deformation behavior;
- 7) To develop mathematical expressions to describe joint slip and joint deformation for joints in latticed electric transmission line towers;
- 8) To assess the need for modification of structural analytical techniques to account for joint slip in bearing type bolted joints used in latticed electric transmission line towers; and
- 9) To determine the influence of eliminating, minimizing, or increasing construction clearance at assembly of bearing type bolted joints.

## **CHAPTER 2**

### **THE LITERATURE SURVEY**

#### **2.1 INTRODUCTION**

The literature survey on behavior of bolted joints is presented in this chapter. Bulk of the previous research on bolted joint behavior was found to deal with bolted joints made with steel plates. In contrast, previous research studies on joint behavior of bolted joints made with steel angle sections were not many. Further, only a limited amount of research studies dealt with torque-tension tests on bolts, and development of load-deformation formulae for bolted joints. Finally, the chapter ends with the conclusions made from the literature survey.

#### **2.2 SHEAR TESTS ON BOLTED JOINTS CONNECTING PLATE MEMBERS**

Vasarhelyi, Beano, Madison, Lu, and Vasishth (1959) studied the effects of fabrication techniques on behavior of bolted joints. Variables considered were: (i) Tension/shear ratio (1.00:0.75, 1.00:1.00); (ii) Type of hole (drilled hole, punched hole); (iii) Faying surface (red lead painted, with mill scale); and (iv) Temperature (room, - 24°F). Number of replicates used was 2. Plates were 3/4 in. and 3/8 in. thick with 3/4 in. diameter bolts. All bolts were tightened to a torque of 320 ft-lbs. Specimens were instrumented with dial gages to measure bolt slip and slide-wire elongation gages to measure total elongation. Construction clearance of bolt holes was 1/16 in. The study concluded that punched holes affect significantly the efficiency of the joint, while misalignment and painting have a lesser effect.

Bendigo, Hansen, and Rumpf (1963) studied the behavior of long bolted joints with particular reference to length of the joint. Variables considered were: (i) Tension/shear ratio (1.00:1.09 to 1.65); (ii) Type of joint (butt joint, lap joint); (iii) Type of load transfer (friction type, bearing type); (iv) Pitch (2 5/8 in., 3 1/2 in.); (v) Length (3.5 in. to 52.5 in.); (vi) Width (5.84 in. to 15.10 in.); (vii) Grip or total thickness (2 in. to 8 in.); and (viii) Bolt tension (1/2 turn, 3/4 turn). Bolts used were 7/8 in. diameter A325 bolts and plates were 1 in. thick of A7 steel. Number of replicates used was nil. To attain thicker plate thicknesses either four plies or 8 plies of plate were used. Instrumentation was done with strain gages, a mechanical extensometer, and dial gages. Strain gages were used in the plates outside the connection to detect any eccentricity introduced by improper gripping and to pick up the onset of yielding of the gross section. The elongation of each pitch was measured along the edges of the plates by a hand held mechanical extensometer, which gave results valid for both the elastic and plastic range. Dial gages (0.001 in.) were used to measure overall elongation of the joint and relative movement or slip of the plates. All joints were tested in tension. Because the inherent eccentricity of lap joints caused them to bend, an external bracing system was used to restrain the rotation of the connection during tests. Although bolt failures did not occur in short joints, calculations of average shear stress and examination of intact joints indicated that bolt failure was imminent. Load at which the first bolt sheared has been recorded as the ultimate load of long joints, although in some cases a slightly greater load was required to cause failure of a succeeding bolt. The study concluded that, in long joints, the differential strains in the connected material caused the end bolts to shear (“unbuttoning” of the joint) before all bolts could develop their full shearing strength.

Yura and Frank (1985) developed a testing method to determine the slip coefficient for coatings used in bolted joints. Some noteworthy considerations found in their testing method are as follows: (i) The edges of the plates may be milled, as rolled or saw cut. Flame cut edged is not permitted. Any burrs, lips or rough edges should be filed or milled flat; (ii) Five replicates are specified for a test; (iii) Compression loading system should have an accuracy of 1.0 percent of the slip load; (iv) The relative displacement of the center plate and two outside plates must be measured. This displacement, called slip for simplicity, should be the average which occurs at the centerline of the specimen. This can be accomplished by using the average of two gages placed on the two exposed edges of the specimen, or by monitoring the movement of the loading head relative to the base. If the latter method is used, due regard must be taken for any slack that may be present in the loading system prior to application of the load. Deflections can be measured by dial gages or any other calibrated device, which has an accuracy of 0.001 in. (0.02 mm); (v) Slip gages should be engaged or attached after the application of a slight load so as to eliminate the initial specimen settling deformation from the slip readings; (vi) Loading rate should not exceed 25 kips (109 kN) per minute, or 0.003 in. (0.007 mm) of slip displacement per minute until the slip load is reached. The test should be terminated when a slip of 0.05 in. (1.3 mm) or greater is recorded; and (vii) Slip load should be defined as the appropriate of the following: (a) The maximum load, if this maximum occurs before a slip of 0.02 in. (0.5 mm) is recorded; (b) Load at which the slip rate increase suddenly; or (c) Load corresponding to a deformation of 0.02 in. (0.5 mm) when the load versus slip curve shows a gradual change in response.

Wallaert and Fisher (1965) investigated the double shear strength of A325, A354BC, A354BD, and A490 single bolt assemblies and the load-deformation relationships of them. Variables considered were: (i) Bolt type (A325 (weakest), A354BC, A354BD, A490 (strongest)); (ii) Plate type (A440, constructional alloy steel); (iii) Bolt diameter (7/8 in., 1 in.); (iv) Length of bolt (5.25 in., 5.50 in., 6.50 in., 9.50 in.); (v) Loading (compression, tension); (vi) Faying surface (with mill scale, lubricated); (vii) Clamping force (0 turn, 1/2 turn, 1 turn, 1 1/2 turns from snug position); (viii) Location of shear plane (both shear planes through shank, one shear plane through shank, both shear planes through thread); and (ix) End restraint in tension jig (no restraint, restrained by bolt in a slotted hole). Number of replicates used were 3, 5, 7, 9, and 18. Test jigs were assembled with the test bolts in bearing in order to minimize slip. Specimen was instrumented with two dial gages (0.0001 in.) attached to the main plates at the centerline of the bolt hole. The plungers of the dial gages rested on yokes tack-welded to the lap plates at the initial level of the dial gage support. This permitted measurement of relative movement of the centerline of a bolt caused by bolt shear, bolt bending, and bearing of plate holes. Load was applied to the specimen so that machine cross head movement was 0.01 in. (0.025 mm) per minute in the elastic range and 0.02 in. (0.05 mm) per minute in the inelastic range. The conclusions made were: (a) Shear strength of bolts tested in tension jigs was 10 percent lower than the same bolt types tested in compression jigs; (b) Bolt diameter did not affect the shear strength, but as bolt shearing area increases faster than bolt bearing area, the deformation at ultimate load is greater for 1 in. bolt than for 7/8 in. bolt; (c) Type of connected material had little or no influence on the shear strength, but material with a higher yield point gave smaller plate bearing deformations;

and (d) When lap plate prying action in a tension jig was minimized, the shear strength of bolts tested in a tension jig approaches that of a compression jig.

Vasarhelyi and Chen (1967) studied bolted joints with plates of different thickness. Three specimens were tested in which the variables considered were: (i) Nominal difference in thickness of main plates (none, 1/16 in., and 1/8 in.); (ii) Number of bolts (9 and 15); and (iii) Location of row of bolts nearest to thinner plate (1 1/2 in. to 4 1/2 in.). A butt lap joint was used where lap plates were 1/2 in. thick for all the specimens. A325 bolts of 3/4 in. diameter, 1 3/4 in. thread length and 1 3/4 in. shank length, were used. Fifteen bolts in five rows or nine bolts in three rows were used on either end of the butt lap joint. Instrumentation consisted of: (i) six dial gages at each side of the specimen to measure the slip; and (ii) three elongation gages made of three dial gages, with thin wire attached to the dial gages over a 32 in. gage length, mounted along three bolt lines on each face of the joint to ascertain major slip (refers to the first relative rigid body motion of jointed plates in which one whole plate unmistakably takes part). Tests were not replicated and no test was pursued to the point of plastic deformation or fracture. No specific loading rate was used, but the load was applied in 25 kips increments until slip (movement) and thereafter load increment was reduced to 15 kips or 10 kips until major slip occurred. The conclusions were: (a) Average slip reading at the major slip was about 0.04 in. (1.02 mm); and (b) The best way to improve resistance to slip, in a joint with difference of thickness in the main plates, is to increase the distance of the first row of bolts from the edge of the thinner plate.

Brookhart, Siddiqi, and Vasarhelyi (1968) investigated the influence of surface treatments on performance of high-strength bolted joints. Variables considered were: (i)

Type of specimen (2, 4 shear planes); (ii) Plate thicknesses (1 in. and 1/2 in., 1/2 in. and 3/8 in.); and (iii) Surface treatment (galvanized, zinc painted, metallized, vinyl-washed, rust-preventing paint, mill scale). Number of replicates varied from 3 to 4. Instrumentation and testing details were not reported. The conclusions were: (a) Average of coefficient of friction of galvanized joint was 0.23; (b) Hot-dip galvanizing produces a lower nominal coefficient of friction than that observed between dry mill scale surfaces; and (c) Since at 0.01 in. (0.25 mm) of slip, the load-slip curve becomes nearly flat, reflecting major slip (continued slip at constant load), the load needed to bring about a slip in the joint of 0.01 in. (0.25 mm) was taken as the slip load for all gradual slips. A shortcoming of this study is that tests were not done up to failure.

Allan and Fisher (1968) conducted a study on bolted joints with oversize or slotted holes. Variables considered were: (i) Type of joint (friction, bearing); (ii) Bolt tension (minimum tension, 1.5 times minimum tension); (iii) Use of washers (with, without washers); and (iv) Clearance of bolt hole (1/16 in., 1/4 in., 5/16 in., slotted parallel to line of loading, slotted perpendicular to line of loading). Three replicate specimens were used. Details of instrumentation were not reported. All specimens were fabricated using 1 in. diameter A325 bolts and 1 in. thick A36 steel plates. The plates had two lines of 1 in. diameter A325 bolts connecting four plies of plate at a pitch of 5 1/4 in. The faying surfaces were of clean mill scale. Each specimen had 8 bolts, two plies of main plate and 1 ply each of two side plates. Friction type specimens were loaded in 25 kips increments till major slip occurred and 10 kips increments during the series of minor slips that followed until joint went into bearing. Bearing type joints were loaded in 25 kips increments until initial slip and then loaded in 50 kips increments until



failure. The conclusions were: (a) Slip behavior of joints with oversize holes or slotted holes was similar to those with holes of nominal size with a series of small slips before the joint went into bearing; and (b) Slip coefficient of 1/4 in. oversize, 5/16 in. oversize, and slotted hole joints showed a decrease of 0%, 17%, and 22% to 33% of that of 1/16 in. oversize joints.

Fisher and Kulak (1968) reported a study on hybrid bolted butt splices made with plate materials of different steels. Variables considered were: (i) Bolt diameter (7/8 in., 1 1/8 in.); (ii) Number of bolts in line (4, 9, and 13); (iii) Joint length between outer bolts (10.5 in., 42 in., 63 in.); (iv) Plate width (5.26 in. to 7.96 in.); (v) Main plate thickness (2 in. to 4 in.); (vi) Plate material (A514, A36, A440); and (vii) Bolt type (A325, A490). No replicates were used in the tests. Instrumentation consisted of: (i) electrical resistance strain gages on edges of the plate at various locations along the length of the joint to evaluate the load transfer mechanism and to evaluate the plate loads throughout the joint; (ii) dial gages (0.0001 in.) to detect the slip between main and lap plate; and (iii) dial gages (0.001 in.) to measure overall elongation of the joint. Load was applied as slowly as practicable to minimize effects of dynamic loading till failure. The conclusions were: (a) The slip coefficient of steel (A36, A440, A514) blast cleaned with No.50 chilled steel grit is about 0.34; (b) The A325 bolt is not as suitable a connector for A514 steel as is the A490 bolt since A325 bolt cannot produce yielding on the gross section; and (c) At slip load, the plates moved relative to one another a little less than the amount of hole clearance.

Kennedy (1972) conducted a study on high strength bolted galvanized joints subject to fatigue loading. This study is of no direct relevance, but the following

information reported in it, was considered useful: (a) To prevent bearing before slip, tensile lap joints with middle plate and two side lap plates were assembled with holes aligned and with the bolts to the extreme side of the bolt hole toward the grip ends. Specimen had 4 bolts in 2 rows and 2 lines; and (b) Galvanized steel can be brittle due to hydrogen embrittlement caused during the acid pickling process by absorption of hydrogen into the steel matrix and due to formation of the brittle iron-zinc alloy layers during the galvanizing process.

Winter (1956) conducted tests on bolted connections in light gage steel. Although this study is of light gage steel, the following information in it was considered useful: (a) The torque corresponding to the "handtight" condition was obtained by experimentation with three persons who independently tightened bolts of different diameters, using wrench lengths recommended by bolt manufacturers' (from 9.75 in. for 1/4 in. bolts to 20 in. for 1 in. bolts). The torque corresponding to 5/8 in. diameter bolt was 50 ft-lbs; (b) Since it was desired to obtain information on initial slip as well as on deformation after bearing had been established, the majority of tests were made on duplicate specimens one of which was tightened with maximum initial clearance and the other with initial bearing; (c) The theoretical maximum amount of initial slip is equal to twice the hole clearance, and in multiple-bolt connections it will usually be only some fraction of the hole clearance in view of minor deviations from ideal dimensions, which will bring some bolts of a given connection into bearing while clearance is still maintained in others; and (d) Clearance slip, even when maximized as in these tests, usually represents only a small fraction of the total slip up to maximum load.

Vasarhelyi and Chang (1965) conducted a study on misalignment in bolted joints. Variables considered were: (i) Misalignment (no misalignment, five different misalignment patterns); and (ii) Faying surface (mill scale, red lead paint). Tests were not repeated. Instrumentation was similar to that of an earlier study (Vasarhelyi et al., 1959) by them. The misalignment was set in the central plate of the tension lap joint (with a central plate and two side plates) by drilling the specific holes in the central plate, which were 1/16 in. out of line with the others in the direction of the pull. The important findings were: (a) The slip in all joints with misaligned fasteners progresses gradually, indicating the presence in the joint, of a fastening element in bearing; (b) If fasteners are properly aligned, slip will bring the entire group in bearing almost simultaneously. If fasteners are out of alignment in a pattern symmetrical about the line of pull through the joint, the action will be similar to the one described above for the joint with no misalignment. However, the slip will be more gradual and without noticeable major initial slip; (c) Slip in joints with unsymmetrical patterns of misalignment occur more gradually than in one without misalignment, and the slips' development is not uniform. There seems to be no effect of the misalignment on the overall elongation of the joint; and (d) The presence of initially misaligned fasteners does not appear to reduced the ultimate load carrying capacity and joint efficiency significantly.

Fisher and Beedle (1965) investigated the design process currently used for the design of bearing type bolted joints. They reviewed the design process in the light of published experimental studies. Their important findings were: (a) The longer joints were not able to effect a complete redistribution of the load among all the bolts, because the end fasteners failed prematurely. This was not caused by any deficiency of the

fastener, but due to the accumulated differential strains between the main plate and the lap plates; (b) When plates were rigid and bolts plastic a better redistribution of forces occurred; and (c) When inelastic deformations occurred nearly simultaneously in the end of fasteners and in the plates, end bolts continued to pick up load at a faster rate than interior bolts.

Fisher and Rumpf (1965) developed an analytical method, based on iteration, to determine the load distribution in bolts of a bolted joint. The method uses ordinary mechanics and satisfies the condition of equilibrium (statics) and maintains continuity (compatibility) throughout the elastic and inelastic ranges. To use this method load-deformation curves up to failure of a bolt, main plate and lap plates with appropriate holes should be obtained by experimental study. Failure load is governed by the ultimate strength of the plate or a fastener.

Fisher (1965) conducted a study on behavior of fasteners and plates with holes. This experimental study resulted in developing mathematical expressions for load-deformation relationship of a plate with holes and of a bolt in shear, which are applicable to both elastic and inelastic regions.

Sterling and Fisher (1966) investigated the behavior of A440 steel joints connected by A 490 bolts. Variables considered were: (i) Pitch (2.63 in., 3.50 in., 5.25 in.); (ii) Number of bolts (8, 13, 19); (iii) Main plate thickness (2 in., 4 in.); and (iv) Ratio of plate area to shear area of bolts (1.22, 1.27, 1.30, 1.31, 1.92). No repeat tests were done. The instrumentation consisted of: (i) electric resistance strain gages attached to the edge of each plate to detect eccentricity of loading caused by uneven gripping as curvature in the joint; (ii) dial gages (0.001 in.) to measure joint elongation; and (iii) dial

gages (0.0001 in.) to measure slip between the main and lap plates. Steel plates were made of 1 in. plies of A440 steel and bolts used were 7/8 in. diameter A490 bolts set in holes 15/16 in. diameter. Load was applied in increments of 50 kips up to about 80% of the expected slip load and in increments of 10 kips up to major slip. Increment of loading after major slip was not given. The study concluded that: (a) in joints fastened by long bolts, the slippage of plates causes the bolt to bend, giving rise to an increased shearing area. This in turn produces an increase in the ultimate load and in ultimate deformation; and (b) average fastener shear strength is greatly influenced by increases in joint length causing a reduction in shear strength. The fastener pitch influences the shear strength mainly through its effect on joint length.

Kormanik and Fisher (1967) studied theoretically the bearing type bolted hybrid joints involving steels of different strengths. The variables were: (i) Ratio of net area of steel material to the total bolt shear area (0.53 to 1.70); and (ii) Joint length as reflected by the number of bolts in line (5 in. to 120 in.). The study was a further development of the Fisher and Rumpf method (1965) where equilibrium and compatibility equations were solved with the aid of the computer. Analytical relationships for tension behavior of a steel plate with holes and for a single bolt in double shear were developed based on the experimental work. The conclusions were: (a) The hybrid joints behaved similarly to homogeneous joints; (b) An increase in joint length produces a decrease in average shear strength; and (c) A decrease in the ratio of net area of steel to total bolt shear area produces a decrease in average shear strength.

Kulak and Fisher (1968) investigated the behavior of A514 steel joints fastened by A490 bolts. The variables were: (i) Bolt type (A325, A490); (ii) Bolt diameter (1 in.,

1 1/8 in.); (iii) Number of fasteners in line (4, 7, 13, 17, 25); (iv) Joint length (10.5 in., 21 in., 42 in., 56 in., 84 in.); and (v) Ratio of net area of either main or lap plate to total shear area of fastener (0.40 to 1.12). No replicates were used. Instrumentation used consisted of: (i) electric resistance strain gages attached to each edge of each plate just as it entered the joint, to detect possible eccentricity of loading caused by uneven gripping or curvature of the specimen; (ii) electric resistance strain gages, in large joints, placed across the width of lap plates at certain locations between fasteners to determine plate loads in those locations; (iii) dial gages (0.0001 in.) to measure the slip between main and lap plates; (iv) dial gages (0.001 in.) to measure movement of points one pitch length removed from each of the extreme fasteners (joint elongation); and (v) dial gages (0.001 in.) on the member as close as possible to the gripping heads to measure member elongation. All joints consisted of a main plate and two lap plates bolted together. The main findings were: (a) At the slip load, the main and lap plates moved relative to one another a little less than the amount of the hole clearance; (b) The specimens that failed by fracture of plates had a vary flat load-deformation curve near failure. In specimens that failed by bolt shear, the load-deformation curve approached the failure load on a much steeper slope because of their relatively greater plate area; and (c) Ultimate strength of the joint was dependent on joint length and relative plate-fastener proportions but independent of fastener diameter or pitch.

Chong and Matlock (1975) conducted a study on light gage steel bolted connections without washers. The variables studied were: (i) Steel sheet thickness (0.94 mm to 2.64 mm); (ii) Surface condition of sheet (painted, galvanized, black surface); (iii) Bolt diameter (5/16 in., 1/2 in., 3/4 in.); (iv) Number of bolts (1, 2, 3); (v) Bolt

arrangement (all bolts perpendicular or in line with load); (vi) Ratio of edge distance to bolt diameter (1.0 to 7.0); and (vii) Clamping torque (standard, twice the standard). Study was similar to that of Winter (1956) and the findings were: (a) Slip loads occurred between 40 to 80 percent of the ultimate load, with the lower percentages corresponding to thicker connecting sheets; (b) Deformation was not appreciable up to about 85 percent of the ultimate load, after which bolts started to tilt and warping of the free edges was noticeable; (c) Warping of free edges, which occurs towards the end of testing, has negligible effect on the load carrying capacity of the connection; and (d) Doubling the clamping torque did not affect the ultimate load, but slip loads increased with higher torque.

Zwerneman and Saleh (1996) studied the effect of burrs on the shear capacity of bearing connections. The variable in this study was burr height, which ranged from 0 to 0.176 inches. A total of 45 bearing connections were tested, where a single bolt was loaded in double shear. Joint consisted of a middle plate and two lap plates. All specimens were made with 3/4 in. diameter A325 bolts and A572 steel plate. Details of the test program and instrumentation were not reported. All nuts were tightened by hand to avoid compressing the large burrs prior to tests. The main findings were: (a) Failure was by shearing of the bolt, but ovaling of the bolt hole was never enough to be regarded as a bearing failure; (b) Increase of burr size caused only a minor decrease in shear strength; and (c) Required strength in bearing connections can be achieved without removing burrs from around bolt holes. A major shortcoming of this paper is that neither the details of the test program nor the test results were presented in full.

Lobb and Stoller (1971) investigated the behavior of bolted joints under sustained loading. This study, which dealt with a plate-angle connection, has little relevance and hence only the relevant findings are presented here. They were: (a) Galvanized surfaces caused somewhat more slip than other types of faying surfaces; (b) Joint slip is a time-dependent phenomenon; (c) The slip rate was linearly proportional to the fastener shear stress; and (d) Staggering the direction of bolt insertion did not improve the performance.

Fisher and Struik (1974) have reviewed bolted joints comprehensively and some important information, not presented previously, is described here: (a) An economical way of measuring slip is to measure the movement of different plates forming the joint at their centroidal lines of the bolt group perpendicular to the loading direction; and (b) Single bolt lap splices bend at the joint and shear failure of the fasteners were observed at an average fastener shear stress about 10 percent less than those for symmetric butt joints with similar material properties.

### **2.3 SHEAR TESTS ON BOLTED ANGLE CONNECTIONS**

Sakla, Wahba, and Madugula (1999) investigated spliced axially loaded single angle members in compression. This was a limited study where only six specimens were tested. Four specimens were tested with the splice joint, one specimen with a splice joint where packing bars were used to fill the 1/4 in. gap between top and bottom angles, and one specimen was one piece angle without any joint. The tested joint had 6 bolts of 5/8 in. diameter on each angle distributed among both legs. Bolts were tightened to a 150 in-lbs torque, which represented the snug tight condition. Instrumentation consisted of: (i) two dial gages at mid-height of the specimen to measure lateral deflection in



perpendicular directions; (ii) ten electric resistance strain gages positioned, three on center of one splice plate, three on center of the other splice plate, and remaining four on each leg of the angle approximately mid-way between joint and support to obtain the stress distribution; and (iii) thin layer of white wash applied to the specimen to detect high-yielding zones by observing the flaking off of the brittle coating. The main findings were: (a) There is no significant decrease in ultimate load between one-piece angle and the spliced angle; (b) Use of packing bars did not significantly increase the maximum compressive load carrying capacity; and (c) Use of splice angles, instead of splice plates will reduce the joint eccentricity. The main shortcoming of this study was the omission of the stiffness of the specimen from consideration due to non-measurement of either slip or axial deformation of the joint.

Kennedy and Sinclair (1969) studied the ultimate capacity of single bolted angle connections. Variables considered were: (i) End distance (3/4 in. to 1 3/4 in. in steps of 1/8 in.); (ii) Edge distance (5/8 in. to 1 3/8 in. in steps of 1/8 in.); (iii) Thickness (1/8 in., 3/16 in., 1/4 in.); and (iv) Material of angle (CSA G40.4, ASTM A36, CSA G40.6, CSA G40.8, RB 60). Test program details were not reported, so the number of replicates used could not be found. All the bolts were tightened to the maximum possible extent by hand using 14 in. ratchet wrench, as this was the method used in the field erection of tower structures. Instrumentation details were not presented clearly in the paper. The main findings were: (a) Failure in bearing occurs at a nominal bearing stress equal to approximately 4.5 times the yield stress; (b) The development of local stresses in the immediate neighborhood of the hole, equal to or greater than the yield stress, is not a reliable indication of approaching failure of the joint; and (c) Failure through either end

or edge is a distinct function of end and edge distance and can be predicted with the equations developed in this study.

## **2.4 TORQUE TENSION TESTS ON BOLTS**

Eaves (1978) investigated the effect of bolt lubrication on tightening characteristics of high strength bolts. Variables considered were: (i) Method of tightening (impact wrench, torque wrench); (ii) Bolt type (A325, A490); (iii) Nut type (A325, 2H); and (iv) Thread condition (clean, as received, lubricant 1, lubricant 2). Number of replicates used were 2 and 3. Instrumentation used was: (i) Skidmore-Wilhelm bolt tension calibrator to measure axial bolt load; and (ii) A C-frame fixture made of square tubing and carrying a dial gage (0.0001 in.) to measure bolt elongation. Main findings were: (a) Twist measured in the exposed threaded end of the bolt was a good indicator of the lubricant condition; (b) Of the two tightening methods considered, the impact method was found to give more consistent results; and (c) Two modes of failure observed were stripping of the thread and tensile failure of the bolt shank.

Kennedy (1972) conducted torque tension tests on galvanized A325 bolts, 1/2 in. diameter by 2 in. long. The galvanized bolts, nuts, and washers had a coating thickness of 0.086 mm  $\pm$  20 percent, 0.112 mm  $\pm$  20 percent, and 0.114 mm  $\pm$  25 percent respectively. They were galvanized to ASTM A153 class C and galvanized nuts were tapped 0.254 to 0.341 mm in diameter oversize after galvanizing. Variables considered were: (i) Bolt type (black, galvanized); and (ii) Lubrication (none, beeswax). Instrumentation used consisted of: (i) Skidmore-Wilhelm hydraulic calibrator to measure the tension induced in the bolt; (ii) C-frame extensometer consisting of a fixed anvil and

a mounted dial gage (0.0001 in.) to measure bolt elongation; and (iii) hardened steel balls 1/16 in. diameter set into the two ends of the bolts to take up the C-frame extensometer during elongation measurement. The main findings were: (a) To obtain consistent normal clamping forces, bolt should be tightened to an elongation of 0.308 mm; (b) Average clamping force on a galvanized lubricated bolt was 8 percent in excess of a black bolt; and (c) Black bolts and galvanized bolts lubricated with beeswax required 1 1/3 and 1 1/9 turns, respectively, to failure from snug position.

Brookhart, Siddiqi, and Vasarhelyi (1968) studied how the presence of protective coatings on bolt and nut threads affects the tightening of high strength bolts. Variables studied were: (i) Bolt type (black, galvanized); (ii) Type of torquing (manual, power); (iii) Lubricant (none, molecular graphite type lubricant); (iv) Bolt diameter (3/4 in., 1 in.); and (v) Bolt material (A325, A490). All the bolts were in the as-manufactured condition and the galvanizing was of ASTM A153 class C (1.25 oz.) with nuts overtapped 1/64 in. after galvanizing. Number of replicates used was 4. Instrumentation used was: (i) C-frame extensometer with 1/8 in. deep holes drilled in the center of head and shank ends of the bolt to measure bolt elongation; (ii) Skidmore-Wilhelm bolt calibrator to measure load in the bolt; and (iii) Pneumatic impact wrench (air pressure of 100 psi) to turn the nut. The main findings were: (a) Manual torquing is variable with torque required to attain a given clamping force varying as much as  $\pm 30$  percent; (b) The torque is increased by galvanizing by as much as 14 percent of the value obtained for black bolts; (c) Lubricant reduces the torque 20 percent or more in both bolt types; and (d) Power torquing applies a higher torque than manual torquing increasing it by 20

percent and 5 percent for galvanized and black bolts respectively. This increase is attributed to the vibration generated by the power wrench.

Tightening a nut (Fisher and Struik, 1974) induces torsional stresses in addition to tensile stresses and results in reduction of ultimate tensile load carried by the bolt as compared to ultimate load determined by a direct tension test. This average reduction is about 15 percent for A325 and A490 bolts.

## **2.5 DEVELOPMENT OF LOAD-DEFORMATION FORMULAE OF BOLTED JOINTS**

Research on joint deformation on structural behavior was first focused on steel joints in rigid frame structures (Frye et al., 1974; Jones et al., 1982; Lui et al., 1986; Chen et al., 1987; Goldberg et al., 1963; Romsted et al., 1970). Success achieved in this area of research led to the need for extension of this concept to bolted joints in tower type structures, which are predominantly under direct forces as opposed to bending moments. Although the importance of accounting for bolt slip was highlighted by many engineers (Petersen, 1962; Marjerrison, 1968; Kravitz et al., 1969) who conducted full scale tests on transmission line towers, due to complexity of the problem, it did not attract attention of research workers. Kittipornchai, Al-Bermani, and Peyrot (1994) were the first to address the issue of effect of bolt slippage on ultimate behavior of lattice structures and they proposed two models for bolt slippage.

The main shortcomings of these models are: (i) The models were not verified by experimental studies; (ii) Too much emphasis was given to slippage rather than total deformation of the joint; (iii) Variation of joint slip by factors such as construction

clearance in bolt holes, bolt arrangement, and number of bolts was ignored; and (iv) In model II, joint deformation is made a function of the member deformation rather than the member force.

## **2.6 CONCLUSIONS**

The conclusions made from the literature survey on bolted joints subject to shear are presented below.

Finger tight condition of nut tightening is considered as the tightness attained when a nut is tightened using the maximum effort of the fingers of the operative. Snug tight condition of nut tightening is considered as the tightness attained from the first few impacts of an impact wrench, or the full effort of a man using an ordinary spud wrench. Sometimes this condition is also referred to as the hand tight condition.

The variables that influence joint slip or deformation of bolted joints were: (a) load applied; (b) workmanship; (c) bolt properties; (d) angle properties; (e) extent of corrosion; (f) nature of faying surfaces; (g) bolt tightening method; (h) number of bolts; (i) pitch of bolts; (j) joint length; (k) the ratio of the effective net area of steel angle or plate,  $A_{nc}$ , and the shear area of the bolts,  $A_s$ ; (l) bolt diameter; (m) the ratio of the effective net area of steel angle or plate,  $A_{nc}$ , and the gross area of the steel angle or plate,  $A_g$ ; (n) end distance and edge distance; (o) type of bolt; and (p) location of the shear planes within the bolt length.

Number of replicates used in previous studies on bolted joint behavior varied from 0 (Winter, 1959; Bendigo et al., 1963; Vasarhelyi et al., 1967; Fisher et al., 1968; Vasarhelyi et al., 1965; Sterling et al., 1966; Kulak et al., 1968) to 18 (Wallaert et al.,

1965) with 3 as the more reasonable value, which is a balance between reliability and economy of the experimental program.

Most of the specimens were proportioned to accurately represent the actual joint arrangement in addition to the incorporation of small portions of the members framing into the joint.

Most common bolt diameters investigated were 7/8 in. and 1 in., which represent applications in bridge and building structures. Very few studies dealt with 5/8 in. diameter bolt, which is widely used in transmission line tower structures.

The most widely used method of slip measurement was to measure the relative movement between individual plates or angles that are connected at the joint. Dial gages (0.0001 in.) were widely used for slip measurement.

In friction type connections, slip load was determined from the load-deformation plot as one of the following: (i) Maximum load if it occurred before a total slip of 0.51 mm; (ii) Load at which deformation increases rapidly; and (iii) Load at a slip of 0.51 mm when load-deformation curve changes gradually. In bearing type joints, slip load was less complicated to determine as it was the load in (ii) above.

Bending at the joint of axially loaded lap joints due to internally developed eccentricity was well known, and Bendigo et al. (1963) used an external bracing system to restrain the rotation of the connection during tests.

For testing bolted joints, Yura and Frank (1985) specified that the loading system should have an accuracy of 1.0 percent of the slip load, and, for friction type joints, a loading rate of 25 kips (109 kN) per minute, or 0.003 in. (0.07 mm) of slip displacement per minute until slip load is reached. For bearing type joints, a loading rate between 0.25

in. per minute and 0.50 in. per minute (ASTM F606-90, 1993) should be maintained from start till failure.

In compression tests, the spherical head of the standard testing machine was considered (Polyzois et al., 1986) to ensure uniform compression along the specimen edge.

Shear strength of bolts (Wallaert and Fisher, 1965) tested in a tension jig was 10 percent lower than the same bolt types tested in a compression jig due to prying action of plates at the ends of the joint.

In friction type butt lap joints, with main plates of thickness differing by 0 to 1/8 in., made with 3/4 in. diameter bolts, average slip reading (Vasarhelyi and Chen, 1967) at major slip was about 1.02 mm.

Slip behavior of joints with oversize holes or slotted holes was (Allan and Fisher, 1968) similar to those with normal size holes. Slip coefficient of 1/4 in. oversize and 5/16 in. oversize joints showed a decrease of 0 and 17 percent of that of 1/16 in. oversize joints.

The manually applied torque at snug position for 5/8 in. diameter bolts was (Winter, 1956) reported to be 50 ft-lbs.

The theoretical maximum amount of initial slip is (Winter, 1956) equal to twice the hole clearance and in a multiple-bolted connection it will usually be only some fraction of the hole clearance in view of minor deviations from ideal dimensions, which will bring some bolts of a given connection into bearing while clearance is still maintained in others.

The slip in all joints with misaligned fasteners, progresses gradually indicating the presence, in the joint, of a fastening element in bearing (Vasarhelyi and Chang, 1965). If the fasteners are properly aligned or if fasteners are out of alignment in a pattern symmetrical about the line of force through the joint, slip will bring the entire bolt group in bearing simultaneously. Slip in joints with unsymmetrical patterns of misalignment occurs more gradually and development of slip may not be uniform.

In light gage steel connections without washers (Chong and Matlock, 1975) slip loads occurred at 40 to 80 percent of the ultimate loads with lower percentage for thicker sheets. Deformation was small up to about 85 percent of the ultimate load, after which bolts started to tilt and warping of the free edges was noticeable.

Canadian practice (Kennedy and Sinclair, 1969) in field erection of tower structures is to tighten bolts to the maximum possible extent manually using a 14 in. ratchet wrench.

In torque tension tests on bolts, the two mode of failure observed (Eaves, 1978) were stripping of the thread and tensile failure of the bolt shank.

Power torquing can apply (Brookhert et al., 1968) a higher torque than manual torquing due to vibration generated by the power wrench.

Tightening a nut (Fisher and Struik, 1974) induces torsional stresses in addition to tensile stresses and results in about 15 percent reduction of ultimate tensile load as compared to that determined by a direct tension test in black bolts.

Shortcomings of Kitipornchai et al. (1994) bolt slippage models are: (i) The models were not verified by experimental studies; (ii) Too much emphasis was given to slippage rather than total deformation of the joint; (iii) Variation of joint slip by factors



such as construction clearance in bolt holes, bolt arrangement, and number of bolts was ignored; and (iv) In the model based on continuous slip, joint deformation is made a function of the member deformation rather than the member force.

Increase of number of threads per nut (Pickford, 1981) from 6 (B33.4 grade 5) to 7 (A325) improves the stress distribution of the bolt end and the nut considerably.

When a bolt is tightened (Pickford, 1981), tensile stresses are developed throughout the bolt starting from zero at the free face of the bolt head, uniformly increasing to a high stress at bolt shank to bolt head joint, remaining constant at this high stress till the start of the thread, increasing to a still higher stress at the thread commencement and remaining constant at this stress in the threaded region up to the bearing face of the nut, reducing uniformly to zero at the free face of the nut, and continuing to be zero up to the protruding end of the bolt thread.

Relative typical magnitudes (Pickford, 1981) of the three reaction torques, which oppose the input torque applied to a nut are as follows: 10 percent inclined plane reaction torque, 40 percent thread friction reaction torque, and 50 percent nut friction reaction torque.

## **CHAPTER 3**

### **DEVELOPMENT OF THE EXPERIMENTAL INVESTIGATION**

#### **3.1 INTRODUCTION**

This chapter deals with issues related to the development of the experimental investigation. Important variables that affect joint behavior of bolted joints were considered. In order to attain the objectives of the study, these variables were controlled judiciously keeping some unchanged while varying the more influential variables. Three joint types were selected as these present the most prevalent in electric transmission line towers. Also, the details of each test series of the experimental investigation are presented in this chapter.

#### **3.2 VARIABLES CONSIDERED**

A bolted joint may transfer loads by shear in one direction, shear in several directions, tension and shear in one direction, or tension and shear in several directions. Since the most common form of load transfer of bolted joints in electric transmission line towers is shear in one direction, this mode of load transfer was selected for the study. Also, since load transfer by shear may involve bolts in single shear or bolts in double shear, both of these types of shear were considered in this study.

To a structural engineer, two aspects of bolted joint behavior are of interest: strength and slip or deformation. The main focus of this study is the deformation behavior of the bolted joint with particular reference to joint slip. Joint slip and deformation result from a complex interaction of many variables. The literature survey revealed that joint slip or deformation in connections of angle section is a function of the

following variables: (a) load applied; (b) workmanship; (c) bolt properties; (d) angle properties; (e) extent of corrosion; (f) nature of faying surfaces; (g) bolt tightening method; (h) number of bolts; (i) pitch of bolts; (j) joint length; (k) the ratio of the effective net area of steel angle or plate,  $A_{ne}$ , and the shear area of the bolts,  $A_s$ ; (l) bolt diameter; (m) the ratio of the effective net area of steel angle or plate,  $A_{ne}$ , and the gross area of the steel angle or plate,  $A_g$ ; (n) end distance and edge distance; (o) type of bolt; and (p) location of the shear planes within the bolt length. Hence, these variables were considered in the study and some were varied while others were kept constant.

### **3.3 SELECTION OF JOINTS FOR THE EXPERIMENTAL STUDY**

A large variety of joints are used in electric transmission line towers. Guyed lattice towers and self-supporting lattice towers are two common types of transmission towers. Among each of the above two types, a family of towers consisting of suspension towers, towers for various deflection angles, and dead end or anchorage towers are in use. Different types of electric transmission line towers used by Manitoba Hydro were reviewed and three types of joints were selected for the experimental study, as shown in Figure 3.1. The criteria used in selecting those joints were as follows: -

- 1) One of the selected joints should carry the highest compressive force developed in a joint of a leg in the tower being considered for study;
- 2) One of the selected joints should carry the highest tensile force developed in a joint of a web bracing member in the tower being considered for study;
- 3) One of the selected joints should carry a relatively small force developed in the tower being considered for study;

- 4) All the joints do not need to be selected from the same tower, but the joints should be already used in the towers;
- 5) The selected joints should represent the variation of eccentricity within a joint, typical of joints in a transmission line tower with eccentricity from none (see Figure 3.1 (b)) to a significant value (see Figure 3.1 (c));
- 6) Selected joints should not have too many bolts such that failure load is not more than a maximum load of 1,000 kN, which can be applied by a testing machine in the laboratory;
- 7) Number of bolts in the weakest joint can be increased in at least three steps without exceeding a maximum load of 1,000 kN, which can be applied by a testing machine in the laboratory;
- 8) Selected joints should encompass major jointing methods such as use of splice angle, gusset plate, and direct member to member contact;
- 9) Selected joints should cover bolts in single shear as well as bolts in double shear;
- 10) Selected joints should cover common joint layouts such as several bolts in a row as well as several bolts in a line;
- 11) Selected joints should include common member arrangements in a joint such as angle connected by one leg only as well as angle connected by both legs; and
- 12) Bolt shear capacity of the three joints should fall within a similar range to enable direct comparison, where applicable.

The joint, shown in Figure 3.1 (a), functions in compression or tension in an actual transmission tower. Tension will give more room for deflection as two angles will not contact each other and the same mode of load transfer will prevail till failure.

However, the more restrictive condition will be when loaded in compression as top and bottom angles may come into direct contact at some stage and change the mode of load transfer of the joint. Hence this joint was earmarked for testing in compression.

The joint, shown in Figure 3.1 (b), functions in compression or tension in an actual transmission tower. The weaker gusset and the end zones of the angles are more likely to be critically loaded when the joint is subjected to a tensile force. Hence this joint was earmarked for testing in tension.

The joint, shown in Figure 3.1 (c), functions in compression or tension in an actual transmission line tower. When loaded in tension, member ends at the joint open out producing tensile forces on the outer bolts by prying action, which results in a lower failure load compared to that when loaded in compression (Wallaert and Fisher, 1965). In order to simulate the condition that produces a higher failure load, which in turn induces a higher load on a bolt, this joint was earmarked for testing in compression.

### **3.4 CONTROL OF VARIABLES**

Variables relevant and considered in this study are listed in 3.2.

As the joint slip was primarily due to construction clearance that exists between bolt shank and bolt hole at assembly, this variable was considered the most important variable that requires close attention. Hence, construction clearance at assembly was varied to include three settings, as shown in Figure 3.2, namely: maximum construction clearance at assembly, normal construction clearance at assembly, and joints set in bearing at assembly. It was noted that construction clearance is sometimes referred to as fabrication and assembly conditions in the past literature.

Load applied was varied in each test gradually up to failure.

In the weakest joint to be tested (see Figure 3.1 (c)), number of bolts was varied to generate single bolted joints, two-bolt joints, three-bolt joints, and four-bolt joints.

Other relevant variables were not changed deliberately and their detailed treatment is summarized below: -

- 1) Workmanship was maintained at a level similar to that one would expect to see in construction of electric transmission line towers by employing a fabricator with considerable experience in servicing Manitoba Hydro using galvanized steel angles, galvanized bolts and accessories;
- 2) Bolt properties were not changed in the main joint tests, and bolts used were 5/8 in. (15.88 mm) diameter and complied with CSA B33.4 (1973) for B33.4 grade 5 bolts. This is the specification used by Manitoba Hydro to ensure the quality of the bolts;
- 3) Angle properties were not changed and the steel angle sections complied with CSA G40.20/40.21-98 (1998). The steel angle sections were galvanized after the holes had been drilled and prior to assembly. These are the specifications used by Manitoba Hydro for their steel angle sections;
- 4) Corrosion was not considered in this study and the materials used were in the “as delivered” condition;
- 5) Nature of faying surfaces was not varied in this study and galvanized surfaces were in the “as delivered” condition;
- 6) Bolt tightening was not varied and each bolt was tightened manually using torque wrench set to a torque of 84 ft-lbs (114.17 kN-mm). This is the actual torque used by Manitoba Hydro crews in erecting transmission line towers;

- 7) Pitch of bolts was not varied and was same as that used in Manitoba Hydro design drawings;
- 8) Joint length, the ratio of the effective area of steel angle or plate,  $A_{nc}$ , and the shear area of bolts,  $A_s$ , and bolt arrangement were varied for the weakest joint (see Figure 3.1 (c)) only, as number of bolts changed from one to four;
- 9) End distance, edge distance, bolt area at the shear plane corresponding to bolt shank area, and the ratio of the effective area of steel angle or plate,  $A_{nc}$ , and the gross area of the steel angle or plate,  $A_g$ , remained unchanged at values used in Manitoba Hydro design drawings;
- 10) Two joint type tested (see Figure 3.1 (a) and (c)) were in single shear while the other joint type (see Figure 3.1 (b)) was in double shear;
- 11) Bolt length in two types of joints tested (see Figure 3.1 (a) and (c)) was 1 1/2 inches (38.10 mm) while that of the other joint type (see Figure 3.1 (b)) was 1 3/4 inches (44.45 mm). All these values were same as those used in Manitoba Hydro design drawings; and
- 12) Two joint types (see Figure 3.1 (a) and (c)) were tested in compression and the other joint type (see Figure 3.1 (b)) was tested in tension.

### **3.5 EXPERIMENTAL INVESTIGATION**

#### **3.5.1 GENERAL**

The experimental investigation consisted of six test series. This section was presented in a manner that gives greater prominence to the joint tests of transmission line towers. However, tests were carried out by testing the material properties of bolts and

steel angles first. The joint tests were conducted later. The details of each test series are shown below.

### **3.5.2 TEST SERIES A**

In this test series tower leg splice joints (see Figure 3.1 (a)) were loaded in compression. Details of a specimen are shown in Figure 3.3. For each joint configuration defined by a set of variables, three replicate specimens were tested in order to check the consistency of the test results. Specimen numbers of the test series are shown in Table 3.1.

Each specimen was instrumented with linear variable displacement transducers (LVDTs) to monitor the displacement of members framing at the joint at each bolt location. The LVDTs enabled relative movement at each bolt location, as well as the whole joint, to be recorded with increasing load. The platen movement of the testing machine was also recorded. The load was applied via an MTS 445 Servo Hydraulic Testing Machine. The displacements and load were recorded by a National Instrument Data Acquisition system using a Pentium II PC and Labview software. Data were sampled every one second and plots of load versus deformations were on display during the testing. The loading rate was approximately 0.004 mm per second. A specimen of Test Series A in position for testing with the displacement transducers attached to it is shown in Figure 3.4. The MTS testing machine and the data acquisition system used for the tests are shown in Figure 3.5.



### **3.5.3 TEST SERIES B**

In this test series web bracing member joints (see Figure 3.1 (b)) were loaded in tension. Details of a typical specimen are shown in Figure 3.6. For each joint configuration defined by a set of variables, three replicate specimens were tested in order to check the consistency of the test results. Specimen numbers of this test series are given in Table 3.1.

The instrumentation and the testing procedure were similar to that of Test Series A, except that the applied load was in tension. Figure 3.7 shows a specimen of Test Series B in position for testing with displacement transducers attached to it.

### **3.5.4 TEST SERIES C**

In this test series joints of low load carrying capacity with large eccentricity (see Figure 3.1 (c)) were loaded in compression. These joints are found in situation such as a splice connection of a long diagonal bracing or a splice connection of leg in the top part of a transmission line tower. In order to study how the joint behavior changes with increasing number of bolts, four different joints were tested with the number of bolts increasing from one to four bolts. Details of a typical specimen are shown in Figure 3.8. As in the other two series, for each joint configuration three replicate specimens were tested in order to check the consistency of the test results. Specimen numbers of the test series are shown in Table 3.1.

The instrumentation and the testing were similar to that of Test Series A, except that the first two specimens were tested at a loading rate of 0.002 mm/sec. Figures 3.9 to

3.12 show specimens of each of the four different joints in position for testing with displacement transducers attached to them.

### **3.5.5 TEST SERIES D**

This test series dealt with the calibration of the bolts by the turn-of-nut method. Two different set-ups were employed for testing the bolts. One set-up involved a custom designed test rig, shown in Figure 3.13 (a) using an LW2316-100K washer load cell, supplied by Interface, Inc., to monitor the tensile force induced in the bolt as the nut was tightened. The other set-up involved a Skidmore-Wilhelm Hydraulic Bolt Calibrator, shown in Figure 4.13 (b).

In each set-up the tension force in the bolt was measured every 1/4 of a turn of the nut, starting from the “finger-tight” position of the nut, until failure of the bolt took place. The “snug-tight” position was also identified and the corresponding tensile load on the bolt was also recorded. In the first set-up, readings from the washer load cell were routed via a Measurements Group Vishay-2120 signal conditioning amplifier into a Validyne Data Acquisition card controlled by a 386 PC using Labtech Notebook software, which displayed and recorded the tensile load applied to the bolt at each stage of tightening. In the second set-up, the tensile force in the bolt at each stage of tightening was read off the load indicator dial.

### **3.5.6 TEST SERIES E**

This test series dealt with direct tension tests on bolts. These tests were conducted on a 60 kips Richle Hydraulic Universal Testing Machine (see Figure 3.14).

Bolt extension was measured with two LVDTs, at each loading step up to failure. Displacement and load readings from the testing machine were routed into a Labmaster Data Acquisition board controlled by a 486 PC using Labtech Notebook software, which displayed and recorded the tensile load induced and the corresponding displacement readings.

### **3.5.7 TEST SERIES F**

This test series dealt with standard tension coupon tests to determine the mechanical properties of the steel angle sections. Test coupons were obtained from the locations (see Figure 3.15) specified in CAN/CSA G40.20/40.21-98 (1998) and the dimensions of the coupons complied with ASTM A370 (1999). Test coupons were obtained from each of the three different angle sections used in this study.

Tension tests on test coupons were done on a 30 kips Baldwin Universal Testing Machine. Extension between gage points was measured with an MTS (model 623.12C-20) extensometer strapped to the specimen by rubber bands. Extension readings and load readings from the testing machine were routed into a Labmaster Data Acquisition board controlled by a 486 PC using Labtech Notebook software, which displayed and recorded the tensile load induced and the corresponding extension. After failure occurred in the test coupon, measurements were also made to determine the percent elongation and the percent reduction in area.

## **CHAPTER 4**

### **EXPERIMENTAL RESULTS AND ANALYSIS**

#### **4.1 INTRODUCTION**

This chapter presents the experimental results of the study along with the analysis of all the results. The results and analysis of the Test Series A, B, C, D, E, and F are dealt in separate sections. A comparison of results of Test Series A, B, and C is presented in section 4.5. The chapter ends with the conclusions drawn from the analysis of the results.

#### **4.2 ANALYSIS OF RESULTS OF TEST SERIES A**

In this test series all the bolts were in single shear and arranged on two vertical lines, one on each leg, parallel to the centroidal axes of angles. Initially, before top and bottom angles made direct contact, the top angle first transferred the load to the splice angle via bolt shear and then the splice angle transferred the load to the bottom angle via bolt shear.

Some typical load versus deformation diagrams and other useful data are shown in Figures 4.1 to 4.19. Test results are summarized in Tables 4.1 to 4.3.

The noteworthy observations made from the analysis of the results are presented below.

In this series of tests, centroidal axis of the specimen varied along the specimen, but it was constant in the following parts: (i) Top angle only; (ii) Top angle and splice angle; (iii) Splice angle; (iii) Splice angle and bottom angle; and (v) Bottom angle only.

Because of this variation, it was not possible to load the specimen in compression without eccentricity. However, eccentricity was minimized along the specimen by loading it along the centroidal axis of combined top angle and bottom angle sections. Hence, although the specimen is under a varying bending moment distribution, magnitudes of bending moments were small in comparison to compressive forces.

A typical load versus total joint deformation diagram is shown in Figure 4.1. The main differences among the various diagrams were observed to be the following: -

- (i) Extent of slip “Q” (see Figure 4.1) was highest for joints with maximum construction clearance at assembly, lowest and virtually non-existent for joints set in bearing at assembly. In joints with normal construction clearance at assembly the slip had an intermediate value; and
- (ii) Period of load transfer with top and bottom angles in direct contact with each other (see S in Figure 4.1) commences at a larger deformation for joints with maximum construction clearance at assembly, a smaller deformation for joints set in bearing at assembly, and an intermediate deformation for joints with normal construction clearance at assembly.

A typical load versus total joint deformation diagram (see Figure 4.1) was observed to have the following distinct segments: -

- (i) A segment of elastic frictional load transfer (ab);
- (ii) A segment of slip at a very reduced stiffness, or at an approximately constant load and thereafter at very reduced stiffness (bc);
- (iii) A segment of elastic load transfer by bolt bearing (cd);

- (iv) A segment of elastic load transfer (de) at a higher stiffness value, when the top angle makes direct contact with the bottom angle to transfer load directly as well as through the splice angle;
- (v) A segment of non-linear load transfer (ef) extending up to the maximum load, where the top angle (smallest angle) develops plastic deformations leading up to buckling; and
- (vi) A segment commencing from maximum load and leading up to failure of top angle (fg) where the top angle rapidly loses its load carrying capacity due to onset of buckling.

The specimen AB2 (set in bearing at assembly) showed a marked variation from typical load versus total joint deformation diagrams, by showing a slip region similar to those specimens with maximum or normal clearance at assembly (see Figure 4.4). This effect is attributed to the fact that only some bolts in a bolt group are inadvertently set in bearing at assembly due to inaccuracies in the shop production of bolt holes at specified spacings and locations.

Only one mode of failure was observed in the Test Series A. It consisted of the top angle slipping down to make direct contact with the bottom angle, followed by the development of plastic deformation in the top angle, the smallest angle, leading to failure by buckling. Figures 4.5 and 4.6 show the two legs of the top angle undergoing deformation leading to buckling failure, while Figure 4.7 shows the top and bottom angle in direct contact after failure.

Load at commencement of slip (see A in Figure 4.1) is defined as the load at which significant slip commences at a very reduced stiffness, or at an approximately

constant load and thereafter at a very reduced stiffness. Bolted joints, which were set in bearing at assembly except the faulty specimen AB2, showed no slip. Load per bolt values at commencement of slip were consistent as shown by the coefficient of variation of 10.90 percent (see Table 4.1).

Load at the end of slip (see B in Figure 4.1) was defined as the load at which the stiffness changes from a very reduced value to a greater value with the commencement of load transfer by bolts in bearing. Load per bolt values at the end of slip were somewhat variable, although not excessive, as shown (see Table 4.1) by a higher value of coefficient of variation of 22.81 percent. This variability can be attributed to unexpected changes in the clearance at assembly due to inaccuracies in the shop production of bolt holes at specified spacings and locations.

Load at the end of load transfer through the splice angle only (see C in Figure 4.1) was defined as the load at which mode of load transfer changes from via splice angle only to via splice angle and direct contact of top and bottom angles. Stiffness increases sharply at this point since area of cross section transferring compression load increases significantly. Load per bolt values at the end of load transfer through splice angle only, show (see Table 4.1) good consistency, as indicated by the coefficient of variation of 13.01 percent as imperfections at assembly have ceased to make an impact as all the bolts are in bearing at this stage.

Load at onset of plasticity (see D in Figure 4.1) is defined as the load at which elastic response of the joint changes to non-linear behavior due to the development of plastic bending in the top angle (smallest angle). Load per bolt values at the onset of plasticity are very consistent as shown by the coefficient of variation of 3.28 percent (see

Table 4.1). Lower coefficient of variation also indicates the load at onset of plasticity is not dependent on the condition of construction clearance at assembly.

Maximum load (see E in Figure 4.1) is defined as the highest load reached by the bolted joint during a test. Load per bolt values at maximum load are the most consistent as shown by the lowest coefficient of variation of 1.74 percent. The consistency of maximum load indicates that (i) maximum load is independent of the condition of construction clearance at assembly; and (ii) inherent ductility of the specimens ensures that any inadvertent deviations in fabrication and testing processes are evened out by plastic deformation.

Load at termination of the test (see F in Figure 4.1) has little significance as a distinct point of failure was not observed due to considerable deformation required for a plastic buckling failure. Point of failure was determined for convenience and uniformity to be the load at around 10 percent below maximum load.

Maximum deformation under frictional load transfer (see P in Figure 4.1) is defined as the maximum deformation that takes place during the frictional load transfer at the joint. It depends on the condition of the faying surfaces, clamping force, and actual area of contact. Large variations in specimens with normal clearance at assembly (see Table 4.2) can be attributed to variation in contact area of a few specimens due to interior fit of constituent parts due to inaccuracies during shop production.

Extent of slip (see Q in Figure 4.1) is defined as the slip that takes place at a very reduced stiffness, or at an approximately constant load and thereafter at a very reduced stiffness. No slip was observed (see Table 4.2) for joints set in bearing at assembly except the faulty specimen AB2. Those with maximum construction clearance gave the



highest extent of slip values, while those joints with normal construction clearance gave intermediate extent of slip values.

Deformation during load transfer through the splice angle only (see R in Figure 4.1) is defined as the joint deformation that occurs during elastic load transfer by bolts in bearing with the entire load transfer being affected via the splice angle. These deformation values show the least coefficient of variation among all other deformation values (see Table 4.2). This can be attributed to lack of influence of construction clearances, and other fabrication and testing irregularities as all bolts are in bearing at this stage.

Deformation during load transfer by direct contact between top and bottom angles as well as via splice angle (see S in Figure 4.1) is defined as the joint deformation that occurs during elastic load transfer by bolts in shear and elastic load transfer by top and bottom angles in direct contact. These values are variable (see Table 4.2) due to inconsistent nature of the onset of plasticity in the specimen due to material irregularities as well as inadvertent fabrication and testing irregularities.

Deformation between onset of plasticity and maximum load (see T in Figure 4.1) varies non-linearly with load. It is independent of construction clearance at assembly (see their mean values in Table 4.2) as bolts are in bearing at this stage too. Results show less consistency as indicated by a high coefficient of variation of 34.48 percent due to variability in the plastification process by the presence of inadvertent irregularities caused in fabrication and testing stages.

Deformation between maximum load and termination of test (see U in Figure 4.1) has little significance as a distinct point of failure was not observed due to considerable

deformation required for a plastic buckling failure. Point of failure was determined for convenience and uniformity to be the load around 10 percent below the maximum load.

Elastic stiffness before slip (see  $\theta_1$  in Figure 4.1) is caused by the frictional load transfer and the mobilization of a greater area of effective cross section to resist the load. For this reason, elastic stiffness before slip is greater than the elastic stiffness at any other stages of the loading process. Elastic stiffness before slip values show some variability, though not excessive, as shown by the coefficient of variation of 23.54 percent (see Table 4.2). This can be attributed to the fact that higher accuracy of measurement cannot be maintained as load at commencement of slip as well as the corresponding deformation are rather small.

Elastic stiffness during slip (see  $\theta_2$  in Figure 4.1) is either zero or very small. The values show remarkable consistency as shown by a low coefficient of variation of 14.37 percent (see Table 4.2). This confirms the fact that bolt clamping forces were uniformly applied throughout the test series. A small stiffness at slip was reported by the previous researchers (Vasarhelyi et al., 1959; Vasarhelyi and Chang, 1965; Fisher and Struik, 1974) due to misalignment of holes. This indicates that in some tests small inadvertent misalignments would have existed.

Elastic stiffness during load transfer only by the splice angle (see  $\theta_3$  in Figure 4.1) does not depend on construction clearance at assembly as all the bolts are in bearing at this stage. The values show remarkable consistency as shown by a low coefficient of variation of 15.51 percent (see Table 4.2).

Elastic stiffness during load transfer by direct contact between top and bottom angles as well as via splice angle (see  $\theta_4$  in Figure 4.1) does not vary with construction

clearance at assembly as all bolts are in bearing at this stage too. These values are the most consistent of the different types of stiffness observed in the loading cycle as shown by a coefficient of variation of 11.25 percent (see Table 4.2).

Elastic stiffness during unloading after termination of the test (see  $\theta_5$  in Figure 4.1) has little significance, as point of failure was determined for convenience and uniformity to be the load at around 10 percent below the maximum load. The high coefficient of variation of 20.61 percent (see Table 4.2) can be attributed to the fact that as the point of termination of test is rather arbitrary and not distinct, different specimens are at different stages of acquired permanent deformations, which give rise to varying extents of recoverable elastic deformation.

Slip coefficient before joints go into bearing was found (see Table 4.3) using the formula (Fisher and Struik, 1974):

$$P_{slip} = k_s m \sum_{i=1}^n T_i$$

where  $P_{slip}$  = Slip load;

$k_s$  = Slip coefficient;

$m$  = Number of slip planes; and

$\sum_{i=1}^n T_i$  = Sum of clamping bolt tensions.

In this entire test program the clamping force used per bolt is 35.67 kN, which is the usual value used by Manitoba Hydro during erection of their transmission line towers.

Kennedy (1972) reported a value of 0.153 for galvanized joints and Brookhart et al. (1968) reported values ranging from 0.19 to 0.25. These observed values were higher due to bigger washers used for the galvanized angle joints. The values show good

consistency as shown by the coefficient of variation of 7.99 percent (see Table 4.3). The joints set in bearing during assembly were excluded as there was no frictional load transfer in these joints.

Hot-dip galvanizing results (Fisher and Struik, 1974) in a lower frictional resistance of the faying surfaces. The low slip resistance of galvanized surfaces as compared to clean mill scale surfaces is caused by the presence of the softer zinc layer, which tends to act as a lubricant between faying surfaces. Slip coefficient was found to decrease with an increase in coating thickness. Further, very thin coatings 0.0005 to 0.001 in. (12.5 to 25  $\mu\text{m}$ ) also result in relatively low slip coefficients. The optimum slip performance is achieved when the coating thickness was between 0.002 to 0.004 in. (50 to 100  $\mu\text{m}$ ). Higher variability of slip resistance is often due to the variability in thickness of the metallic layer resulting from the galvanizing process. Fisher et al. (1974) have reported a coefficient of variation of 38.1 percent for joints with “as received” galvanized surfaces, and results of this test series show good tolerance in the thickness of the galvanized coating.

Figures 4.2, 4.3, and 4.4 show load versus total joint deformation diagrams for joints with maximum construction clearance, normal construction clearance, and joints set in bearing at assembly respectively. Basic shapes were similar except for the following: -

- (i) Extent of slip was highest for joints with maximum construction clearance at assembly, none for joints set in bearing at assembly except faulty joint AB2, and intermediate for joints with normal construction clearance at assembly; and

- (ii) Slip consisted of either slip at a very reduced stiffness, or at an approximately constant load and thereafter at a very reduced stiffness.

Figures 4.8, 4.9, and 4.10 show typical variations of individual bolt row deformation and total joint deformation with load for joints with maximum construction clearance, normal construction clearance, and joints set in bearing at assembly respectively. The following effects were observed in the results: -

- (i) Total joint deformation of a specimen was always greater than the deformation of each individual row of bolts;
- (ii) Most often the lowest deformation was recorded by the lowest row of bolts in the bottom angle (L4). This means that most often the lowest row of bolts in the bottom angle is least stressed and hence carries a lower load;
- (iii) Most often the highest deformation was recorded by the highest row of bolts in the top angle (L1). This means that most often the highest row of bolts in the top angle is stressed most and hence carries a higher load; and
- (iv) After reaching maximum load, deformation in either bolts at level 1 (L1), bolts at level 2 (L2), or bolts at level 3 (L3) of a specimen reverses and decreases as point of failure approaches. Most often this happens in lower row of bolts of the top angle (L2) in the case of joints with maximum construction clearance at assembly, and in bolts of the bottom angle (L3 and L4) in the case of joints with normal construction clearance or joints set in bearing at assembly. In the latter case greatest reversal occurs in the higher row of bolts of the bottom angle (L3). These can be attributed to the varying bending moments developed due to changing eccentricity along the specimen

during the buckling process dependent on the actual buckling profile of each specimen.

Figures 4.11, 4.12, and 4.13 show typical variations of top joint deformation, bottom joint deformation, and total joint deformation with load for joints with maximum construction clearance, normal construction clearance, and joints set in bearing at assembly respectively. The following effects were observed in the results: -

- (i) Total joint deformation of a specimen was greater than deformation of either top angle joint or bottom angle joint;
- (ii) Highest deformation was always recorded at the top angle joint, while lowest was at the bottom angle joint. This shows that although the shear load transferred through top angle joint and bottom angle joint is the same, the different bending moments induced and the mating leg sizes affect the deformations at top and bottom angle joints; and
- (iii) After reaching maximum load, deformation in the bottom angle joint reversed and decreased as point of failure approached in all joints with normal construction clearance at assembly and two of the three joints, AB1 and AB3, set in bearing at assembly. Note that specimen AB2 showed a slip (see Figure 4.4 and Table 4.2) indicating that it had some clearance at assembly and thus resembles joints with maximum clearance.

Figure 4.14, 4.15, and 4.16 show typical variations of deformation of portions of top angle, bottom angle, and splice angle between two bolt rows of top or bottom joints with load for joints with maximum construction clearance, normal construction clearance.

and joints set in bearing at assembly respectively. The following effects were observed in the results: -

- (i) In all the specimens, highest deformation was observed in the portion of top angle within the top joint, due to its smaller cross sectional area;
- (ii) Smallest deformation was observed in the portion of bottom angle within the bottom joint, due to its larger cross sectional area; and
- (iii) After reaching maximum load, most often, deformation in the portions of bottom angle (B3B4) within the bottom joint reversed and decreased as point of failure approached. This can be attributed to the development of bending moments in the bottom angle due to buckling profile undergone by the specimen.

Idealized curves are shown in Figures 4.17, 4.18, and 4.19 for joints with maximum construction clearance (3.18mm), normal construction clearance (1.59 mm), and joints set in bearing at assembly respectively. These are based on mean values observed during experimental studies. Variation beyond maximum load up to failure was omitted as previous researchers (Kitipornchai et al., 1994; Frye et al., 1974; Jones et al., 1982; Lui et al., 1986; Chen et al., 1987; Goldberg et al., 1963; Romsted et al., 1970; Al-Bermani et al., 1992; Cox, 1972) have also not considered this region. Following effects were observed in the results for three categories of construction clearance at assembly: -

- (i) Governing parameters ( $A$  and  $\theta_1$  in Figures 4.17 to 4.19) of the region of frictional load transfer were the same for all categories;
- (ii) There were ten governing parameters, namely  $A$ ,  $\theta_1$ ,  $B$ ,  $\theta_2$ ,  $C$ ,  $\theta_3$ ,  $D$ ,  $\theta_4$ ,  $E$ , and  $T$  (see Figures 4.17 to 4.19), for the categories of maximum construction

clearance, and normal construction clearance at assembly. The governing parameters B and  $\theta_2$  were not relevant for joints set in bearing at assembly and hence had only eight governing parameters (see Figure 4.19);

- (iii) Values of governing parameters A,  $\theta_1$ , C,  $\theta_3$ , D,  $\theta_4$ , E, and T (see Figures 4.17 to 4.19) were the same for all the three categories; and
- (iv) The governing parameter B varied for the categories of maximum construction clearance and normal construction clearance to give different values of slip. This parameter is not relevant for joints set in bearing at assembly as no slip occurred in them.

Past researchers have used following techniques to describe behavior of joints: -

- (i) On odd power polynomial (Frye and Morris, 1974)

$$\Phi = \sum_{i=1}^{\infty} C_i (KM)^i$$

where  $K = \prod_{j=0}^m p_j^{\alpha_j}$  ;

- (ii)  $\beta$ -spline model (Cox, 1972; Jones et al., 1982);
- (iii) Exponential model (Lui et al., 1986; Chen et al., 1987; Al-Bermani et al., 1992)

$$M = M_o + \sum_{j=1}^n C_j \left[ 1 - e^{\left( -\frac{\theta_r}{2j\alpha} \right)} \right] + R_{kj} |\theta_r|;$$

- (iv)  $T = \frac{C_1 e}{\left( 1 + \left| \frac{C_1 e}{T_o} \right|^n \right)^{1/n}}$  (Goldberg et al., 1963);



$$(v) \quad M = \frac{0.345K_1 l^2 (0.72l\varphi)^{0.4}}{(1 - 0.3l\varphi)^{1.4}} \quad (\text{Romstad et al., 1970}); \text{ and}$$

$$(vi) \quad \Delta_s = \Delta(\nu - \nu^n)$$

$$\text{where } \nu = \frac{P}{P_s} \frac{1}{\left[1 + \left(\frac{P}{P_s}\right)^n\right]^{\frac{1}{n}}} \quad (\text{Kitipornchai et al., 1994}).$$

Above methods used by previous researchers to develop mathematical expressions for load versus slip variation in the joint were tried and the best fitted curve was found to be: -

**Maximum construction clearance at assembly**

- (i)  $P = 263.45\delta$  for  $0.00 \leq \delta \leq 0.16$ ;
- (ii)  $P = 20.99(\delta - 0.16) + 43.28$  for  $0.16 \leq \delta \leq 3.71$ ;
- (iii)  $P = 43.65(\delta - 3.71) + 117.77$  for  $3.71 \leq \delta \leq 5.97$ ;
- (iv)  $P = 86.55(\delta - 5.97) + 216.40$  for  $5.97 \leq \delta \leq 6.76$ ; and
- (v)  $P = 44.97(\delta - 6.76)^3 - 147.79(\delta - 6.76)^2 + 87.73(\delta - 6.76) + 285.15$   
for  $6.76 \leq \delta \leq 7.12$ ;

where  $P$  = Load on the joint in kN; and

$\delta$  = Deformation of the joint in mm;

**Normal construction clearance at assembly**

- (i)  $P = 263.45\delta$  for  $0.00 \leq \delta \leq 0.16$ ;
- (ii)  $P = 20.99(\delta - 0.16) + 43.28$  for  $0.16 \leq \delta \leq 1.89$ ;
- (iii)  $P = 43.65(\delta - 1.89) + 79.49$  for  $1.89 \leq \delta \leq 5.03$ ;
- (iv)  $P = 86.55(\delta - 5.03) + 216.40$  for  $5.03 \leq \delta \leq 5.82$ ; and

$$(v) \quad P = 44.97(\delta - 5.82)^3 - 147.79(\delta - 5.82)^2 + 87.73(\delta - 5.82) + 285.15$$

for  $5.82 \leq \delta \leq 6.18$ ;

where  $P$  = Load on the joint in kN; and

$\delta$  = Deformation of the joint in mm;

**Set in bearing at assembly**

$$(i) \quad P = 263.45\delta \quad \text{for } 0.00 \leq \delta \leq 0.16 ;$$

$$(ii) \quad P = 43.65(\delta - 0.16) + 43.28 \quad \text{for } 0.16 \leq \delta \leq 4.13 ;$$

$$(iii) \quad P = 86.55(\delta - 4.13) + 216.40 \quad \text{for } 4.13 \leq \delta \leq 4.92 ; \text{ and}$$

$$(iv) \quad P = 44.97(\delta - 4.92)^3 - 147.79(\delta - 4.92)^2 + 87.73(\delta - 4.92) + 285.15$$

for  $4.92 \leq \delta \leq 5.28$  ;

where  $P$  = Load on the joint in kN; and

$\delta$  = Deformation of the joint in mm.

Feasibility of interpolation or extrapolation of the load-deformation relationship for similar joints with less or more number of rows of bolts was considered. Results of Test Series C (see 4.4) indicate that the load-deformation diagrams of joints can be interpolated or extrapolated for joints similar in configuration but differing in number of bolts. Hence interpolation or extrapolation of load-deformation relationship for similar joint configurations can be recommended and further research is necessary to obtain regression equations of the governing parameters. This requires further testing of specimens with number of bolt rows increased or decreased in this type of joint.

### **4.3 ANALYSIS OF RESULTS OF TEST SERIES B**

In this test series bolts were in double shear, and the double angles and gusset of each joint were in tension.

Some typical load versus deformation diagrams and other useful data are shown in Figures 4.20 to 4.34. Test results are summarized in Tables 4.4 to 4.6.

The noteworthy observations made from the analysis of the results are presented below.

In this series of tests, because of the symmetry about the central vertical plane, all the bolts were loaded in pure shear, and the angles and the gusset were loaded in tension.

A typical load versus total joint deformation diagram is shown in Figure 4.20. The main differences between different diagrams obtained for each specimen were observed to be as follows: -

- (i) Length of slip “P” (see Figure 4.20) was highest for maximum construction clearance at assembly, lowest and virtually non-existent for bearing, and an intermediate value for normal construction clearance at assembly; and
- (ii) Portions “ef” and “gh” showed kinks if either the gusset developed a second crack or the two angles cracked one after the other.

A typical load versus total joint deformation diagram (see Figure 4.20) was observed to have the following distinct segments: -

- (i) A segment of elastic frictional load transfer (ab);
- (ii) A segment of slip at approximately constant load or very reduced stiffness (bc);
- (iii) A segment of elastic load transfer by bolt bearing (cd);

- (iv) A segment of non-linear load transfer extending up to the maximum load, where the portion of the gusset between vertex of the gusset and the first bolt hole undergoes plastic tensile deformation (de);
- (v) A segment commencing from maximum load and leading up to failure of load transfer of the bolt closest to the vertex of the gusset, due to cracking of the gusset between bolt hole and exterior edge, either on one side or both sides (ef). If both sides of the gusset cracked one after the other, an additional kink was also developed in the segment “fg”;
- (vi) A segment of non-linear load transfer, at a very mild slope, extending up to a second peak of the load where the portion of the angle between the end face of the angle and its closest bolt hole undergoes plastic deformation where bulging can be seen by the naked eye (fg); and
- (vii) A segment (gh) commencing from second peak of the load and leading up to failure of load transfer of the bolt closest to the end face of the angle due to cracking of the angle between bolt hole and end face of the angle, either on one angle or both angles. If the two angles cracked one after the other, an additional kink was also developed in the segment “gh”.

This test series gave remarkably consistent test results in comparison to those of Test Series A and C, because of symmetrical nature of the loading with no eccentricities and the absence of buckling effects, which are variable and influenced by local imperfections in the specimens.

Following modes of failure were observed in the Test Series B: -

- (i) Specimens BM1, BM2, BM3, and BN3 failed with the gusset near vertex cracking (see Figure 4.21) on one side followed by cracking of both of the angles (see Figure 4.22) at their ends simultaneously (see Figure 4.23);
- (ii) Specimens BN2 and BB3 failed with the gusset near vertex cracking on one side followed by cracking of the two angles at their ends one after the other (see Figure 4.23); and
- (iii) Specimens BN1, BB1, and BB2 failed with the gusset near vertex cracking on both sides followed by cracking of the two angles at their ends one after the other (see Figure 4.24).

Load at commencement of slip (see A in Figure 4.20) is defined as the load at which significant slip takes place at approximately constant load or at a very reduced stiffness. Bolted joints, which were set at bearing during assembly, showed no initial slip. Values of equivalent single shear load per bolt at commencement of slip were very consistent (see Table 4.4) except for the high value of BM1 specimen. However, even this high value does not make the coefficient of variation (9.96 percent) large. This high value at commencement of slip of BM1 specimen is also associated with a low extent of slip (see BM1 in Figure 4.25) indicating that fabrication errors would have led one bolt to be near bearing while the other bolt to be at less than the maximum construction clearance at commencement of the test. As the first specimen to be tested in this series, it was repeatedly mounted and dismounted from the end attachments of the testing machine to get it correctly in position, and in this process above error would have occurred.

Load at onset of plasticity (see B in Figure 4.20) is defined as the load at which elastic response of the joint changes to non-linear behavior due to development of plastic

deformation at the vertex of the gusset. Values of equivalent single shear load per bolt at onset of plasticity are consistent (see Table 4.4) as shown by their low coefficient of variation (9.14 percent).

Maximum load (see C in Figure 4.20) is defined as the highest load reached by the bolted joint during a test. Values of equivalent single shear load per bolt at maximum load show the greatest consistency (see Table 4.4) as shown by the very low value of coefficient of variation (2.07 percent). Their mean value (51.27 kN) is lower than the specified single shear load for a bolt with a diameter of 5/8 inches (16 mm) in accordance with CAN/CSA-S16.1-94 (1995) (72.5 kN), since in multiple bolt joints, bolts may not share the load equally.

Extent of slip (see P in Figure 4.20) is defined as the slip that takes place approximately at constant load or at very reduced stiffness. No slip was observed (see Table 4.5) for joints, which were set in bearing during assembly. Those joints with maximum construction clearance gave the highest values of extent of slip, while those joints with normal construction clearance gave intermediate values. Neither the joints with maximum construction clearance nor the joints with normal construction clearance slipped to their respective maximum possible extents of 3.18 or 1.59 mm due to restrictions caused by fabrication tolerances when more than two members mate at the joint.

Deformation between end of slip and onset of plasticity (see Q in Figure 4.20) varies elastically with the load, and most bolted joints in service function in this range. It is independent of construction clearance at assembly as bolts are in bearing at this stage. Results show less consistency (see Table 4.5) as indicated by the coefficient of variation

of 21.62 percent, due to variability in the local imperfections of the gusset area near the vertex, which yielded first.

Deformation between onset of plasticity and maximum load (see R in Figure 4.20) varies non-linearly with load. It is independent of construction clearance at assembly as bolts are in bearing at this stage too. Results show better consistency (see Table 4.5) as indicated by the coefficient of variation of 15.58 percent. This can be attributed to the fact that stress concentrations, caused by the joint configuration as well as fabrication and testing errors, are all evened out at maximum load due to the ductility available in the steel.

Tests were concluded when the specimens ceased to take any further load. As the specimens were loaded in tension, failure was distinct and easy to detect unlike compression specimens of Test Series A and C. Deformation from maximum load to complete failure (see S in Figure 4.20) was substantial and the coefficient of variation of 16.52 percent indicates that the results were consistent. This high extent of deformation gives adequate warning before failure in transmission towers employing these joints.

Elastic stiffness before commencement of slip is caused by the frictional load transfer and the mobilization of a greater area of effective cross section to resist the load. For this reason, elastic stiffness before commencement of slip is greater than the elastic stiffness after slip. In specimens set in bearing at assembly (see Table 4.5), corresponding stiffness could also be found as stiffness during frictional load transfer and stiffness during bolt bearing were observed distinctly in this test series. Values of elastic stiffness before commencement of slip show good consistency (see Table 4.5) as

indicated by the coefficient of variation of 7.71 percent due to symmetrical nature of the loading with bolts in double shear.

Values of elastic stiffness after slip (see Table 4.5) were consistent with a coefficient of variation of 12.49 percent. The considerable load range and deformation range covered during this stage make measurements accurate and thereby contribute to consistency.

Values of the ratio of elastic stiffness before commencement of slip to elastic stiffness after slip are greater than 2.95 due to the fact that the effective cross sectional area at the joint after slip is reduced. Results show consistency as indicated by the coefficient of variation of 12.94 percent (see Table 4.5).

Slip coefficient before joints go into bearing was found (see Table 4.5) using the formula (Fisher and Struik, 1974):

$$P_{slip} = k_s m \sum_{i=1}^n T_i$$

where  $P_{slip}$  = Slip load;

$k_s$  = Slip coefficient;

$m$  = Number of slip planes; and

$\sum_{i=1}^n T_i$  = Sum of clamping bolt tensions.

As stated in 4.2 (w), the clamping force used per bolt is 35.67 kN, the value used by Manitoba Hydro during erection of their transmission line towers.

Kennedy (1972) reported a value of 0.153 for galvanized joints and Brookhart et al. (1968) reported values ranging from 0.19 to 0.25. The observed values compare well with values reported in the literature, which were all bolted joints in double shear. The



values also show good consistency as shown by the coefficient of variation of 9.96 percent. Note that specimen BM1 was the first specimen to be tested. It was repeatedly mounted and dismounted from the end attachments of the testing machine to get it correctly in position and in the process either it has got jammed increasing the clamping force or the alignment of individual angles may have changed to give a higher than normal slip coefficient. Hence the slip coefficient value of specimen BM1 was not considered to be reliable. The joints set in bearing during assembly were excluded as there was no frictional load transfer in these joints.

Figures 4.25, 4.26, and 4.27 show load versus total joint deformation diagrams for joints with maximum construction clearance, normal construction clearance, and joints set in bearing at assembly respectively. Basic shapes were similar except for the following: -

- (i) Extent of slip was highest for joints with maximum construction clearance at assembly, none for joints set in bearing at assembly, and intermediate for joints with normal construction clearance at assembly;
- (ii) Slip consisted of either slip at approximately constant load, slip at a low stiffness or a combination of both. This can be attributed to fabrication difficulties that cause alignment problems when more than two members mate at the joint; and
- (iii) Portion of curve beyond maximum load had more kinks when more than one crack form either at the vertex of the gusset or a crack forms in one angle followed by a crack in the other angle.

Figures 4.28, 4.29, and 4.30 show typical variations of individual bolt deformation and total joint deformation with load for joints with maximum construction clearance, normal construction clearance, and joints set in bearing at assembly respectively. Individual values of deformation at bolts and total joint deformation are very similar and of the same order, with lower bolt (see Figure 4.28 to 4.30) most often recording the highest deformation by a very small margin. This indicates that the lower bolt is carrying a slightly higher load, but as the difference in deformation of bottom bolt and top bolt is very small, it can be assumed that the two bolts share the load approximately equally.

Total joint deformation is not equal to the sum of deformations of top and bottom bolt and instead total joint deformation is approximately equal to deformation of either bolt. This suggests that portions of gusset plate and angles between two bolts are either deforming equally or their deformations are negligible compared to bolt deformation. Inspection of extents of deformation undergone by the portions of gusset and angles between the two bolts show that the respective deformations are very small and negligible in comparison to bolt deformation values (see “s” below).

Figure 4.31 shows typical variations of deformations with load of the portions of gusset (G1) and angle (A1) between the two bolts in the joint. The deformations are similar and extent of deformation (about 0.3 mm) is negligibly small in comparison to bolt deformation values (about 15 mm).

Idealized curves are shown in Figures 4.32, 4.33, and 4.34 for joints with maximum construction clearance (3.18 mm), normal construction clearance (1.59 mm), and joints set in bearing at assembly. These are based on mean values observed during

experimental studies. Variation beyond maximum load up to failure was omitted as previous researchers (Kitipornchai et al., 1994; Frye et al., 1974; Jones et al., 1982; Lui et al., 1986; Chen et al., 1987; Goldberg et al., 1963; Romsted et al., 1970; Al-Bermani et al., 1992; Cox, 1972) have also not considered this region. Following effects were observed in the results for three categories of construction clearance at assembly: -

- (i) There were seven governing parameters, namely  $A$ ,  $\theta_1$ ,  $P$ ,  $Q$ ,  $B$ ,  $R$ , and  $C$  (see Figures 4.32 to 4.34), for the categories of maximum construction clearance, and normal construction clearance at assembly. The governing parameter  $P$  was not relevant for joints set in bearing at assembly and hence these joints had only six governing parameters (see Figure 4.34);
- (ii) Values of governing parameters  $A$ ,  $\theta_1$ ,  $Q$ ,  $B$ ,  $R$ , and  $C$  (see Figures 4.32 to 4.34) were the same for all the three categories;
- (iii) The governing parameter  $P$  varied for the categories of maximum construction clearance and normal construction clearance to give different values of slip. This parameter is not relevant for joints set in bearing at assembly as no slip occurred in them; and
- (iv) When more than two members frame into a joint and when the joint contains more than 1 bolt, slip of the joint is only a small part of the construction clearance at assembly.

Past researchers have used various theories to express quantitatively the behavior of joints (see 4.2 (cc)). Those methods were tried to develop mathematical expressions for load versus total joint deformation of the joint, and the best fitted curve was found to be: -

**Maximum construction clearance at assembly**

- (i)  $P = 211.38\delta$  for  $0.00 \leq \delta \leq 0.11$ ;
- (ii)  $P = 23.95$  for  $0.11 \leq \delta \leq 1.01$ ;
- (iii)  $P = 51.78(\delta - 1.01) + 23.95$  for  $1.01 \leq \delta \leq 3.10$ ; and
- (iv)  $P = 0.96(\delta - 3.10)^3 - 12.25(\delta - 3.10)^2 + 51.87(\delta - 3.10) + 132.17$   
for  $3.10 \leq \delta \leq 7.09$ ;

where  $P$  = Load on the joint in kN; and

$\delta$  = Deformation of the joint in mm;

**Normal construction clearance at assembly**

- (i)  $P = 211.38\delta$  for  $0.00 \leq \delta \leq 0.11$ ;
- (ii)  $P = 23.95$  for  $0.11 \leq \delta \leq 0.33$ ;
- (iii)  $P = 51.78(\delta - 0.33) + 23.95$  for  $0.33 \leq \delta \leq 2.42$ ; and
- (iv)  $P = 0.96(\delta - 2.42)^3 - 12.25(\delta - 2.42)^2 + 51.87(\delta - 2.42) + 132.17$   
for  $2.42 \leq \delta \leq 6.41$ ;

where  $P$  = Load on the joint in kN; and

$\delta$  = Deformation of the joint in mm;

**Set in bearing at assembly**

- (i)  $P = 211.38\delta$  for  $0.00 \leq \delta \leq 0.11$ ;
- (ii)  $P = 51.78(\delta - 1.01) + 23.95$  for  $0.11 \leq \delta \leq 2.20$ ; and
- (iii)  $P = 0.96(\delta - 2.20)^3 - 12.25(\delta - 2.20)^2 + 51.87(\delta - 2.20) + 132.17$   
for  $2.20 \leq \delta \leq 6.19$ ;

where  $P$  = Load on the joint in kN; and

$\delta$  = Deformation of the joint in mm.

Feasibility of interpolation or extrapolation of the load-deformation relationship for similar joints with less or more number of bolts was considered. Results of Test Series C (see 4.4) indicate that the load-deformation diagrams of joints can be interpolated or extrapolated for joints similar in configuration but differing in number of bolts. Hence interpolation or extrapolation of load-deformation relationship for similar joint configurations can be recommended and further research is necessary to obtain regression equations of the governing parameters. This requires further testing of specimens with number of bolts increased or decreased in this type of joint.

#### **4.4 ANALYSIS OF RESULTS OF TEST SERIES C**

In this test series bolts were in single shear and in specimens where multiple bolts were used, bolts were on one longitudinal line.

Some typical load versus deformation diagrams and other useful data are shown in Figures 4.35 to 4.62. Test results are summarized in Tables 4.7 to 4.10.

The noteworthy observations made from the analysis of the results are presented below.

In this type of lap joint with angles back to back, even if the loading is done to simulate pure shear in the bolt or bolts, bending moments develop in the angle sections at the bolted joint, and the joint rotates from vertical at higher loadings. This rotation causes the shear load on the bolt to reduce (see Figure 4.35) and the tensile load to increase. Similar effect was reported by Fisher et al. (1974) for plate lap joints. The amount of rotation increases when specimen ends are pinned rather than fixed.

When specimen C3M1 was tested, the rotation was so excessive that angle began to buckle and it was evident that for 3-bolt and 4-bolt joints unless early buckling is not prevented, bolts will not be critically loaded in shear. Hence for subsequent tests on 3-bolt and 4-bolt joints, ends were kept fixed except for a small initial movement up to a maximum of 4.45 degrees to take up any imperfections of the angle ends.

The specimen C1M1 was tested using pinned end support conditions first, but was stopped prematurely due to a mistake in identifying onset of yielding as onset of failure. Later it was re-tested with fixed end support conditions. Although mode of failure changed from angle under plastic bending to bolt shear, the maximum load did not change significantly. Further, other important properties such as load at slip, load at onset of plasticity, extent of slip, elastic stiffness before slip, elastic stiffness after slip, and slip coefficient did not change significantly (see C1M1 of Tables 4.7 to 4.10). This demonstrated that the change of support conditions did not alter the maximum load or other important joint properties significantly, although bolt was more severely loaded in shear.

A typical load versus total joint deformation diagram is shown in Figure 4.36. The main differences between diagrams obtained for each specimen were observed to be as follows: -

- (i) Length of slip "P" (see Figure 4.36) was highest for maximum construction clearance, lowest and virtually non-existent for bearing, and an intermediate value for normal construction clearance at assembly; and

- (ii) Three-bolt and four-bolt joints developed large deformations after reaching the maximum load indicating a tendency for the bolts to fail by shear, rather than by angle buckling.

A typical load versus total joint deformation diagram (see Figure 4.36) was observed to have the following distinct segments: -

- (i) A segment of elastic frictional load transfer (ab);
- (ii) A segment of slip at approximately constant load (bc);
- (iii) A segment of elastic load transfer by bolt bearing (cd);
- (iv) A segment of non-linear load transfer extending up to maximum load, where angle sections undergo plastic rotation thus rotating the bolted joint (de); and
- (v) A segment commencing from maximum load and leading up to failure either with a flatter curve (ef) showing bolt under shear deformation, or a steeper curve (eg) showing angle under buckling deformation. These findings conform with the results reported by previous researchers (Fisher et al., 1974).

Two specimens, namely C1M1 and C1M2, showed (see Figure 4.37) a marked variation from the typical load versus total joint deformation diagram by showing a distinct kink in the form of a vertical disturbance at the point, where the specimen, which is still straight, begins to develop rotation visible even to the naked eye. A similar variation, but less pronounced, was observed in only one other specimen, namely C1B1 (see Figure 4.46). C1B1 was tested at a loading rate of 0.004 mm/sec while C1M1 and C1M2 were tested at a loading rate of 0.002 mm/sec. This effect is attributed to: (i) The onset of yielding of the angle section and magnification of the discontinuous yielding process due to generally low loading rates used in the tests; and (ii) Specimen abruptly

undergoing rotation, due to some geometric imperfections in the specimen, to change its deformed shape from a straight profile to a buckling profile, rather than undergoing the more common gradual change from straight profile to a buckling profile. Note that in all other tests, a loading rate of 0.004 mm/sec was used, which is lower than the rate of 0.106 to 0.212 mm/sec recommended by ASTM F606 (1993). A very low rate was considered necessary to observe the slip in the joint accurately.

Following modes of failures were observed in the Test Series C:

- (i) Specimens C1M1, C1M2, C1M3, C1N1, C1N2, C1N3, C1B1, C1B2, C1B3, C2M1 (see Figure 4.38), C2M2, C2M3, C2N1, C2N2, C2N3, C2B1, C2B2, C2B3, and C3M1 failed with angle section reaching plastic bending failure. Note that in the case of C1M1, test was terminated, by mistake, just after angle section began to develop large rotational deformations due to plastic bending of the angle;
- (ii) Specimens C3M2 (see Figure 4.39), C3M3, C3N1, C3N2, C3N3, C3B1, C3B2, C3B3, C4M1 (see Figure 4.40), C4M2, C4M3, C4N1, C4N2, C4N3, C4B1, C4B2, and C4B3 failed with bolts under shear failure along with angle sections reaching some stage of plasticity; and
- (iii) Specimen C1M1 when re-tested under fixed end support conditions failed with the bolt shearing completely apart (see Figure 4.41).

Load at commencement of slip (see A in Figure 4.36) is defined as the load at which significant slip takes place at approximately constant load. Values of load per bolt at commencement of slip were similar (see Table 4.7) for single-bolt, 2-bolt, 3-bolt, and 4-bolt assemblies with maximum and normal construction clearance, as shown by



their mean values ranging from 9.29 kN to 11.74 kN. Bolted joints set in bearing during assembly, showed no slip. The coefficient of variation values ranging from 6.87 percent to 21.89 percent, also show the consistency of values of load at commencement of slip. Also values of load at commencement of slip are approximately directly proportional to the number of bolts in the assembly, but do not depend on maximum or normal construction clearance at assembly.

Load at onset of plasticity (see B in Figure 4.36) is defined as the load at which elastic response of the joint changes to non-linear behavior due to development of plastic bending in the angle. The mean of load per bolt of 2-bolt joints (48.75 kN) is marginally less than that of 3-bolt joints (50.95 kN) possibly due to change in support end conditions. Values of load per bolt at onset of plasticity decrease erratically (see Table 4.7) with increasing the number of bolts, while coefficient of variation values ranging from 3.33 percent to 11.52 percent show the consistency of the results. Values of total load at onset of plasticity increase with number of bolts in the assembly but not in direct proportion, and are independent of construction clearance at assembly. These values of total load also show reasonable consistency with the coefficient of variation ranging from 3.33 percent to 11.52 percent.

Maximum load (see C in Figure 4.36) is defined as the highest load reached by the bolted joint during the test. Values of load per bolt at maximum load decrease (see Table 4.7) with increasing number of bolts as loads on bolts are not distributed evenly. However, values of load per bolt at maximum load are independent of construction clearance condition at assembly, while coefficient of variation values ranging from 2.40 percent to 11.68 percent show the consistency of the results. Maximum load results also

show that maximum load cannot be increased by increasing the number of bolts beyond 3 bolts as angle becomes critically stressed. Further, as demonstrated by specimen C4M1, joint loaded instantaneously showed a maximum load not very different indicating that the loading rate may not significantly affect the maximum load of a specimen.

Extent of slip (see P in Figure 4.36) is defined as the slip that takes place approximately at constant load, which is normally a very low load value. No slip was observed (see Table 4.8) for joints set in bearing during assembly. Those joints with maximum construction clearance gave the highest extent of slip values, while those joints with normal construction clearance gave intermediate extent of slip values. Extent of slip changes irregularly with number of bolts and appears to be independent of the number of bolts, but dependent on construction clearance at assembly.

Extent of slip observed during tests, irrespective of number of bolts in the joint, was always less than the maximum possible slip in a joint. In the case of joints with maximum construction clearance, the mean value of extent of slip was 2.21 mm while maximum possible slip was 3.18 mm. In the case of joints with normal construction clearance, the respective values were 0.85 and 1.59 mm. This can be attributed to normal tolerances likely in the shop production process and the fabrication process.

Deformation between end of slip and onset of plasticity (see Q in Figure 4.36) varies elastically with the load, and most bolted joints in service function in this range. It is independent of construction clearance at assembly (see Table 4.8) and number of bolts in the joint. Coefficient of variation ranged from 15.14 percent to 22.52 percent indicating that it is somewhat variable due to inconsistent nature of the onset of plasticity in the joint.

Deformation between onset of plasticity and maximum load (see R in Figure 4.36) varies non-linearly with load. It is independent of construction clearance at assembly (see Table 4.8) as during this stage all bolts are in bearing irrespective of the starting condition. Mean values indicate that it reduces with number of bolts (see Table 4.8). Coefficient of variation values range from 15.82 percent to 23.84 percent indicating that it is somewhat variable due to inconsistent nature of the onset of plasticity in the joint.

Testing was concluded when either the specimen takes no more load or when the load reaches 10 percent below the maximum load. In Test Series C specimens, because of buckling, specimens did not completely refuse to take load, and instead load decreased gradually with increasing deformation (see “eg” and “ef” in Figure 4.36). Hence testing was concluded before complete failure. Deformation from maximum load to 10 percent below maximum load changes with failure mode. These values were highest (in the 4-bolt specimens) when bolt shear failure was in progress (see Table 4.8), and lowest (in the 2-bolt specimens) when angle section was under elasto-plastic buckling.

Elastic stiffness of the joint before commencement of slip was difficult to find for joints with less bolts because slip load was very low. In general, elastic stiffness of the joint before commencement of slip (see Table 4.9) was greater than the elastic stiffness after slip. Ratio of elastic stiffness before commencement of slip to elastic stiffness after slip increased with number of bolts up to 3 bolts as overlapped length of angles increased. Slight drop in the ratio for 4-bolt joints can be attributed to higher variability encountered in these tests as shown by a coefficient of variation of 29.43 percent.

Elastic stiffness during unloading after failure was observed (see Table 4.9) only for the specimens tested later. This was not found to be a useful parameter because elastic stiffness during unloading after failure will depend on any reduction in area, any change of shape from straight to curved profile, or any change in length that has occurred during the failure process of the specimen.

Elastic stiffness of the joint before commencement of slip increased with number of bolts, but not in direct proportion. This can be attributed to increased effective area due to increased overlap length. Coefficient of variation ranged from 17.08 percent to 24.56 percent showing that results are reasonably consistent. Further, these stiffness values are not dependent on conditions of construction clearance.

Values of elastic stiffness after slip (see Table 4.9) were the most consistent of elastic stiffness measurements where coefficient of variation ranged from 7.59 percent to 26.54 percent. Further, these stiffness values were independent of the condition of construction clearance at assembly.

Slip coefficient before joints go into bearing was found (see Table 4.10) using the formula (Fisher and Struik, 1974):

$$P_{slip} = k_s m \sum_{i=1}^n T_i$$

where  $P_{slip}$  = Slip load;  
 $k_s$  = Slip coefficient;  
 $m$  = Number of slip planes; and  
 $\sum_{i=1}^n T_i$  = Sum of clamping bolt tensions.

As stated in 4.2 (w), the clamping force used per bolt is 35.67 kN, the value used by Manitoba Hydro during erection of their transmission line towers.

Kennedy (1972) reported a value of 0.153 for galvanized joints and Brookhart et al. (1968) reported values ranging from 0.19 to 0.25. The observed values were little higher due to bigger washers used for the galvanized angle joints. The values show good consistency as shown by the coefficient of variation ranging from 6.87 percent to 21.89 percent. Fisher et al. (1974) have reported a coefficient of variation of 38.1 percent for joints with “as received” galvanized surfaces and results of Test Series C show lesser variability. The joints in bearing during assembly were excluded as there was no frictional load transfer in those joints.

Figure 4.42 shows load versus total joint deformation diagrams for single bolted joints with normal construction clearance (1.59 mm) at assembly. Single bolted joints with maximum construction clearance at assembly showed similar behavior except that slip was more. Single bolted joints set in bearing at assembly showed similar behavior except that they had no slip.

Figure 4.43 shows typical load versus bolt deformation diagrams for a joint with two bolts and normal construction clearance (1.59 mm) at assembly. In all these joints, deformation of top and bottom bolts were similar up to the end of slip, but thereafter deformation of top bolt was more than that of bottom bolt and the total joint deformation was in between those values. This meant that the bottom bolt showed a higher stiffness and hence carried a larger portion of the load. Bottom bolt reached yielding and ultimate load first followed by the top bolt. This behavior can be attributed to the higher rotation capacity of the lower angle since the lower pinned joint allowed a greater rotation than

the top joint, which only allowed the standard rotation of a loading platen of a testing machine. It should be noted that the bottom pin was replaced in tests after C3M1. Behavior of joints with maximum construction clearance at assembly and joints set in bearing at assembly resembled the former joints in all other respects except that the extent of slip was different.

Figure 4.44 shows typical load versus bolt deformation diagrams for a joint with three bolts and normal construction clearance (1.59 mm) at assembly. Extent of bolt deformation experienced by the three bolts differed after the end of slip with the total joint deformation of the joint taking a value in between those of individual bolts. In all the joints, middle bolt showed higher bolt deformation values indicating a lower stiffness. Hence greater load shares were taken by the top and bottom bolts while the middle bolt took the least load. This load sharing pattern is in conformity with the findings of Fisher et al. (1974). The differences between behavior of bolt assemblies with maximum construction clearance, normal construction clearance and those set in bearing at assembly were only in the extent of slip with the rest of behavior being similar.

Figure 4.45 shows typical load versus bolt deformation diagrams for a joint with four bolts and normal construction clearance (1.59 mm) at assembly. Extent of bolt deformations experienced by the four bolts up to the end of slip formed into a narrow band but widened later after the end of slip. In all the joints total joint deformation took an intermediate value in between the bolt deformation values of individual bolts. Specimen C4M1, which was accidentally loaded instantaneously to failure, was not considered in this analysis. In all the joints least bolt deformation was observed at middle top bolt, next higher bolt deformation was observed at bottom bolt, next higher bolt

deformation was observed at middle bottom bolt, and the highest bolt deformation was observed at top bolt. This meant that share of load taken by each bolt increased from middle top bolt (highest load), bottom bolt, middle bottom bolt, and top bolt (lowest load). This pattern of load transfer is inconsistent with the findings based on deformation of portions of angle between bolts (see 4.4 (z)) and the findings of Fisher et al. (1974). This can be attributed to the fact that bolt deformations cannot be strictly used to measure load transferred by bolts because bolt deformations measured in this study include bolt hole deformation of the angles near the bolt in addition to the actual bolt deformation. In situations where bolt holes undergo significant deformations only near failure, bolt deformations can be used to measure the load transferred by the bolt.

The differences between bolt assemblies with maximum construction clearance, normal construction clearance and those set in bearing at assembly were only in the extent of slip, with the rest of behavior being similar.

Figure 4.37, 4.42, and 4.46 show the variation of load versus individual bolt deformation of single bolted joints with maximum construction clearance, normal construction clearance, and those set in bearing at assembly and illustrate that their main difference is in their response during slip with the extent of slip being a function of construction clearance at assembly. Extent of slip was greatest for joints with maximum construction clearance, least or non-existent for joints set in bearing at assembly, and an intermediate value for joints with normal construction clearance at assembly. The above effect is illustrated further in: (i) Figures 4.43, 4.47, and 4.48 for joints with two bolts; (ii) Figures 4.44, 4.49, and 4.50 for joints with three bolts; and (iii) Figures 4.45, 4.51, and 4.52 for joints with four bolts.

Figure 4.53 shows the typical variation of load and deformation between bolt holes in the angle sections of joints with two bolts. These variations are very similar showing that the joint was loaded uniformly. Zig-zag nature of the diagrams are due to the magnified scale used to express deformations.

Figure 4.54 shows the typical variation of load and deformation between bolt holes in the angle sections of joints with three bolts. Note that deformation A2B could not be measured due to a defective transducer. A1T and A2T of the top angle show similar values of slip up to 75 kN ( $3/8^{\text{th}}$  of the maximum load), thereafter diverges and due to redistribution of stresses after yielding reach similar deformations near maximum load. Similarity of deformations of A1T and A2T indicates that during earlier stages and during latter stages, middle bolt does not transfer substantial loads. A1B shows clearly the change in deformation pattern of the specimen by reversal of deformation pattern from compression mode to compression and bending mode after yielding of the angle. Further, the high stiffness of A1B in comparison to A1T shows that top bolt transfers a large component of the total load. These findings on load transfer conform with work reported by Fisher et al. (1974).

Figure 4.55 shows the typical variation of load and deformation between bolt holes in the angle section of joints with four bolts. Note that deformation A1B could not be measured due to a defective transducer. Similarity of deformations of A1T and A2T indicates that the middle top bolt does not transfer a substantial component of the total load. Further, the similarity of deformation of A2B and A3B indicates that the middle bottom bolt does not transfer a substantial portion of the total load. Similarity in stiffness



of A3T to those of A1T and A2T confirms, further, that the middle bottom bolt is carrying a small portion of the load.

As stiffness of A1B is not available, extent of load transfer by top bolt cannot be directly identified, but considerable stiffness of A2B and A3B and the fact that middle bolts do not transfer heavy loads indicate that the top bolt carries the highest load. These findings as regards load transfer are in conformity with the results reported by Fisher et al. (1974).

The diagrams also show the occurrence of slip at about 40 kN, and plastic bending of the angle near failure by sharp variations in the deformation pattern at higher loads.

Idealized curves are shown in Figure 4.56, 4.57, and 4.58 for joints with maximum construction clearance (3.18 mm), normal construction clearance (1.59 mm), and those set in bearing at assembly. These are based on mean values observed during experimental studies. Variation beyond maximum load up to failure was omitted as previous researchers have also not considered this region (Kitipornchai et al., 1994; Frye et al., 1974; Jones et al., 1982; Lui et al., 1986; Chen et al., 1987; Goldberg et al., 1963; Romsted et al., 1970; Al-Bermani et al., 1992; Cox, 1972). Following effects were observed in the results for three categories of construction clearance at assembly: -

- (i) Governing parameters ( $A$  and  $\theta_1$  in Figures 4.56 to 4.58) of the region of frictional load transfer, varied with number of bolts, but for a given number of bolts remained constant for all categories of construction clearance;
- (ii) There were seven governing parameters, namely  $A$ ,  $\theta_1$ ,  $P$ ,  $Q$ ,  $B$ ,  $R$ , and  $C$  (see Figures 4.56 to 4.57), for the categories of maximum construction clearance,

and normal construction clearance at assembly. The governing parameter P was not relevant for joints set in bearing at assembly and hence they had only six governing parameters (see Figure 4.58);

- (iii) Values of governing parameters A,  $\theta_1$ , Q, B, R, and C (see Figures 4.56 to 4.58) varied with number of bolts, but for a given number of bolts remained constant for all the three categories of construction clearance;
- (iv) The governing parameter P varied for the categories of maximum construction clearance and normal construction clearance to give different values of slip. This parameter is not relevant for joints set in bearing at assembly as no slip occurred in them;
- (v) Slip observed for maximum construction clearance at assembly and normal construction clearance at assembly does not depend on number of bolts. However, in each case maximum possible slip (3.18 mm and 1.59 mm respectively) never occurred in a joint. Only 69.5 percent and 53.5 percent of maximum possible slip occurred in joints with maximum construction clearance and normal construction clearance respectively due to shop production and assembly deviations; and
- (vi) Governing parameters A,  $\theta_1$ , Q, B, R, and C varied approximately linearly with the number of bolts (see Figure 4.59). The respective regression equations are also given in Figure 4.59.

Past researchers have used various theories to express quantitatively the behavior of joints (see 4.2 (cc)). Those methods were tried to develop mathematical expressions

for load versus total joint deformation of the joint, and the best fitted curve was found to be: -

### **Maximum construction clearance at assembly**

#### **1. Single bolted joint**

- (i)  $P = 27.51\delta$  for  $0.00 \leq \delta \leq 0.34$  ;
- (ii)  $P = 9.29$  for  $0.34 \leq \delta \leq 2.55$  ;
- (iii)  $P = 20.34(\delta - 2.55) + 9.29$  for  $2.55 \leq \delta \leq 5.29$  ; and
- (iv)  $P = 0.17(\delta - 5.29)^3 - 3.23(\delta - 5.29)^2 + 20.39(\delta - 5.29) + 65.03$   
for  $5.29 \leq \delta \leq 11.33$  ;

where  $P$  = Load on the joint in kN; and

$\delta$  = Deformation of the joint in mm;

#### **2. Two-bolt joint**

- (i)  $P = 84.81\delta$  for  $0.00 \leq \delta \leq 0.24$  ;
- (ii)  $P = 20.14$  for  $0.24 \leq \delta \leq 2.45$  ;
- (iii)  $P = 44.72(\delta - 2.45) + 20.14$  for  $2.45 \leq \delta \leq 4.18$  ; and
- (iv)  $P = -0.38(\delta - 4.18)^3 - 7.35(\delta - 4.18)^2 + 44.82(\delta - 4.18) + 97.51$   
for  $4.18 \leq \delta \leq 6.73$  ;

where  $P$  = Load on the joint in kN; and

$\delta$  = Deformation of the joint in mm;

#### **3. Three-bolt joint**

- (i)  $P = 113.92\delta$  for  $0.00 \leq \delta \leq 0.26$  ;
- (ii)  $P = 29.28$  for  $0.26 \leq \delta \leq 2.47$  ;
- (iii)  $P = 51.49(\delta - 2.47) + 29.28$  for  $2.47 \leq \delta \leq 4.87$  ; and

$$(iv) \quad P = 0.88(\delta - 4.87)^3 - 14.66(\delta - 4.87)^2 + 51.42(\delta - 4.87) + 152.85$$

for  $4.87 \leq \delta \leq 7.05$ ;

where  $P$  = Load on the joint in kN; and

$\delta$  = Deformation of the joint in mm;

#### 4. Four-bolt joint

$$(i) \quad P = 138.95\delta \quad \text{for } 0.00 \leq \delta \leq 0.34 ;$$

$$(ii) \quad P = 46.95 \quad \text{for } 0.34 \leq \delta \leq 2.55 ;$$

$$(iii) \quad P = 65.54(\delta - 2.55) + 46.95 \quad \text{for } 2.55 \leq \delta \leq 4.40 ; \text{ and}$$

$$(iv) \quad P = -1.70(\delta - 4.40)^3 - 25.28(\delta - 4.40)^2 + 65.53(\delta - 4.40) + 168.21$$

for  $4.40 \leq \delta \leq 5.56$ ;

where  $P$  = Load on the joint in kN; and

$\delta$  = Deformation of the joint in mm;

### Normal construction clearance at assembly

#### 1. Single bolted joint

$$(i) \quad P = 27.51\delta \quad \text{for } 0.00 \leq \delta \leq 0.34 ;$$

$$(ii) \quad P = 9.29 \quad \text{for } 0.34 \leq \delta \leq 1.19 ;$$

$$(iii) \quad P = 20.34(\delta - 1.19) + 9.29 \quad \text{for } 1.19 \leq \delta \leq 3.93 ; \text{ and}$$

$$(iv) \quad P = 0.17(\delta - 3.93)^3 - 3.23(\delta - 3.93)^2 + 20.39(\delta - 3.93) + 65.03$$

for  $3.93 \leq \delta \leq 9.97$ ;

where  $P$  = Load on the joint in kN; and

$\delta$  = Deformation of the joint in mm;

#### 2. Two-bolt joint

$$(i) \quad P = 84.81\delta \quad \text{for } 0.00 \leq \delta \leq 0.24 ;$$

- (ii)  $P = 20.14$  for  $0.24 \leq \delta \leq 1.09$  ;
- (iii)  $P = 44.72(\delta - 1.09) + 20.14$  for  $1.09 \leq \delta \leq 2.82$  ; and
- (iv)  $P = -0.38(\delta - 2.82)^3 - 7.35(\delta - 2.82)^2 + 44.82(\delta - 2.82) + 97.51$   
for  $2.82 \leq \delta \leq 5.37$  ;

where  $P$  = Load on the joint in kN; and

$\delta$  = Deformation of the joint in mm;

### 3. Three-bolt joint

- (i)  $P = 113.92\delta$  for  $0.00 \leq \delta \leq 0.26$  ;
- (ii)  $P = 29.28$  for  $0.26 \leq \delta \leq 1.11$  ;
- (iii)  $P = 51.49(\delta - 1.11) + 29.28$  for  $1.11 \leq \delta \leq 3.51$  ; and
- (iv)  $P = 0.88(\delta - 3.51)^3 - 14.66(\delta - 3.51)^2 + 51.42(\delta - 3.51) + 152.85$   
for  $3.51 \leq \delta \leq 5.69$  ;

where  $P$  = Load on the joint in kN; and

$\delta$  = Deformation of the joint in mm;

### 4. Four-bolt joint

- (i)  $P = 138.95\delta$  for  $0.00 \leq \delta \leq 0.34$  ;
- (ii)  $P = 46.95$  for  $0.34 \leq \delta \leq 1.19$  ;
- (iii)  $P = 65.54(\delta - 1.19) + 46.95$  for  $1.19 \leq \delta \leq 3.04$  ; and
- (iv)  $P = -1.70(\delta - 3.04)^3 - 25.28(\delta - 3.04)^2 + 65.53(\delta - 3.04) + 168.21$   
for  $3.04 \leq \delta \leq 4.20$  ;

where  $P$  = Load on the joint in kN; and

$\delta$  = Deformation of the joint in mm;

## **Set in bearing at assembly**

### **1. Single bolted joint**

- (i)  $P = 27.51\delta$  for  $0.00 \leq \delta \leq 0.34$  ;
- (ii)  $P = 20.34(\delta - 0.34) + 9.29$  for  $0.34 \leq \delta \leq 3.08$  ; and
- (iii)  $P = 0.17(\delta - 3.08)^3 - 3.23(\delta - 3.08)^2 + 20.39(\delta - 3.08) + 65.03$   
for  $3.08 \leq \delta \leq 9.12$  ;

where  $P$  = Load on the joint in kN; and

$\delta$  = Deformation of the joint in mm;

### **2. Two-bolt joint**

- (i)  $P = 84.81\delta$  for  $0.00 \leq \delta \leq 0.24$  ;
- (ii)  $P = 44.72(\delta - 0.24) + 20.14$  for  $0.24 \leq \delta \leq 1.97$  ; and
- (iii)  $P = -0.38(\delta - 1.97)^3 - 7.35(\delta - 1.97)^2 + 44.82(\delta - 1.97) + 97.51$   
for  $1.97 \leq \delta \leq 4.52$  ;

where  $P$  = Load on the joint in kN; and

$\delta$  = Deformation of the joint in mm;

### **3. Three-bolt joint**

- (i)  $P = 113.92\delta$  for  $0.00 \leq \delta \leq 0.26$  ;
- (ii)  $P = 51.49(\delta - 0.26) + 29.28$  for  $0.26 \leq \delta \leq 2.66$  ; and
- (iii)  $P = 0.88(\delta - 2.66)^3 - 14.66(\delta - 2.66)^2 + 51.42(\delta - 2.66) + 152.85$   
for  $2.66 \leq \delta \leq 4.84$  ;

where  $P$  = Load on the joint in kN; and

$\delta$  = Deformation of the joint in mm;

#### 4. Four-bolt joint

- (i)  $P = 138.95\delta$  for  $0.00 \leq \delta \leq 0.34$  ;
- (ii)  $P = 65.54(\delta - 0.34) + 46.95$  for  $0.34 \leq \delta \leq 2.19$  ; and
- (iii)  $P = -1.70(\delta - 2.19)^3 - 25.28(\delta - 2.19)^2 + 65.53(\delta - 2.19) + 168.21$   
for  $2.19 \leq \delta \leq 3.35$  ;

where  $P$  = Load on the joint in kN; and

$\delta$  = Deformation of the joint in mm.

Using the theory of Fisher and Rumpf (1965) and considering load versus deformation diagram of: -

- (i) Bolt as the mean of bolt deformation from single bolted joint tests; and
- (ii) Portion of angle between bolt holes as the mean of angle deformations from joints with two bolts, an analysis was carried out. It was found that the deformation of bolt can be expressed as a function of bolt load as follows: -

##### Maximum construction clearance:

$$\delta_b = 3 \times 10^{-5} R_b^3 - 0.0040 R_b^2 + 0.2251 R_b - 0.1588$$

##### Normal construction clearance:

$$\delta_b = 2 \times 10^{-5} R_b^3 - 0.0031 R_b^2 + 0.1845 R_b - 0.4122$$

##### Set in bearing:

$$\delta_b = 1 \times 10^{-5} R_b^3 - 0.0012 R_b^2 + 0.0077 R_b - 0.1583$$

where  $R_b$  = Load resistance by the bolt in kN; and

$\delta_b$  = Deformation of the bolt in mm.

It was also found that the deformation of the portion of the angle between two bolt holes can be expressed as a function of load carried by the portion of the angle between two bolt holes as follows: -

$$\delta_h = 3 \times 10^{-7} R_h^3 - 5 \times 10^{-5} R_h^2 + 0.0046 R_h + 0.0119$$

where  $R_h$  = Load carried by the portion of the angle between bolt holes in kN; and

$\delta_h$  = Deformation of the portion of the angle between bolt holes in mm.

Results of the analysis are shown in Figure 4.61 and 4.62, and the following observations are made from the results: -

- (i) Proportions of load carried by each bolt fall into a general pattern in which outer bolts carry highest loads while middle bolts carry lower loads, and the pattern is in agreement with the findings of previous researchers (Fisher et al., 1965; Fisher et al., 1974);
- (ii) Proportions of load carried by each bolt become more divergent near ultimate load and this effect is also in agreement with the findings of previous researchers (Fisher et al., 1965; Fisher et al., 1974);
- (iii) Percentage loads carried by intermediate and end bolts become more uniform for joints with maximum construction clearance and most divergent for joints set in bearing for three-bolt and four-bolt joints; and
- (iv) Percentage loads, carried by end bolts of the three-bolt joint with maximum construction clearance at ultimate load, are slightly lower than expected probably because of higher percentage of error in satisfying the equilibrium equation.



Variations of shear strength per bolt with number of bolts as well as length of the joint are shown in Figure 4.60, and the relationships are approximately linear. The reduction in shear strength is caused by unequal load distribution among bolts with outer bolts carrying highest loads while middle bolts carrying progressively reduced loads.

Feasibility of interpolation or extrapolation of the load-deformation relationship for joints similar in configuration but differing in number of bolts was considered. Results of Test Series C indicate that the governing parameters vary linearly (see Figure 4.59) with the number of bolts, and the value of a governing parameter for the required number of bolts can be obtained from the regression equations (see Figure 4.59). Based on these results, extrapolation of load-deformation relationship for joints of similar configuration but differing in number of bolts can be recommended as a tentative measure, but further research should be conducted to confirm this recommendation.

#### **4.5 COMPARISON OF RESULTS IN TEST SERIES A, B, AND C**

The Test Series A dealt with a critical compression joint in a transmission line tower, while Test Series B dealt with a critical tension joint in a transmission line tower. In contrast, Test Series C dealt with a simple and economical joint in a transmission line tower where two members are joined directly without additional components such as gusset plates or splice angles.

A comparison of the results of the Test Series A, B, and C was carried out and the findings are shown below.

Table 4.11 shows the load values at various important stages of the loading process for each of the Test Series A, B, and C. Results show that: -

- (i) In Test Series B and C, there was no significant difference between the load at the commencement of slip and the load at the end of slip, because slip occurred at approximately constant load. However, in Test Series A, slip occurred at a varying load, but at a very low stiffness;
- (ii) In Test Series B and C, there was no significant difference in load at the end of slip for joints with maximum construction clearance and joints with normal construction clearance. In contrast, Test Series A had different values for the above two construction clearances respectively. This was because in Test Series A, although slip occurred at an approximately constant stiffness, load at the end of slip was higher for maximum construction clearance, which had a greater extent of slip;
- (iii) Load at commencement of slip of Test Series A is similar to that of a four-bolt joint of Test Series C. This can be attributed to the number of bolts transferring the load being the same in each case. Similarly as the number of bolts is the same, load at commencement of slip of Test Series B was similar to that of a two-bolt joint of Test Series C;
- (iv) As regards load at the end of slip, results of Test Series B compare well with the results of two-bolt joints of Test Series C, as the number of bolts is the same. However, results of Test Series A are very different from those of Test Series B and C;
- (v) Values of load at onset of plasticity of the three test series are significantly different; and

- (vi) As regards maximum load, Test Series A with four bolts developed a higher load than a four-bolt joint of Test Series C, because of the better load distribution through both legs of the angle in the former in comparison to the load distribution through only one leg of the angle in the latter. The maximum load of Test Series B with two bolts compares well with that of four-bolt joint in Test Series C. This can be attributed to the fact that two bolts in double shear is equivalent to four bolts in single shear as regards shear capacity.

Table 4.12 shows slip and deformation values at various important stages of the loading process for each of the Test Series A, B, and C. Results show that: -

- (i) Deformations under frictional load transfer in Test Series A and C were comparable because both had all the bolts in single shear. Corresponding deformation was less in Test Series B, because bolts were in double shear where more interfaces are active in frictional load transfer;
- (ii) Slip values in three test series were different from each other with the Test Series B showing the least values. This can be attributed to greater influence of shop production and fabrication errors in joints where more than two members are connected. It should be noted that slip values in Test Series A should be halved for comparison with others because in reality each joint in this test series consisted of two separate joints, namely top angle-splice angle joint and splice angle-bottom angle joint;
- (iii) Values of deformation during load transfer by bolt bearing were comparable in Test Series B and C. This can be attributed to angles maintaining spacing

between bolt holes unchanged because they remain elastic during this stage.

These values were not applicable to Test Series A;

- (iv) Values of deformation between onset of plasticity and maximum load in the three test series were different from each other with the Test Series A showing the least value. This can be attributed to the delay in the onset of plasticity in Test Series A due to improvement of load transfer after direct contact is made between top and bottom angles; and
- (v) Values of deformation reached at maximum load were similar on the three test series because virtually all the ductility of the bolt material was harnessed before failure in each test series irrespective of the failure mode.

Table 4.13 shows elastic stiffness values at various important stages of the loading process for each of the Test Series A, B, and C. Results show that values of elastic stiffness before slip were highest in Test Series A and lowest in Test Series C. This can be attributed to increased contact area providing better composite action of the connected members in the vicinity of the joint.

Table 4.14 shows the load at commencement of slip as a ratio of load at other important loading stages of the loading process for each of the Test Series A, B, and C. Results show that: -

- (i) the value of the ratio load at slip to load at the end of slip was constant at 1.00 for Test Series B and C indicating that slip occurred at a constant load. The values for Test Series A indicate that for joint with maximum construction clearance, the load increase during slip is more than that for joints with normal construction clearance; and

- (ii) the ratio of load at slip to load at onset of plasticity and the ratio of load at slip to maximum load were comparable for the three test series indicating that the region of ductile response is similar for all the tested joints.

Table 4.15 shows the slip as a ratio of deformation at other important stages of the loading process for each of the Test Series A, B, and C. Results show that: -

- (i) the values of the ratio of slip to deformation reached at maximum load range from 0.03 to 0.44 for all the three test series. The above ratios in the work reported by Fisher et al. (1974) and Shoukry et al. (1970) for friction type bolted joints are 0.09 and 0.06 respectively. This comparison demonstrates that slip when considered in relation to deformation at maximum load is considerable in bearing type joints. Hence joint slip of bearing type joints should be separately accounted for in analytical work; and
- (ii) the values of the ratio of slip to deformation reached at onset of plasticity range from 0.09 to 0.48 for all the three test series. The above ratios in the work reported by Fisher et al. (1974) and Shoukry et al. (1970) for friction type bolted joints are 0.50 and 0.18 respectively. This comparison demonstrates that slip when considered in relation to deformation at onset of plasticity is similar in both bearing and friction type joints. As deformation at maximum load is far more important than deformation at onset of plasticity, it can be concluded that joint slip of bearing type joints cannot be ignored in a manner similar to that of friction type joints. Hence joint slip should be separately accounted for in analytical methods.

Table 4.16 shows the maximum load as a ratio of net yield load of angle, net ultimate load of angle, and ultimate shear load of bolts respectively. For angles connected by one leg, the net effective area was taken (Fisher and Struik, 1974) as:

$$A_{ne} = A_n \left( 1 - \frac{\bar{x}}{L} \right)$$

where  $A_n$  = Cross sectional area of angle less bolt holes (net area of the weakest connected member);

$\bar{x}$  = Distance between centroidal axis of the angle and the joint shear plane; and

$L$  = Length of the joint.

Actual material properties obtained during the study were used in the computations.

Results show that: -

- (i) bolt shear failure would have occurred in single bolted joints and two-bolt joints of Test Series C as shown by high values of the ratio of maximum load to ultimate shear load of bolts; and
- (ii) low values of the ratio of maximum load to net yield load of angle and the ratio of maximum load to net ultimate load of angle in Test Series C indicate that the method of connection employed in that test series is an inefficient way of making a joint, due to bending moment introduced at the joint by the eccentricity within it.

Typical load versus total joint deformation diagrams obtained in Test Series A, B, and C are shown in Figures 4.1, 4.20, and 4.36 respectively. Following distinct differences and similarities were observed: -

- (i) In all the test series, the region of frictional load transfer was elastic and has a higher stiffness than at any other stage of the loading process;
- (ii) In Test Series B and C, the region of slip was at approximately a constant load, while in Test Series A it was at a varying load but at a lower stiffness value;
- (iii) All the test Series had an elastic portion of load transfer by bolt bearing. In Test Series B and C, this load transfer took place in one region, while in Test Series A there were two distinct regions, one in which bolts transferred the load by bearing and another in which load was transferred by bolts in bearing as well as by direct contact of top and bottom angles;
- (iv) All the test series had an inelastic portion just before reaching maximum load and in all test series angles developed plasticity; and
- (v) All the test series showed a falling curve after reaching maximum load. In Test Series A and C this was one smooth curve, while in Test Series B this region consisted of two distinct curves one depicting failure of the gusset and the other depicting failure of the angle end.

Five bolts were tested using the Skidmore-Wilhelm Hydraulic Bolt Calibrator to determine the bolt force developed by the clamping torque that was used throughout the test program. The clamping torque used was 84ft-lbs (114.17 kN-mm), which was the value used by Manitoba Hydro on their transmission line towers. The test gave a mean value of force developed in the bolt as 35.67 kN with a coefficient of variation of 12.34 percent, showing good consistency of results.

Table 4.17 shows  $A_{nc}/A_g$  and  $A_s/A_{nc}$  ratios of the specimens of the Test Series A, B, and C. Results show that: -

- (i) high values of  $A_{nc}/A_g$  in Test Series A, Test Series B, and three-bolt and four-bolt joints of Test Series C show that load carrying capacity of the angle is not weakened by the introduction of the joint;
- (ii) high values of  $A_s/A_{nc}$  in Test Series A, Test Series B, and four-bolt joint of Test Series C show that adequate number of bolts were available to match the load carrying capacity of the smallest angle. Values greater than 1.00 in Test Series A and Test Series B show that number of bolts provided were too many. Also a low  $A_s/A_{nc}$  value of 0.38 for single bolted joints in Test Series C shows that a shear failure of bolt is possible in that joint, while in all other joints angle or gusset failures are likely;
- (iii) values of maximum load indicated that three-bolt joint of Test Series C was the most efficient in developing the load carrying capacity of the smallest angle framing into the joint; and
- (iv) values of average shear stress in a bolt at failure show that bolt shear failure is most likely in single bolted joints of Test Series C.

Idealized load versus deformation diagrams from Test Series A, B, and C are shown in Figures 4.17, 4.18, 4.19, 4.32, 4.33, 4.34, 4.56, 4.57, and 4.58 respectively. Diagrams of Test Series A differed from each other by the values of B (load at the end of slip). Diagrams of Test Series B differed from each other by the value of P (extent of slip). Diagrams of Test Series C for a given number of bolts differed from each other by the value of P (extent of slip).



The current practice of providing a normal construction clearance of 1/16 in. (1.59 mm) was considered satisfactory for the following reasons: -

- (i) The maximum slip that can occur in such a joint is 1/16 in. (1.59 mm). Fisher et al. (1974) and Chesson (1965) have reported that field practice has shown that joint slips are rarely as large as 1/16 in. (1.59 mm) and average less than 1/32 in. (0.80 mm). Results of this study indicate that normal construction clearance (see Table 4.12) slips ranging from 0.22 to 1.03 mm can be expected and these results conform to the findings of above researchers. In many situations, the joint slip is less because some bolts may be in bearing due to small misalignments inherent in the shop production and fabrication processes. This is particularly true for multi-bolt and multi-member joints;
- (ii) With a small construction clearance, misalignment of bolts is possible. As considerable ductility is available in angles and bolts used in electric transmission line towers, such misalignment will have a beneficial effect. It improves slip resistance, offers a stiffer joint and does not result in a decrease in joint strength (Vasarheli and Chang, 1965); and
- (iii) Results show that maximum construction clearance increases the slip (see Table 4.12) considerably from the range of 0.22 to 1.03 mm of normal construction clearance to the range of 0.90 to 2.35 mm.

#### **4.6 ANALYSIS OF RESULTS OF TEST SERIES D**

The Test Series D dealt with bolt calibration by the turn-of-nut method. Results are shown in Figures 4.63 and 4.64. Eleven bolts, consisting of ten B33.4 grade 5 bolts

and one A325 bolt, were tested using the custom designed special test rig (see Figure 4.63). Nine bolts, consisting of five B33.4 grade 5 bolts and four A325 bolts, were tested using the Skidmore-Wilhelm Hydraulic Bolt Calibrator (see Figure 4.64).

The conclusions made from bolt calibration tests by the turn-of-nut method are shown below.

Flattening of lock washers is not an event of significance because it happens at a very low load ranging from 300 to 1,530 lbs (1.34 to 6.82 kN) and well before the snug position at a number of turns varying from 1 1/2 to 2 1/6 from the “finger-tight” position.

Number of turns required to attain the snug position was variable and ranged from 1 11/12 to 2 7/12 turns from the “finger-tight” position, or 1/4 to 5/12 turns from the position at which lock washer was flattened. However, the force induced in the bolt at the snug position was consistent and ranged from 7,436 to 9,295 lbs (33.16 to 41.45 kN), and differed from the value of 10,000 lbs (44.59 kN) usually associated with friction type bolts.

Mean of the maximum load induced on the bolt before failure was 12,405.80 lbs (55.32 kN) with a coefficient of variation of 20.21 percent. This was lower than the tensile load of 27,100 lbs (120.84 kN) specified by CAN B33.4 (1973) for the bolt of grade 5. This difference can be attributed to the development of torsional shear stresses in the bolt shank in addition to tensile stresses during torque tensioning.

Three modes of bolt failure (see Figure 4.65 and legend of Figure 4.63) were observed and they were: torsional shear failure at the root of the thread, thread failure between the bolt and the nut, and lock washer failure by opening out resulting in misalignment of the nut and release of the bolt load. It should be noted that failure could

not be reached (see Figure 4.66) in tests using Skidmore-Wilhelm Hydraulic Bolt Calibrator, as this calibrator is not designed to calibrate a B33.4 grade 5 bolt since the dimensional properties of this bolt is smaller than those of a A325 bolt. Further, the bolt length of both 5/8 inches (15.88 mm) diameter B33.4 grade 5 bolts and A325 bolts was not long enough to provide a good grip for the nut.

These bolts are not suitable for friction type bolted connections as thread yielding occurs at 1/6 to 5/12 turns from the snug position. Note that CAN/CSA-S16.1-94 (1995) recommends tightening the nut by 1/3 of a turn beyond the snug position for a friction type bolt of the size tested.

Variation of behavior after thread yielding is likely to be greater when a tensile load is applied to a bolt by turning the nut, as items tested are varying continuously as the bolt shank gets shortened by the turn of the nut and new portions of bolt thread are engaging the nut. Hence it is not a suitable test for comparing the behavior of bolts, but has only a limited value for determination of load induced at the snug position and the number of turns that the nut can be tightened from the snug position before threads begin to yield.

Loss of load immediately after tightening the nut can be attributed to the reduction of deformation due to release of applied torque and the nut slipping back while it develops friction between threads to prevent the nut being pushed back. Increase of load immediately after tightening the nut can be attributed to the increase in the effective area of the bolted material resisting the bolt clamping force due to better contact between different materials resisting the bolt clamping force. The former effect is more common, while latter sometimes occurs in A325 bolts due to their larger nuts and larger heads.

Behavior of A325 bolts under torqued tension was very different from that of B33.4 grade 5 bolts, since A325 bolt has a wider bolt head, a wider nut, and a thicker nut, while more threads in the nut engage the bolt. All these factors contribute to produce a better stress distribution in the A325 bolt.

Application of tensile load in the bolt by tightening the nut was found to reduce (Fisher and Struik, 1974) the tensile load that the bolt can carry by about 85 percent due to torsional shear stresses induced during tightening, in the case of black bolts. A further reduction of 25 percent was reported by Brookhart et al. (1968) and Fisher et al. (1974) for galvanized bolts by the zinc layer on the bolt threads, galling in the threads, and seizing when the bolt is tightened. A reduction of tensile load by 40.3 percent was reported by Brookhart et al. (1968) for manual torquing of galvanized 3/4 in. (19 mm) diameter A325 bolts compared to power torquing of those bolts. In these tests B33.4 grade 5 bolts reached 49 percent to 57 percent of the tensile load of the bolt. These differences can be attributed to: (i) longer and larger diameter bolts tested by previous researchers; (ii) manual tightening used in these tests reduce the tensile load compared to power wrench tightening due to absence of vibration (Fisher and Struik, 1974); and (iii) galvanized threads, smaller nut, and smaller head of B33.4 grade 5 bolt give rise to a greater reduction than for A325 bolts. Considering the fact that the A325 bolt has a better stress distribution than that of B33.4 grade 5 bolt, a reduction of 49 percent to 57 percent of tensile load by torque tightening obtained in this study was considered comparable with the findings of previous researchers (Fisher and Struik, 1974).

#### **4.7 ANALYSIS OF RESULTS OF TEST SERIES E**

The Test Series E dealt with direct tension tests on bolts. Results are shown in Table 4.18 and Figures 4.67 to 4.69. Nine bolts, consisting of five B33.4 grade 5 bolts, three A325 galvanized bolts and one A325 non-galvanized bolt, were tested in direct tension.

ASTM A325-86a (1993) and A325M-86 (1993) on high strength bolts for structural steel joints recommends the wedge tension test for determining the mechanical properties of bolts, but allows using the direct tension test on full size bolts as an alternative. ASTM A394 (1993) on steel transmission tower bolts and CSA B33.4 (1973) on galvanized steel tower bolts recommend the wedge tension test. In this study, the direct tension tests on bolts were used in preference to the wedge tension tests for the following reasons: -

- I. As the bolts used in this study were very short in length, the wedge tension tests require the replacement of the nut of the bolt by a special attachment device. This will not allow a proper study of the load transfer between the nut and the bolt, which is a very critical consideration for this type of bolts;
- II. According to ASTM F606 (1993), the purpose of the wedge tension test is to obtain the tensile strength and demonstrate the “head quality” and ductility of the bolt. Investigators of bolt brittleness (Gill and Hansen, 1966) have generally used this test and in the case of brittle bolts the fracture of the fastener has often been reported to occur at the juncture of the bolt head and shank rather than in the thread area. As the bolts in this study were known to have considerable ductility, the wedge tension test was not considered useful;

- III. The wedge tension test allows an easy assessment of two properties, namely bolt brittleness and its tensile load carrying capacity, by one test method. However, most previous researchers have conducted the direct tension test as this test allows the determination of mechanical properties more realistically as it does not induce large bending stresses in the bolt shank;
- IV. The wedge tension test does not represent actual condition of the bolt in service as the bolt head is normally well seated making full contact with materials being connected, where necessary by the use of a washer which has a uniformly sloping surface; and
- V. Some standards (ASTM A325-86a, 1993; ASTM A325M-86, 1993), which recommend the wedge tension test, also recommend the direct tension test as an alternative test.

The conclusions made from the tensile test results on both types of bolts, B33.4 Grade 5 bolts and A325 bolts are presented below.

The mean tensile strength expressed in kips for B33.4 bolts was 30.25 kips with a coefficient of variation of 8.06 percent. Those for A325 bolts were 31.46 kips and 1.32 percent respectively. Both types of bolts satisfy the minimum required tensile strength of 27.1 kips and show very consistent results as indicated by low values of coefficient of variation.

The mean tensile strength expressed in MPa based on “stress area” (Fisher and Struik, 1974) for B33.4 bolts was 899.87 MPa with a coefficient of variation of 8.27 percent. Those for A325 bolts were 943.11 MPa and 1.62 percent respectively. Both

types of bolts satisfy the minimum required tensile strength of 840 MPa or 120 ksi and show very consistent results as indicated by low values of coefficient of variation.

As “stress area” accounts for the fact that the weakest section of any bolt in tension is at the threaded portion, the tensile strength based on “stress area” (Wallaert and Fisher, 1965) is a better parameter to compare the performance of two types of bolts. The results show that the two types of bolts are substantially similar in their capacity to carry tensile loads, although B33.4 bolt heads and nuts are smaller in size.

All the tested B33.4 bolts showed thread failure (see Figure 4.69), while all the tested A325 bolts showed tensile failure of bolt shank at the root of the thread. This can be attributed to the thinner nut and the lesser number of threads participating in the load transfer in the former type of bolts. The latter type of failure is more advantageous with respect to maintenance, as a bolt can be replaced easily when excessive deformation is observed since the nut does not get jammed. The former type of failure is more gradual and not sudden, but the nut invariably gets jammed. However, it is not a serious drawback as most of these tower bolts are carrying shear loads as opposed to tensile loads.

The load versus elongation characteristics of a bolt are considered to be more significant than the stress versus strain characteristics of the parent metal, because performance is affected by the presence of the threads since the stress varies along the bolt as a result of the gradual introduction of force from the nut and the change in section from the threaded to the unthreaded portion. The load versus elongation diagrams (see Figures 4.67 to 4.68) show that B33.4 bolts have less scatter in the elastic region and greater scatter in the plastic region. A325 bolts show the exact opposite. Longer

unthreaded bolt shank of the former type can be attributed to less scatter in the elastic response, while considerable necking before failure of A325 bolts can be attributed to less scatter in the plastic response. The load versus elongation curves obtained compare well with those reported by Gill et al. (1966), Vasarhelyi et al. (1967), and Christopher et al. (1966).

No previous researcher has reported the modulus of elasticity value of the bolt, probably because it is laborious to compute and requires simplifying assumptions to determine the modulus of elasticity value. Moreover, the value so obtained is not readily comparable since the ratio of threaded and unthreaded portions of the bolt shank varies among different studies. Hence, no attempt was made to determine the modulus of elasticity value of a bolt in this study too.

The mean strain at failure of B33.4 bolts was 0.089 mm/mm with a coefficient of variation of 12.77 percent. Those for A325 bolts were 0.146 mm/mm and 3.90 percent respectively. The results of A325 bolts are more consistent and can be attributed to considerable necking observed before failure.

The mean bolt elongation at failure of B33.4 bolts was 0.148 inches (3.76 mm) with a coefficient of variation of 8.55 percent. Those for A325 bolts were 0.219 inches (5.56 mm) and 3.65 percent respectively. These values compare well with 0.14, 0.13, 0.24, and 0.25 inches reported by Vasarhelyi et al. (1967), Christopher et al. (1966), Rumpf et al. (1963), and Fisher et al. (1968) respectively, considering that some of those values were for very long bolts. As the B33.4 bolt has a shorter thread length under direct tension, it results in a decrease in deformation capacity, compared to an equivalent A325 bolt. This similar behavior was also observed and reported by Sterling et al. (1965).



#### **4.8 ANALYSIS OF RESULTS OF TEST SERIES F**

The Test Series F dealt with tension tests on steel angle sections. Test results are shown in Table 4.19 and Figures 4.70 and 4.71. As the results gave a sharp-kneed stress-strain diagram, in accordance with ASTM A370 (1993), yield point was taken as the stress corresponding to the top of the knee.

Results of percent elongation and percent reduction in area could not be compared with those of previous researchers because they have used either thicker test specimens or a gauge length of 8 inches (200 mm).

The following conclusions can be made from the tensile test results on angle coupons: -

- 1) The coefficients of variation of yield strength, tensile strength, modulus of elasticity, percent of elongation, and percent of reduction in area ranged from 2.38 percent to 7.89 percent indicating good consistency of the test results;
- 2) The mean modulus of elasticity was 214.67 GPa, which compares favorably with the usual value for steel that is 200 GPa (CAN/CSA-S16.1-94, 1995);
- 3) All the results of yield strength satisfied the minimum requirement of 300 MPa specified in CAN/CSA-G40.21-M87 (1987). The observed mean value of 347.56 MPa, moreover, compared well with 369.6 MPa reported by Sakla et al. (1999);
- 4) All the results of tensile strength satisfied the requirement of 450 to 620 MPa specified in CAN/CSA-G40.21-M87 (1987);
- 5) All the results of percent of elongation satisfied the minimum requirement of 20.5 specified in CAN/CSA-G40.21-M87 (1987) and CSA G40.20/G40.21-98 (1998);

- 6) Percent of reduction in area ranged from 52.96 to 59.67 showing considerable ductility in the tested steel. It should be noted that percent of reduction in area is not a requirement for steel angles;
- 7) Stress-strain diagrams (see Figure 4.70) showed a substantial plastic range and a substantial strain-hardening range indicating the tested steel was very ductile;
- 8) Galvanized surface peeled off at the middle of the specimen (see Figure 4.69) at a strain of around 0.15 mm/mm; and
- 9) The mean of the ratio of tensile strength to yield strength of 1.46 was much greater than 1.05 suggested (Dhalla and Winter, 1974) to be the minimum requirement for strain-hardenability of steels suitable for structural applications.

#### **4.9 CONCLUSIONS**

The overall conclusions made from the test results of the experimental investigation are shown below.

In the splice joint under compression (Test Series A) centroidal axis of the specimen varied along the specimen. Although the specimen is under a varying bending moment distribution, magnitudes of bending moments were small in comparison to compressive forces.

The main differences between different load versus total joint deformation diagrams of Test Series A were found to be the following: -

- (i) Extent of slip “Q” (see Figure 4.1) was highest for joints with maximum construction clearance at assembly, lowest and virtually non-existent for

joints set in bearing at assembly; and an intermediate value for joints with normal construction clearance at assembly; and

- (ii) Period of load transfer with top and bottom angles in direct contact with each other (see S in Figure 4.1) commences at a larger deformation for joints with maximum construction clearance at assembly, a smaller deformation for joints set in bearing at assembly, and an intermediate deformation for joints with normal construction clearance at assembly.

A typical load versus total joint deformation diagram (see Figure 4.1) of Test Series A was found to have the following distinct segments: -

- (i) A segment of elastic frictional load transfer (ab);
- (ii) A segment of slip at a very reduced stiffness, or at an approximately constant load and thereafter at very reduced stiffness (bc);
- (iii) A segment of elastic load transfer by bolt bearing (cd);
- (iv) A segment of elastic load transfer (de) at a higher stiffness value, when the top angle makes direct contact with the bottom angle to transfer load directly as well as through the splice angle;
- (v) A segment of non-linear load transfer (ef) extending up to the maximum load, where the top angle (smallest angle) develops plastic deformations leading up to buckling; and
- (vi) A segment commencing from maximum load and leading up to failure of top angle (fg), where the top angle rapidly loses its load carrying capacity due to onset of buckling.

Only one mode of failure was observed in the Test Series A. It consisted of the top angle slipping down to make direct contact with the bottom angle, followed by the development of plastic deformation in the top angle, the smallest angle, leading to failure by buckling.

Load at the end of load transfer through splice angle only (see C in Figure 4.1) is defined as the load at which mode of load transfer changes from via splice angle only to via splice angle and direct contact of top and bottom angles. Stiffness increases sharply at this point since area of cross section transferring compression load increases significantly.

Load at onset of plasticity (see D in Figure 4.1) is defined as the load at which elastic response of the joint changes to non-linear behavior due to the development of plastic bending in the top angle (smallest angle). Load per bolt values of Test Series A at the onset of plasticity are very consistent as shown by the coefficient of variation of 3.28 percent (see Table 4.1). Lower coefficient of variation also indicates that the load at onset of plasticity is not dependent on the condition of construction clearance at assembly.

Maximum load (see E in Figure 4.1) is defined as the highest load reached by the bolted joint during a test. Load per bolt values at maximum load in Test Series A are the most consistent as shown by the lowest coefficient of variation of 1.74 percent. The consistency of maximum load indicates that (i) maximum load is independent of the condition of construction clearance at assembly; and (ii) inherent ductility of the specimens ensures that any inadvertent deviations in fabrication and testing processes are evened out by plastic deformation.

Extent of slip (see Q in Figure 4.1) is defined as the slip that takes place at a very reduced stiffness, or at an approximately constant load and thereafter at a very reduced stiffness. In Test Series A, no slip was observed (see Table 4.2) for joints set in bearing at assembly except the faulty specimen AB2. Those with maximum construction clearance gave the highest extent of slip values, while those joints with normal construction clearance gave intermediate extent of slip values.

Deformation during load transfer through the splice angle only (see R in Figure 4.1) is defined as the joint deformation that occurs during elastic load transfer by bolts in bearing with the entire load transfer being affected via the splice angle. These deformation values show the least coefficient of variation among all other deformation values (see Table 4.2). This can be attributed to lack of influence of construction clearances, and other fabrication and testing irregularities as all bolts are in bearing at this stage.

Elastic stiffness before slip (see  $\theta_1$  in Figure 4.1) is caused by the frictional load transfer and the mobilization of a greater area of effective cross section to resist the load. For this reason, elastic stiffness before slip is greater than the elastic stiffness at any other stage of the loading process. Elastic stiffness before slip values show some variability in Test Series A, though not excessive, as shown by the coefficient of variation of 23.54 percent (see Table 4.2). This can be attributed to the fact that higher accuracy of measurement cannot be maintained as load at commencement of slip as well as the corresponding deformation are rather small.

Elastic stiffness during slip (see  $\theta_2$  in Figure 4.1) is either zero or very small. The values in Test Series A show remarkable consistency as shown by a low coefficient of

variation of 14.37 percent (see Table 4.2). This confirms the fact that bolt clamping forces were uniformly applied throughout the test series. A small stiffness at slip was reported by the previous researchers (Vasarhelyi et al., 1959; Vasarhelyi et al., 1965; Fisher et al., 1974) due to misalignment of holes. This indicates that in some tests small inadvertent misalignments would have existed.

Elastic stiffness during load transfer only by the splice angle (see  $\theta_3$  in Figure 4.1) does not depend on construction clearance at assembly as all the bolts are in bearing at this stage. The values in Test Series A show remarkable consistency as shown by a low coefficient of variation of 15.51 percent (see Table 4.2).

Elastic stiffness during load transfer by direct contact between top and bottom angles as well as via splice angle (see  $\theta_4$  in Figure 4.1) does not vary with construction clearance at assembly as all bolts are in bearing at this stage too. These values in Test Series A are the most consistent of the different types of stiffness observed in the loading cycle as shown by a coefficient of variation of 11.25 percent (see Table 4.2).

In this entire test program the clamping force used per bolt is 35.67 kN, which is the usual value used by Manitoba Hydro during erection of their transmission line towers.

Kennedy (1972) reported a value of 0.153 for the slip coefficient of galvanized joints and Brookhart et al. (1968) reported values ranging from 0.19 to 0.25. These observed values were higher due to bigger washers used for the galvanized angle joints. The values show good consistency as shown by the coefficient of variation of 7.99 percent (see Table 4.3). The joints set in bearing during assembly were excluded as there was no frictional load transfer in these joints. Hot-dip galvanizing results (Fisher and Struik, 1974) in a lower frictional resistance of the faying surfaces. Higher variability of

slip resistance is often due to the variability in thickness of the metallic layer resulting from the galvanizing process. Fisher et al. (1974) have reported a coefficient of variation of 38.1 percent for joints with “as received” galvanized surfaces, and results of this test series show good tolerance in the thickness of the galvanized coating.

Basic shapes of load versus total joint deformation diagrams of Test Series A were similar except for the following: -

- (i) Extent of slip was highest for joints with maximum construction clearance at assembly, none for joints set in bearing at assembly except faulty joint AB2, and intermediate for joints with normal construction clearance at assembly; and
- (ii) Slip consisted of either slip at a very reduced stiffness, or at an approximately constant load and thereafter at a very reduced stiffness.

The following effects were observed in the diagrams (Figures 4.8 to 4.10), which show typical variations of individual bolt row deformation and total joint deformation with load for joints of Test Series A: -

- (i) Total joint deformation of a specimen was always greater than deformation of each individual row of bolts;
- (ii) Most often the lowest deformation was recorded by the lowest row of bolts in the bottom angle (L4). This means that most often the lowest row of bolts in the bottom angle is least stressed and hence carries a lower load;
- (iii) Most often the highest deformation was recorded by the highest row of bolts in the top angle (L1). This means that most often the highest row of bolts in the top angle is stressed most and hence carries a higher load; and

- (iv) After reaching maximum load, deformation in either bolts at level 1 (L1), bolts at level 2 (L2), or bolts at level 3 (L3) of a specimen reverses and decreases as point of failure approaches. Most often this happens in lower row of bolts of the top angle (L2) in the case of joints with maximum construction clearance at assembly, and in bolts of the bottom angle (L3 and L4) in the case of joints with normal construction clearance or joints set in bearing at assembly. In the latter case greatest reversal occurs in the higher row of bolts of the bottom angle (L3). These can be attributed to the varying bending moments developed due to changing eccentricity along the specimen during the buckling process dependent on the actual buckling profile of each specimen.

The following effects were observed in the diagrams (Figures 4.11 to 4.13), which show typical variations of top joint deformation, bottom joint deformation, and total joint deformation with load for joints of Test Series A: -

- (i) Total joint deformation of a specimen was greater than deformation of either top angle joint or bottom angle joint;
- (ii) Highest deformation was always recorded at the top angle joint, while lowest was at the bottom angle joint. This shows that although the shear load transferred through top angle joint and bottom angle joint is the same, the different bending moments induced and the mating leg sizes affect the deformations at top and bottom angle joints; and
- (iii) After reaching maximum load, deformation in the bottom angle joint reversed and decreased as point of failure approached in all joints with normal



construction clearance at assembly and two of the three joints, AB1 and AB3, set in bearing at assembly. Note that specimen AB2 showed a slip (see Figure 4.4 and Table 4.2) indicating that it had some clearance at assembly and thus resembles joints with maximum clearance.

The following effects were observed in the diagrams (Figure 4.14 to 4.16), which show typical variations of deformation of portions of top angle, bottom angle, and splice angle between two bolt rows of top or bottom joints, with load for joints of Test Series A:

-

- (i) In all the specimens, highest deformation was observed in the portion of top angle within the top joint, due to its smaller cross sectional area;
- (ii) Smallest deformation was observed in the portion of bottom angle within the bottom joint, due to its larger cross sectional area; and
- (iii) After reaching maximum load, most often, deformation in the portions of bottom angle (B3B4) within the bottom joint reversed and decreased as point of failure approached. This can be attributed to the development of bending moments in the bottom angle due to buckling profile undergone by the specimen.

The following effects were observed in the idealized load versus deformation diagrams developed for joints in Test Series A (Figures 4.17 to 4.19): -

- (i) Governing parameters ( $A$  and  $\theta_1$  in Figures 4.17 to 4.19) of the region of frictional load transfer were the same for all categories;
- (ii) There were ten governing parameters, namely  $A$ ,  $\theta_1$ ,  $B$ ,  $\theta_2$ ,  $C$ ,  $\theta_3$ ,  $D$ ,  $\theta_4$ ,  $E$ , and  $T$  (see Figures 4.17 to 4.19), for the categories of maximum construction

clearance, and normal construction clearance at assembly. The governing parameters B and  $\theta_2$  were not relevant for joints set in bearing at assembly and hence had only eight governing parameters (see Figure 4.19);

- (iii) Values of governing parameters A,  $\theta_1$ , C,  $\theta_3$ , D,  $\theta_4$ , E, and T (see Figures 4.17 to 4.19) were the same for all the three categories; and
- (iv) The governing parameter B varied for the categories of maximum construction clearance and normal construction clearance to give different values of slip. This parameter is not relevant for joints set in bearing at assembly as no slip occurred in them.

Various methods used by previous researchers to develop mathematical expressions for load versus slip (deformation) for Test Series A, variation in the joint were tried and the best fitted curve was found to be: -

**Maximum construction clearance at assembly**

- (i)  $P = 263.45\delta$  for  $0.00 \leq \delta \leq 0.16$ ;
- (ii)  $P = 20.99(\delta - 0.16) + 43.28$  for  $0.16 \leq \delta \leq 3.71$ ;
- (iii)  $P = 43.65(\delta - 3.71) + 117.77$  for  $3.71 \leq \delta \leq 5.97$ ;
- (iv)  $P = 86.55(\delta - 5.97) + 216.40$  for  $5.97 \leq \delta \leq 6.76$ ; and
- (v)  $P = 44.97(\delta - 6.76)^3 - 147.79(\delta - 6.76)^2 + 87.73(\delta - 6.76) + 285.15$   
for  $6.76 \leq \delta \leq 7.12$ ;

where  $P$  = Load on the joint in kN; and

$\delta$  = Deformation of the joint in mm;

**Normal construction clearance at assembly**

- (i)  $P = 263.45\delta$  for  $0.00 \leq \delta \leq 0.16$ ;

- (ii)  $P = 20.99(\delta - 0.16) + 43.28$  for  $0.16 \leq \delta \leq 1.89$  ;
- (iii)  $P = 43.65(\delta - 1.89) + 79.49$  for  $1.89 \leq \delta \leq 5.03$  ;
- (iv)  $P = 86.55(\delta - 5.03) + 216.40$  for  $5.03 \leq \delta \leq 5.82$  ; and
- (v)  $P = 44.97(\delta - 5.82)^3 - 147.79(\delta - 5.82)^2 + 87.73(\delta - 5.82) + 285.15$   
for  $5.82 \leq \delta \leq 6.18$  ;

where  $P$  = Load on the joint in kN; and

$\delta$  = Deformation of the joint in mm;

**Set in bearing at assembly**

- (i)  $P = 263.45\delta$  for  $0.00 \leq \delta \leq 0.16$  ;
- (ii)  $P = 43.65(\delta - 0.16) + 43.28$  for  $0.16 \leq \delta \leq 4.13$  ;
- (iii)  $P = 86.55(\delta - 4.13) + 216.40$  for  $4.13 \leq \delta \leq 4.92$  ; and
- (iv)  $P = 44.97(\delta - 4.92)^3 - 147.79(\delta - 4.92)^2 + 87.73(\delta - 4.92) + 285.15$   
for  $4.92 \leq \delta \leq 5.28$  ;

where  $P$  = Load on the joint in kN; and

$\delta$  = Deformation of the joint in mm.

Feasibility of interpolation or extrapolation of the load-deformation relationship for similar joints with less or more number of rows of bolts was considered for Test Series A. Results of Test Series C (see 4.4) indicate that the load-deformation diagrams of joints can be interpolated or extrapolated for joints similar in configuration but differing in number of bolts. Hence interpolation or extrapolation of load-deformation relationship for similar joint configurations can be recommended and further research is necessary to obtain regression equations of the governing parameters. This requires

further testing of specimens with the number of bolt rows increased or decreased in this type of joint.

The main differences between different load versus total joint deformation diagrams of Test Series B was found to be the following: -

- (i) Length of slip “P” (see Figure 4.20) was highest for maximum construction clearance at assembly, lowest and virtually non-existent for bearing, and an intermediate value for normal construction clearance at assembly; and
- (ii) Portions “ef” and “gh” showed kinks if either the gusset developed a second crack or the two angles cracked one after the other.

A typical load versus total joint deformation diagram (See Figure 4.20) of Test Series B was found to have the following distinct segments: -

- (i) A segment of elastic frictional load transfer (ab);
- (ii) A segment of slip at approximately constant load or very reduced stiffness (bc);
- (iii) A segment of elastic load transfer by bolt bearing (cd);
- (iv) A segment of non-linear load transfer extending up to the maximum load, where the portion of the gusset between vertex of the gusset and the first bolt hole undergoes plastic tensile deformation (de);
- (v) A segment commencing from maximum load and leading up to failure of load transfer of the bolt closest to the vertex of the gusset, due to cracking of the gusset between bolt hole and exterior edge, either on one side or both sides (ef). If both sides of the gusset cracked one after the other, an additional kink was also developed in the segment “ef”;

- (vi) A segment of non-linear load transfer, at a very mild slope, extending up to a second peak of the load where the portion of the angle between the end face of the angle and its closest bolt hole undergoes plastic deformation where bulging can be seen by the naked eye (fg); and
- (vii) A segment (gh) commencing from second peak of the load and leading up to failure of load transfer of the bolt closest to the end face of the angle due to cracking of the angle between bolt hole and end face of the angle, either on one angle or both angles. If the two angles cracked one after the other, an additional kink was also developed in the segment “gh”.

The Test Series B gave remarkably consistent test results in comparison to those of Test Series A and C, because of symmetrical nature of the loading with no eccentricities and the absence of buckling effects, which are variable and influenced by local imperfections in the specimens.

Following modes of failure were observed in the Test Series B: -

- (i) A failure mode with the gusset near vertex cracking (see Figure 4.21) on one side followed by cracking of both of the angles (see Figure 4.22) at their ends simultaneously (see Figure 4.23);
- (ii) A failure mode with the gusset near vertex cracking on one side followed by cracking of the two angles at their ends one after the other (see Figure 4.23);  
and
- (iii) A failure mode with the gusset near vertex cracking on both sides followed by cracking of the two angles at their ends one after the other (see Figure 4.24).

In Test Series B, the load at commencement of slip (see A in Figure 4.20), which is defined as the load at which significant slip takes place at constant load or at a very reduced stiffness, was very consistent with a coefficient of variation of 9.96 percent.

In Test Series B, the load at onset of plasticity (see B in Figure 4.20), which is defined as the load at which elastic response of the joint changes to non-linear behavior due to development of plastic deformation at the vertex of the gusset, was consistent as shown by its low coefficient of variation (9.14 percent).

Maximum load (see C in Figure 4.20) is defined as the highest load reached by the bolted joint during a test. In Test Series B, values of equivalent single shear load per bolt at maximum load show the greatest consistency (see Table 4.4) as shown by the very low value of coefficient of variation (2.07 percent). Their mean value (51.27 kN) is lower than the specified single shear load for a bolt with a diameter of 5/8 inches (16 mm) in accordance with CAN/CSA-S16.1-94 (1995) (72.5 kN), since in multiple bolt joints, bolts may not share the load equally.

Extent of slip (see P in Figure 4.20) is defined as the slip that takes place approximately at constant load or at very reduced stiffness. In Test Series B, no slip was observed (see Table 4.5) for joints, which were set in bearing during assembly. Those joints with maximum construction clearance gave the highest values of extent of slip, while those joints with normal construction clearance gave intermediate values. Neither the joints with maximum construction clearance nor the joints with normal construction clearance slipped to their respective maximum possible extents of 3.18 or 1.59 mm due to restrictions caused by fabrication tolerances when more than two members mate at the joint.

Deformation between end of slip and onset of plasticity (see Q in Figure 4.20) varies elastically with the load, and most bolted joints in service function in this range. It is independent of construction clearance at assembly as bolts are in bearing at this stage. In Test Series B, results show less consistency (see Table 4.5) as indicated by the coefficient of variation of 21.62 percent, due to variability in the local imperfections of the gusset area near the vertex, which yielded first.

Deformation between onset of plasticity and maximum load (see R in Figure 4.20) varies non-linearly with load. It is independent of construction clearance at assembly as bolts are in bearing at this stage too. In Test Series B, results show better consistency (see Table 4.5) as indicated by the coefficient of variation of 15.58 percent. This can be attributed to the fact that stress concentrations, caused by the joint configurations as well as fabrication and testing errors, are all evened out at maximum load due to the ductility available in the steel.

Tests were concluded when the specimens ceased to take any further load. As the specimens were loaded in tension in Test Series B, failure was distinct and easy to detect unlike compression specimens of Test Series A and C. Deformation from maximum load to complete failure (see S in Figure 4.20) was substantial and the coefficient of variation of 16.52 percent indicates that the results were consistent. This high extent of deformation gives adequate warning before failure in transmission towers employing these joints.

Elastic stiffness before commencement of slip is caused by the frictional load transfer and the mobilization of a greater area of effective cross section to resist the load. For this reason, elastic stiffness before commencement of slip is greater than the elastic

stiffness after slip. In specimens of Test Series B set in bearing at assembly (see Table 4.5), corresponding stiffness could also be found as stiffness during frictional load transfer and stiffness during bolt bearing were observed distinctly in this test series. Values of elastic stiffness before commencement of slip show good consistency (see Table 4.5) as indicated by the coefficient of variation of 7.71 percent due to symmetrical nature of the loading with bolts in double shear.

Values of elastic stiffness after slip (see Table 4.5) were consistent in Test Series B with a coefficient of variation of 12.49 percent. The considerable load range and deformation range covered during this stage make measurements accurate and thereby contribute to consistency.

In Test Series B, the values of the ratio of elastic stiffness before commencement of slip to elastic stiffness after slip are greater than 2.95 due to the fact that effective cross sectional area at the joint after slip is reduced. Results show consistency as indicated by the coefficient of variation of 12.94 percent (see Table 4.5).

In Test Series B, the observed values of the slip coefficient compare well with values reported in the literature, which were all bolted joints in double shear. The values also show good consistency as shown by the coefficient of variation of 9.96 percent. The joints set in bearing during assembly were excluded as there was no frictional load transfer in these joints.

In joints of Test Series B, the basic shapes of load versus total joint deformation diagrams (Figures 4.25 to 4.27) were similar except for the following: -



- (i) Extent of slip was highest for joints with maximum construction clearance at assembly, none for joints set in bearing at assembly, and intermediate for joints with normal construction clearance at assembly;
- (ii) Slip consisted of either slip at approximately constant load, slip at a low stiffness or a combination of both. This can be attributed to fabrication difficulties that cause alignment problems when more than two members mate at the joint; and
- (iii) Portion of curve beyond maximum load had more kinks when more than one crack form either at the vertex of the gusset or a crack forms on one angle followed by a crack in the other angle.

Typical variations of individual bolt deformation and total joint deformation with load for joints in Test Series B show that the individual values of deformation at bolts and total joint deformation are very similar and of the same order, with lower bolt (see Figure 4.28 to 4.30) most often recording the highest deformation by a very small margin. This indicates that the lower bolt is carrying a slightly higher load, but as the difference in deformation of bottom bolt and top bolt is very small, it can be assumed that the two bolts share the load approximately equally. Further, the deformations of portions of gusset plate and angles between two bolts are negligible compared to bolt deformation values.

In Test Series B, the variations of deformations with load of the portions of gusset and angle between the two bolts of the joint are similar and extent of deformation (about 0.3 mm) is negligibly small in comparison to bolt deformation values (about 15 mm).

In Test Series B, idealized curves are shown in Figures 4.32, 4.33, and 4.34 for joints with maximum construction clearance (3.18 mm), normal construction clearance

(1.59 mm), and joints set in bearing at assembly. These are based on mean values observed during experimental studies. Variation beyond maximum load up to failure was omitted as previous researchers (Kitipornchai et al., 1994; Frye et al., 1974; Jones et al., 1982; Lui et al., 1986; Chen et al., 1987; Goldberg et al., 1963; Romsted et al., 1970; Al-Bermani et al., 1992; Cox, 1972) have also not considered this region. The following effects were observed in the results for three categories of construction clearance at assembly: -

- (i) There were seven governing parameters, namely  $A$ ,  $\theta_1$ ,  $P$ ,  $Q$ ,  $B$ ,  $R$ , and  $C$  (see Figures 4.32 to 4.34), for the categories of maximum construction clearance, and normal construction clearance at assembly. The governing parameter  $P$  was not relevant for joints set in bearing at assembly and hence these joints had only six governing parameters (see Figure 4.34);
- (ii) Values of governing parameters  $A$ ,  $\theta_1$ ,  $Q$ ,  $B$ ,  $R$ , and  $C$  (see Figures 4.32 to 4.34) were the same for all the three categories;
- (iii) The governing parameter  $P$  varied for the categories of maximum construction clearance and normal construction clearance to give different values of slip. This parameter is not relevant for joints set in bearing at assembly as no slip occurred in them; and
- (iv) When more than two members frame into a joint and when the joint contains more than 1 bolt, slip of the joint is only a small part of the construction clearance at assembly.

For the Test Series B, The best fitted mathematical expressions for load versus total joint deformation of the joint was found to be: -

### **Maximum construction clearance at assembly**

- (i)  $P = 211.38\delta$  for  $0.00 \leq \delta \leq 0.11$ ;
- (ii)  $P = 23.95$  for  $0.11 \leq \delta \leq 1.01$ ;
- (iii)  $P = 51.78(\delta - 1.01) + 23.95$  for  $1.01 \leq \delta \leq 3.10$ ; and
- (iv)  $P = 0.96(\delta - 3.10)^3 - 12.25(\delta - 3.10)^2 + 51.87(\delta - 3.10) + 132.17$   
for  $3.10 \leq \delta \leq 7.09$ ;

where  $P$  = Load on the joint in kN; and

$\delta$  = Deformation of the joint in mm;

### **Normal construction clearance at assembly**

- (i)  $P = 211.38\delta$  for  $0.00 \leq \delta \leq 0.11$ ;
- (ii)  $P = 23.95$  for  $0.11 \leq \delta \leq 0.33$ ;
- (iii)  $P = 51.78(\delta - 0.33) + 23.95$  for  $0.33 \leq \delta \leq 2.42$ ; and
- (iv)  $P = 0.96(\delta - 2.42)^3 - 12.25(\delta - 2.42)^2 + 51.87(\delta - 2.42) + 132.17$   
for  $2.42 \leq \delta \leq 6.41$ ;

where  $P$  = Load on the joint in kN; and

$\delta$  = Deformation of the joint in mm;

### **Set in bearing at assembly**

- (i)  $P = 211.38\delta$  for  $0.00 \leq \delta \leq 0.11$ ;
- (ii)  $P = 51.78(\delta - 1.01) + 23.95$  for  $0.11 \leq \delta \leq 2.20$ ; and
- (iii)  $P = 0.96(\delta - 2.20)^3 - 12.25(\delta - 2.20)^2 + 51.87(\delta - 2.20) + 132.17$   
for  $2.20 \leq \delta \leq 6.19$ ;

where  $P$  = Load on the joint in kN; and

$\delta$  = Deformation of the joint in mm.

Feasibility of interpolation or extrapolation of the load-deformation relationship for similar joints with less or more number of bolts was considered for Test Series B. Results of Test Series C (see 4.4) indicate that the load-deformation diagrams of joints can be interpolated or extrapolated for joints similar in configuration but differing in number of bolts. Hence interpolation or extrapolation of load-deformation relationship for similar joint configurations can be recommended and further research is necessary to obtain regression equations of the governing parameters. This requires further testing of specimens with the number of bolts increased or decreased in this type of joint.

In Test Series C, which dealt with lap joints where angles were placed back to back, even if the loading is done to simulate pure shear in the bolt or bolts, bending moments develop in the angle sections at the bolted joint, and the joint rotates from vertical at higher loadings. This rotation causes the shear load on the bolt to reduce (see Figure 4.35) and the tensile load to increase. Similar effect was reported by Fisher et al. (1974) for plate lap joints. The amount of rotation increases when specimen ends are pinned rather than fixed. The change of support conditions from pinned ends to fixed ends with limited movement up to a maximum of 4.45 degrees to take up any imperfections of the angle ends, did not alter the maximum load or other important joint properties significantly, although bolt was more severely loaded in shear.

A typical load versus total joint deformation diagram, for Test Series C, is shown in Figure 4.36. The main differences between diagrams obtained for each specimen were observed to be as follows: -

- (i) Length of slip “P” (see Figure 4.36) was highest for maximum construction clearance, lowest and virtually non-existent for bearing, and an intermediate value for normal construction clearance at assembly; and
- (ii) Three-bolt and four-bolt joints developed large deformations after reaching the maximum load indicating a tendency for the bolts to fail by shear, rather than by angle buckling.

A typical load versus total joint deformation diagram (see Figure 4.36) of Test Series C was observed to have the following distinct segments: -

- (i) A segment of elastic frictional load transfer (ab);
- (ii) A segment of slip at approximately constant load (bc);
- (iii) A segment of elastic load transfer by bolt bearing (cd);
- (iv) A segment of non-linear load transfer extending up to maximum load, where angle sections undergo plastic rotation thus rotating the bolted joint (de); and
- (v) A segment commencing from maximum load and leading up to failure either with a flatter curve (ef) showing bolt under shear deformation, or a steeper curve (eg) showing angle under buckling deformation. These findings conform with the results reported by previous researchers (Fisher et al., 1974).

In Test Series C, modes of failure observed were: -

- (i) Specimen failure with angle section reaching plastic bending failure;
- (ii) Specimen failure with bolts failing under shear along with angle sections reaching some stage of plasticity; and
- (iii) Specimen failure with the bolt shearing completely apart.

Load at commencement of slip (see A in Figure 4.36) is defined as the load at which significant slip takes places at approximately constant load. These values of Test Series C were found to be consistent with coefficient of variation values ranging from 6.87 percent to 21.89 percent. Also values of load at commencement of slip are approximately directly proportional to the number of bolts in the assembly, but do not depend on maximum or normal construction clearance at assembly.

Load at onset of plasticity (see B in Figure 4.36) is defined as the load at which elastic response of the joint changes to non-linear behavior due to development of plastic bending in the angle. These values of Test Series C have coefficients of variation values ranging from 3.33 percent to 11.52 percent (see Table 4.7) showing the consistency of the results. Further, the values of load at onset of plasticity increase with number of bolts in the assembly but not in direct proportion, and are independent of construction clearance at assembly.

Maximum load (see C in Figure 4.36) is defined as the highest load reached by the bolted joint during the test. In Test Series C, the values of load per bolt at maximum load decrease (see Table 4.7) with increasing number of bolts as loads on bolts are not distributed evenly. However, values of load per bolt at maximum load are independent of construction clearance condition at assembly, while coefficient of variation values ranging from 2.40 percent to 11.68 percent show the consistency of the results. Maximum load results also show that maximum load cannot be increased by increasing the number of bolts beyond 3 bolts as angle becomes critically stressed. Further, as demonstrated by specimen C4M1, joint loaded instantaneously showed a maximum load

not very different indicating that the loading rate may not significantly affect the maximum load of a specimen.

Extent of slip (see P in Figure 4.36) is defined as the slip that takes place approximately at constant load, which is normally a very low load value in Test Series C. No slip was observed (see Table 4.8) for joints set in bearing during assembly. Those joints with maximum construction clearance gave the highest extent of slip values, while those joints with normal construction clearance gave intermediate extent of slip values. Extent of slip changes irregularly with number of bolts and appears to be independent of the number of bolts, but dependent on construction clearance at assembly.

Extent of slip observed in Test Series C, irrespective of number of bolts in the joint, was always less than the maximum possible slip in a joint. In the case of joints with maximum construction clearance, the mean value of extent of slip was 2.21 mm while maximum possible slip was 3.18 mm. In the case of joints with normal construction clearance, the respective values were 0.85 and 1.59 mm. This can be attributed to normal tolerances likely in the shop production process and the fabrication process.

Deformation between end of slip and onset of plasticity (see Q in Figure 4.36) of Test Series C varies elastically with the load, and most bolted joints in service function in this range. It is independent of construction clearance at assembly (see Table 4.8) and number of bolts in the joint. Coefficient of variation ranged from 15.14 percent to 22.52 percent indicating that it is somewhat variable due to inconsistent nature of the onset of plasticity in the joint.

Deformation between onset of plasticity and maximum load (see R in Figure 4.36) of Test Series C varies non-linearly with load. It is independent of construction clearance at assembly (see Table 4.8) as during this stage all bolts are in bearing irrespective of the starting condition. Mean values indicate that it reduces with number of bolts (see Table 4.8). Coefficient of variation values range from 15.82 percent to 23.84 percent indicating that it is somewhat variable due to inconsistent nature of the onset of plasticity in the joint.

Testing was concluded when either the specimen takes no more load or when the load reaches 10 percent below the maximum load. In Test Series C specimens, because of buckling, specimens did not completely refuse to take load, and instead load decreased gradually with increasing deformation (see “eg” and “ef” in Figure 4.36). Hence testing was concluded before complete failure. Deformation from maximum load to 10 percent below maximum load changes with failure mode. These values were highest (in the 4-bolt specimens) when bolt shear failure was in progress (see Table 4.8), and lowest (in the 2-bolt specimens) when angle section was under elasto-plastic buckling.

In Test Series C, elastic stiffness of the joint before commencement of slip was difficult to find for joints with less bolts because slip load was very low. In general, elastic stiffness of the joint before commencement of slip (see Table 4.9) was greater than the elastic stiffness after slip.

In Test Series C, elastic stiffness of the joint before commencement of slip increased with number of bolts, but not in direct proportion. This can be attributed to increased effective area due to increased overlap length. Coefficient of variation ranged



from 17.08 percent to 24.56 percent showing that results are reasonably consistent. Further, these stiffness values are not dependent on conditions of construction clearance.

Values of elastic stiffness after slip (see Table 4.9), in Test Series C, were the most consistent of elastic stiffness measurements where coefficient of variation ranged from 7.59 percent to 26.54 percent. Further, these stiffness values were independent of the condition of construction clearance at assembly.

In Test Series C, the observed values of the slip coefficient (see Table 4.10) were little higher than those reported by Kennedy (1972) and Brookhart et al. (1968) due to bigger washers used for the galvanized angle joints. The values show good consistency as shown by the coefficient of variation ranging from 6.87 percent to 21.89 percent. Fisher et al. (1974) have reported a coefficient of variation of 38.1 percent for joints with “as received” galvanized surfaces and results of Test Series C show lesser variability. The joints in bearing during assembly were excluded as there was no frictional load transfer in those joints.

Extent of bolt deformation experienced by the three bolts of three-bolt joints in Test Series C differed after the end of slip with the total joint deformation of the joint taking a value in between those of individual bolts. In all the joints, middle bolt showed higher bolt deformation values indicating a lower stiffness. Hence greater load shares were taken by the top and bottom bolts while the middle bolt took the least load. This load sharing pattern is in conformity with the findings of Fisher et al. (1974). The differences between behavior of bolt assemblies with maximum construction clearance, normal construction clearance and those set in bearing at assembly were only in the extent of slip with the rest of behavior being similar.

Idealized load versus deformation diagrams for Test Series C are shown in Figures 4.56, 4.57, and 4.58 for joints with maximum construction clearance (3.18 mm), normal construction clearance (1.59 mm), and those set in bearing at assembly. These are based on mean values observed during experimental studies. Variation beyond maximum load up to failure was omitted as previous researchers have also not considered this region (Kitipornchai et al., 1994; Frye et al., 1974; Jones et al., 1982; Lui et al., 1986; Chen et al., 1987; Goldberg et al., 1963; Romsted et al., 1970; Al-Bermani et al., 1992; Cox, 1972). Following effects were observed in the results for three categories of construction clearance at assembly: -

- (i) Governing parameters ( $A$  and  $\theta_1$  in Figures 4.56 to 4.58) of the region of frictional load transfer, varied with number of bolts, but for a given number of bolts remained constant for all categories of construction clearance;
- (ii) There were seven governing parameters, namely  $A$ ,  $\theta_1$ ,  $P$ ,  $Q$ ,  $B$ ,  $R$ , and  $C$  (see Figures 4.56 to 4.57), for the categories of maximum construction clearance, and normal construction clearance at assembly. The governing parameter  $P$  was not relevant for joints set in bearing at assembly and hence they had only six governing parameters (see Figure 4.58);
- (iii) Values of governing parameters  $A$ ,  $\theta_1$ ,  $Q$ ,  $B$ ,  $R$ , and  $C$  (see Figures 4.56 to 4.58) varied with number of bolts, but for a given number of bolts remained constant for all the three categories of construction clearance;
- (iv) The governing parameter  $P$  varied for the categories of maximum construction clearance and normal construction clearance to give different

values of slip. This parameter is not relevant for joints set in bearing at assembly as no slip occurred in them;

- (v) Slip observed for maximum construction clearance at assembly and normal construction clearance at assembly does not depend on number of bolts. However, in each case maximum possible slip (3.18 mm and 1.59 mm respectively) never occurred in a joint. Only 69.5 percent and 53.5 percent of maximum possible slip occurs in joints with maximum construction clearance and normal construction clearance respectively due to shop production and assembly deviations; and
- (vi) Governing parameters A,  $\theta_1$ , Q, B, R, and C varied approximately linearly with the number of bolts (see Figure 4.59). The respective regression equations are also given in Figure 4.59.

For the Test Series C, the best fitted mathematical expressions for the load versus total joint deformation of the joint was found to be: -

**Maximum construction clearance at assembly**

**1. Single bolted joint**

- (i)  $P = 27.51\delta$  for  $0.00 \leq \delta \leq 0.34$  ;
- (ii)  $P = 9.29$  for  $0.34 \leq \delta \leq 2.55$  ;
- (iii)  $P = 20.34(\delta - 2.55) + 9.29$  for  $2.55 \leq \delta \leq 5.29$  ; and
- (iv)  $P = 0.17(\delta - 5.29)^3 - 3.23(\delta - 5.29)^2 + 20.39(\delta - 5.29) + 65.03$   
for  $5.29 \leq \delta \leq 11.33$  ;

where  $P$  = Load on the joint in kN; and

$\delta$  = Deformation of the joint in mm;

## 2. Two-bolt joint

- (i)  $P = 84.81\delta$  for  $0.00 \leq \delta \leq 0.24$  ;
- (ii)  $P = 20.14$  for  $0.24 \leq \delta \leq 2.45$  ;
- (iii)  $P = 44.72(\delta - 2.45) + 20.14$  for  $2.45 \leq \delta \leq 4.18$  ; and
- (iv)  $P = -0.38(\delta - 4.18)^3 - 7.35(\delta - 4.18)^2 + 44.82(\delta - 4.18) + 97.51$   
for  $4.18 \leq \delta \leq 6.73$  ;

where  $P$  = Load on the joint in kN; and

$\delta$  = Deformation of the joint in mm;

## 3. Three-bolt joint

- (i)  $P = 113.92\delta$  for  $0.00 \leq \delta \leq 0.26$  ;
- (ii)  $P = 29.28$  for  $0.26 \leq \delta \leq 2.47$  ;
- (iii)  $P = 51.49(\delta - 2.47) + 29.28$  for  $2.47 \leq \delta \leq 4.87$  ; and
- (iv)  $P = 0.88(\delta - 4.87)^3 - 14.66(\delta - 4.87)^2 + 51.42(\delta - 4.87) + 152.85$   
for  $4.87 \leq \delta \leq 7.05$  ;

where  $P$  = Load on the joint in kN; and

$\delta$  = Deformation of the joint in mm;

## 4. Four-bolt joint

- (i)  $P = 138.95\delta$  for  $0.00 \leq \delta \leq 0.34$  ;
- (ii)  $P = 46.95$  for  $0.34 \leq \delta \leq 2.55$  ;
- (iii)  $P = 65.54(\delta - 2.55) + 46.95$  for  $2.55 \leq \delta \leq 4.40$  ; and
- (iv)  $P = -1.70(\delta - 4.40)^3 - 25.28(\delta - 4.40)^2 + 65.53(\delta - 4.40) + 168.21$   
for  $4.40 \leq \delta \leq 5.56$  ;

where  $P$  = Load on the joint in kN; and

$\delta$  = Deformation of the joint in mm;

### **Normal construction clearance at assembly**

#### **1. Single bolted joint**

- (i)  $P = 27.51\delta$  for  $0.00 \leq \delta \leq 0.34$  ;
- (ii)  $P = 9.29$  for  $0.34 \leq \delta \leq 1.19$  ;
- (iii)  $P = 20.34(\delta - 1.19) + 9.29$  for  $1.19 \leq \delta \leq 3.93$  ; and
- (iv)  $P = 0.17(\delta - 3.93)^3 - 3.23(\delta - 3.93)^2 + 20.39(\delta - 3.93) + 65.03$   
for  $3.93 \leq \delta \leq 9.97$  ;

where  $P$  = Load on the joint in kN; and

$\delta$  = Deformation of the joint in mm;

#### **2. Two-bolt joint**

- (i)  $P = 84.81\delta$  for  $0.00 \leq \delta \leq 0.24$  ;
- (ii)  $P = 20.14$  for  $0.24 \leq \delta \leq 1.09$  ;
- (iii)  $P = 44.72(\delta - 1.09) + 20.14$  for  $1.09 \leq \delta \leq 2.82$  ; and
- (iv)  $P = -0.38(\delta - 2.82)^3 - 7.35(\delta - 2.82)^2 + 44.82(\delta - 2.82) + 97.51$   
for  $2.82 \leq \delta \leq 5.37$  ;

where  $P$  = Load on the joint in kN; and

$\delta$  = Deformation of the joint in mm;

#### **3. Three-bolt joint**

- (i)  $P = 113.92\delta$  for  $0.00 \leq \delta \leq 0.26$  ;
- (ii)  $P = 29.28$  for  $0.26 \leq \delta \leq 1.11$  ;
- (iii)  $P = 51.49(\delta - 1.11) + 29.28$  for  $1.11 \leq \delta \leq 3.51$  ; and

$$(iv) \quad P = 0.88(\delta - 3.51)^3 - 14.66(\delta - 3.51)^2 + 51.42(\delta - 3.51) + 152.85$$

for  $3.51 \leq \delta \leq 5.69$ ;

where  $P$  = Load on the joint in kN; and

$\delta$  = Deformation of the joint in mm;

#### 4. Four-bolt joint

$$(i) \quad P = 138.95\delta \quad \text{for } 0.00 \leq \delta \leq 0.34 ;$$

$$(ii) \quad P = 46.95 \quad \text{for } 0.34 \leq \delta \leq 1.19 ;$$

$$(iii) \quad P = 65.54(\delta - 1.19) + 46.95 \quad \text{for } 1.19 \leq \delta \leq 3.04 ; \text{ and}$$

$$(iv) \quad P = -1.70(\delta - 3.04)^3 - 25.28(\delta - 3.04)^2 + 65.53(\delta - 3.04) + 168.21$$

for  $3.04 \leq \delta \leq 4.20$ ;

where  $P$  = Load on the joint in kN; and

$\delta$  = Deformation of the joint in mm;

#### Set in bearing at assembly

##### 1. Single bolted joint

$$(i) \quad P = 27.51\delta \quad \text{for } 0.00 \leq \delta \leq 0.34 ;$$

$$(ii) \quad P = 20.34(\delta - 0.34) + 9.29 \quad \text{for } 0.34 \leq \delta \leq 3.08 ; \text{ and}$$

$$(iii) \quad P = 0.17(\delta - 3.08)^3 - 3.23(\delta - 3.08)^2 + 20.39(\delta - 3.08) + 65.03$$

for  $3.08 \leq \delta \leq 9.12$ ;

where  $P$  = Load on the joint in kN; and

$\delta$  = Deformation of the joint in mm;

##### 2. Two-bolt joint

$$(i) \quad P = 84.81\delta \quad \text{for } 0.00 \leq \delta \leq 0.24 ;$$

$$(ii) \quad P = 44.72(\delta - 0.24) + 20.14 \quad \text{for } 0.24 \leq \delta \leq 1.97; \text{ and}$$

$$(iii) \quad P = -0.38(\delta - 1.97)^3 - 7.35(\delta - 1.97)^2 + 44.82(\delta - 1.97) + 97.51$$

$$\text{for } 1.97 \leq \delta \leq 4.52;$$

where  $P$  = Load on the joint in kN; and

$\delta$  = Deformation of the joint in mm;

### 3. Three-bolt joint

$$(i) \quad P = 113.92\delta \quad \text{for } 0.00 \leq \delta \leq 0.26;$$

$$(ii) \quad P = 51.49(\delta - 0.26) + 29.28 \quad \text{for } 0.26 \leq \delta \leq 2.66; \text{ and}$$

$$(iii) \quad P = 0.88(\delta - 2.66)^3 - 14.66(\delta - 2.66)^2 + 51.42(\delta - 2.66) + 152.85$$

$$\text{for } 2.66 \leq \delta \leq 4.84;$$

where  $P$  = Load on the joint in kN; and

$\delta$  = Deformation of the joint in mm;

### 4. Four-bolt joint

$$(i) \quad P = 138.95\delta \quad \text{for } 0.00 \leq \delta \leq 0.34;$$

$$(ii) \quad P = 65.54(\delta - 0.34) + 46.95 \quad \text{for } 0.34 \leq \delta \leq 2.19; \text{ and}$$

$$(iii) \quad P = -1.70(\delta - 2.19)^3 - 25.28(\delta - 2.19)^2 + 65.53(\delta - 2.19) + 168.21$$

$$\text{for } 2.19 \leq \delta \leq 3.35;$$

where  $P$  = Load on the joint in kN; and

$\delta$  = Deformation of the joint in mm.

Using the theory of Fisher and Rumpf (1965), an analysis was carried out on distribution of bolt loads in joints of Test Series C and the main findings were: -

- (i) Proportions of load carried by each bolt fall into a general pattern in which outer bolts carry highest loads while middle bolts carry lower loads, and this pattern is in agreement with the findings of previous researchers (Fisher and Rumpf, 1965; Fisher and Struik, 1974);
- (ii) Proportions of load carried by each bolt become more divergent near ultimate load and this effect is also in agreement with the findings of previous researchers (Fisher and Rumpf, 1965; Fisher and Struik, 1974);
- (iii) Percentage loads carried by intermediate and end bolts become more uniform for joints with maximum construction clearance and most divergent for joints set in bearing for three-bolt and four-bolt joints; and
- (iv) Percentage loads, carried by end bolts of the three-bolt joint with maximum construction clearance at ultimate load, are slightly lower than expected probably because of higher percentage of error in satisfying the equilibrium equation.

In Test Series C, the variations of shear strength per bolt with number of bolts as well as length of the joint are shown in Figure 4.60, and the relationships are approximately linear. The reduction in shear strength is caused by unequal load distribution among bolts with outer bolts carrying highest loads while middle bolts carrying progressively reduced loads.

Feasibility of interpolation or extrapolation of the load-deformation relationship for joints similar in configuration but differing in number of bolts was considered. Results of Test Series C indicate that the governing parameters vary linearly (see Figure 4.59) with the number of bolts, and the value of a governing parameter for the required



number of bolts can be obtained from the regression equations (see Figure 4.59). Based on these results, extrapolation of load-deformation relationship for joints of similar configuration but differing in number of bolts can be recommended as a tentative measure, but further research should be conducted to confirm this recommendation.

Values of elastic stiffness before slip were highest in Test Series A and lowest in Test Series C. This can be attributed to increased contact area providing better composite action of the connected members in the vicinity of the joint.

The ratio of load at slip to load at onset of plasticity and the ratio of load at slip to maximum load were comparable for the three test series indicating that the region of ductile response is similar for all the tested joints.

Values of the ratio of slip to deformation reached at maximum load ranged from 0.03 to 0.44 for all the three test series. The above ratios in the work reported by Fisher et al. (1974) and Shoukry et al. (1970) for friction type bolted joints are 0.09 and 0.06 respectively. This comparison demonstrates that slip when considered in relation to deformation at maximum load is considerable in bearing type joints. Hence joint slip of bearing type joints should be separately accounted for in analytical work.

Low values of ratio of maximum load to net yield load of angle and the ratio of maximum load to net ultimate load of angle in Test Series C indicate that the method of connection employed in that test series is an inefficient way of making a joint, due to bending moment introduced at the joint by the eccentricity within it.

A comparison of load versus total joint deformation diagrams obtained in Test Series A, B, and C highlighted the following distinct differences and similarities: -

- (i) In all the test series, the region of frictional load transfer was elastic and had a higher stiffness than at any other stage of the loading process;
- (ii) In Test Series B and C, the region of slip was at approximately a constant load, while in Test Series A it was at a varying load but at a lower stiffness value;
- (iii) All the test Series had an elastic portion of load transfer by bolt bearing. In Test Series B and C, this load transfer took place in one region, while in Test Series A there were two distinct regions, one in which bolts transferred the load by bearing and another in which load was transferred by bolts in bearing as well as by direct contact of top and bottom angles;
- (iv) All the test series had an inelastic portion just before reaching maximum load and in all test series angles developed plasticity; and
- (v) All the test series showed a falling curve after reaching maximum load. In Test Series A and C this was one smooth curve, while in Test Series B this region consisted of two distinct curves one depicting failure of the gusset and the other depicting failure of the angle end.

Bolts were tested using the Skidmore-Wilhelm Hydraulic Bolt Calibrator to determine the bolt force developed by the clamping torque of 84ft-lbs (114.17 kN-mm), which was the value used by Manitoba Hydro on their transmission line towers. The tests gave a mean value of force developed in the bolt as 35.67 kN with a coefficient of variation of 12.34 percent showing good consistency of results.

The current practice of providing a normal construction clearance of 1/16 inches (1.59 mm) was considered satisfactory.

Tests on bolt calibration by turn-of-nut method revealed that flattening of lock washers is not an event of significance because it happens at a very low load ranging from 300 to 1,530 lbs (1.34 to 6.82 kN) and well before the snug position at a number of turns varying from 1 1/2 to 2 1/6 from the “finger-tight” position.

Number of turns required to attain the snug position of the nut was variable and ranged from 1 11/12 to 2 7/12 turns from the “finger-tight” position, or 1/4 to 5/12 turns from the position at which lock washer was flattened. However, the force induced in the bolt at the snug position was consistent and ranged from 7,436 to 9,295 lbs (33.16 to 41.45 kN), and differed from the value of 10,000 lbs (44.59 kN) usually associated with friction type bolts.

Mean of the maximum load induced on the bolt before failure was 12,405.80 lbs (55.32 kN) with a coefficient of variation of 20.21 percent. This was lower than the tensile load of 27,100 lbs (120.84 kN) specified by CAN B33.4 (1973) for the bolt grade 5. This difference can be attributed to the development of torsional shear stresses in the bolt shank in addition to tensile stresses during torque tensioning.

In the tests on bolt calibration by turn-of-nut method, three modes of bolt failure (see Figure 4.65 and legend of Figure 4.63) were observed and they were: torsional shear failure at the root of the thread, thread failure between the bolt and the nut, and lock washer failure by opening out resulting in misalignment of the nut and release of the bolt load.

The B33.4 grade 5 bolts are not suitable for friction type bolted connections as thread yielding occurs at 1/6 to 5/12 turns from the snug position. Note that CAN/CSA-

S16.1-94 (1995) recommends tightening the nut by 1/3 of a turn beyond the snug position for a friction type bolt of the size tested.

Variation of behavior after thread yielding is likely to be greater when a tensile load is applied to a bolt by turning the nut, as items tested are varying continuously as the bolt shank gets shortened by the turn of the nut and new portions of bolt thread are engaging the nut. Hence it is not a suitable test for comparing the behavior of bolts, but has only a limited value for determination of load induced at the snug position and the number of turns that the nut can be tightened from the snug position before threads begin to yield.

Behavior of A325 bolts under torqued tension was very different from that of B33.4 grade 5 bolts, since A325 bolt has a wider bolt head, a wider nut, and a thicker nut, while more threads in the nut engage the bolt. All these factors contribute to produce a better stress distribution in the A325 bolt.

Direct tension tests on B33.4 grade 5 bolts gave a mean tensile strength of 30.25 kips with a coefficient of variation of 8.06 percent. Those for A325 bolts were 31.46 kips and 1.32 percent respectively. Both types of bolts satisfy the minimum required tensile strength of 27.1 kips and show very consistent results as indicated by low values of coefficient of variation.

The mean tensile strength expressed in MPa based on "stress area" (Fisher and Struik, 1974) for B33.4 bolts was 899.87 MPa with a coefficient of variation of 8.27 percent. Those for A325 bolts were 943.11 MPa and 1.62 percent respectively. Both types of bolts satisfy the minimum required tensile strength of 840 MPa or 120 ksi and show very consistent results as indicated by low values of coefficient of variation.

As “stress area” accounts for the fact that the weakest section of any bolt in tension is at the threaded portion, the tensile strength based on “stress area” (Wallaert and Fisher, 1965) is a better parameter to compare the performance of two types of bolts. The results show that the two types of bolts are substantially similar in their capacity to carry tensile loads, although B33.4 bolt heads and nuts are smaller in size.

All the tested B33.4 bolts showed thread failure (see Figure 4.69), while all the tested A325 bolts showed tensile failure of bolt shank at the root of the thread. This can be attributed to the thinner nut and the lesser number of threads participating in the load transfer in the former type of bolts. The latter type of failure is more advantageous with respect to maintenance, as a bolt can be replaced easily when excessive deformation is observed since the nut does not get jammed. The former type of failure is more gradual and not sudden, but the nut invariably gets jammed. However, it is not a serious drawback as most of these tower bolts are carrying shear loads as opposed to tensile loads.

The coefficients of variation of yield strength, tensile strength, modulus of elasticity, percent of elongation, and percent of reduction in area obtained from tensile tests on angle coupons ranged from 2.38 percent to 7.89 percent indicating good consistency of the test results.

For the steel angle coupons the mean modulus of elasticity was 214.67 GPa, which compares favorably with the usual value for steel that is 200 GPa (CAN/CSA-S16.1-94, 1995).

All the results of yield strength of the steel angle coupons satisfied the minimum requirement of 300 MPa specified in CAN/CSA-G40.21-M87 (1987). The observed

mean value of 347.56 MPa, moreover, compared well with 369.6 MPa reported by Sakla et al. (1999).

All the results of tensile strength of the steel angle coupons satisfied the requirement of 450 to 620 MPa specified in CAN/CSA-G40.21-M87 (1987), while all the results of percent of elongation satisfied the minimum requirement of 20.5 specified in CAN/CSA-G40.21-M87 (1987) and CAN/CSA G40.20/G40.21-98 (1998).

Percent of reduction in area of the steel angle coupons ranged from 52.96 to 59.67 showing considerable ductility in the tested steel. It should be noted that percent of reduction in area is not a requirement for steel angles, while stress-strain diagrams (see Figure 4.70) showed a substantial plastic range and a substantial strain-hardening range indicating the tested steel was very ductile.

In the tension test on steel angle coupons, the galvanized surface peeled off at the middle of the specimen at a strain of around 0.15 mm/mm, while the mean of the ratio of tensile strength to yield strength of 1.46 was much greater than 1.05 suggested (Dhalla and Winter, 1974) to be the minimum requirement for strain-hardenability of steels suitable for structural applications.

## **CHAPTER 5**

### **MAIN CONCLUSIONS AND RECOMMENDATIONS FOR FURTHER RESEARCH**

#### **5.1 MAIN CONCLUSIONS**

The main conclusions made from this investigation are presented below.

The literature survey established that high strength friction type bolted joints have attracted considerable research effort while bearing type bolted joints have attracted only a considerably reduced research effort. Bolted joints connecting angle sections have attracted still less research effort. Previous research studies have identified the following as the variables that influence joint slip or deformation of bolted joints: (a) load applied; (b) workmanship; (c) bolt properties; (d) angle properties; (e) extent of corrosion; (f) nature of faying surfaces; (g) bolt tightening method; (h) number of bolts; (i) pitch of bolts; (j) joint length; (k) the ratio of the effective net area of steel angle or plate,  $A_{nc}$ , and the shear area of the bolts,  $A_s$ ; (l) bolt diameter; (m) the ratio of the effective net area of steel angle or plate,  $A_{nc}$ , and the gross area of the steel angle or plate,  $A_g$ ; (n) end distance and edge distance; (o) type of bolt; and (p) location of the shear planes within the bolt length.

The influence of the gap between top and bottom angle of a splice connection of a tower leg (Test Series A) on joint behavior was considered. Narrowing the gap reduces the joint deformation and increases the stiffness from an early load, which are both beneficial effects. This gap has no significant influence on tensile load carrying capacity. Increasing the gap ensures the joint deformation to reach the maximum possible at the

joint. Further, the gap cannot be eliminated as provision of a gap will simplify construction process and help tower erection within the stipulated tolerances. A gap of 3/8 inches (9.5 mm) in place of 1/4 inches (6.35 mm) is recommended for the following reasons: (i) It provides adequate space to simplify the construction process; (ii) It will make behavior of splice joint in tension and compression similar; and (iii) It helps develop maximum deformation possible at the joint, which will enable the tower to accommodate large foundation movements.

Ultimate loads of the joints were independent of the condition of construction clearance at assembly, which shows that the inherent ductility of the materials at the joint ensures that any deviators in fabrication are evened out by plastic deformation. Comparison of ultimate loads of joints of Test Series A, Test Series B, and four-bolt joints of Test Series C indicates that splice leg connection (Test Series A) carries the highest load, while the other two joints carry lesser but similar values.

Extent of slip was highest for joints with maximum construction clearance at assembly, non-existent for joints set in bearing at assembly, and between those extremes for joints with normal construction clearance at assembly. No joint was able to slip to their respective maximum possible extent of 3.18 mm or 1.59 mm due to restrictions caused by fabrication deviations, but reached slips range from 13.8 percent to 69.5 percent of the maximum possible values. In general, slip was smallest in Test Series B and highest in Test Series C.

Elastic stiffness before slip is greater than the elastic stiffness at any other stage of the loading process, because former is caused by the frictional load transfer and the mobilization of a greater effective cross sectional area to resist the load. Elastic stiffness



before slip was highest in Test Series A and lowest in Test Series C, and this is attributed to increased contact area providing better composite action of the connected members in the vicinity of the joint.

In all joints except Test Series A (tower leg splice connection), slip occurred at approximately constant load. A very small elastic stiffness was observed in Test Series A, caused by inadvertent misalignment of holes due to fabrication deviations as reported by many previous researchers (Vasarhelyi et al., 1959; Vasarhelyi and Chang, 1965; Fisher and Struik, 1974).

Observed values of slip coefficient were higher in Test Series A and C in comparison to those reported in the literature survey, but those values of Test Series B compared well with those of other researchers. The higher values are attributed to bigger washers of B33.4 grade 5 bolts.

Values of the ratio of slip to deformation reached at maximum load ranged from 0.03 to 0.44 for all the three test series. The above ratios in the work reported by Fisher et al. (1974) and Shoukry et al. (1970) for friction type bolted joints are 0.09 and 0.06 respectively. This comparison demonstrates that slip when considered in relation to deformation at maximum load is considerable in bearing type joints. Hence joint slip of bearing type joints should be separately accounted for in analytical work.

Analysis carried out on distribution of bolt loads in joints of Test Series C established that: -

- (i) Proportions of load carried by each bolt fall into a general pattern in which outer bolts carry highest loads while middle bolts carry lower loads, and this

pattern is in agreement with the findings of previous researchers (Fisher and Rumpf, 1965; Fisher and Struik, 1974);

- (ii) Proportions of load carried by each bolt become more divergent near ultimate load and this effect is also in agreement with the findings of previous researchers (Fisher and Rumpf, 1965; Fisher and Struik, 1974); and
- (iii) Percentage loads carried by intermediate and end bolts become more uniform for joints with maximum construction clearance and most divergent for joints set in bearing for three-bolt and four-bolt joints.

Bolts were tested using the Skidmore-Wilhelm Hydraulic Bolt Calibrator to determine the bolt force developed by the clamping torque of 84 ft-lbs (114.17 kN-mm), which was the value used by Manitoba Hydro on their transmission line towers. The tests gave a mean value of force developed in the bolt as 35.67 kN with a coefficient of variation of 12.34 percent showing good consistency of results.

The current practice of providing a normal construction clearance at assembly of 1/16 inches (1.59 mm) was considered satisfactory because: (i) it makes construction process easier; (ii) inadvertent misalignments due to fabrication deviations occur, which result in improved slip resistance, a stiffer joint, and no decrease in joint strength due to considerable ductility of the material; and (iii) further increase of construction clearance will increase slip and reduce the beneficial effects of (ii) above.

Mathematical expressions developed during this study for the prediction of load-deformation behavior of three types of joints are given in section 4.9. Above expressions of Test Series C can be extended to cover more bolts using the given regression equations

(see Figure 4.59). Further study, similar to Test Series C, is necessary to extend the expressions of Test Series A and B to bolt arrangements different in number of bolts.

Further simplification of the above mathematical expressions to cover all joints by one common expression was considered. This was found to require information on the influence of load-deformation expressions on overall behavior of transmission line towers.

Tests on bolt calibration by turn-of-nut method revealed that flattening of lock washers is not an event of significance because it happens at a very low load ranging from 300 to 1,530 lbs (1.34 to 6.82 kN) and well before the snug position at a number of turns varying from 1 1/2 to 2 1/6 from the “finger-tight” position.

Number of turns required to attain the snug position of the nut was variable and ranged from 1 11/12 to 2 7/12 turns from the “finger-tight” position, or 1/4 to 5/12 turns from the position at which lock washer was flattened. However, the force induced in the bolt at the snug position was consistent and ranged from 7,436 to 9,295 lbs (33.16 to 41.45 kN), and differed from the value of 10,000 lbs (44.59 kN) usually associated with friction type bolts.

The B33.4 grade 5 bolts are not suitable for friction type bolted connections as thread yielding occurs at 1/6 to 5/12 turns from the snug position. Note that CAN/CSA-S16.1-94 (1995) recommends tightening the nut by 1/3 of a turn beyond the snug a position for friction type bolt of the size tested.

Behavior of A325 bolts under torqued tension was very different from that of B33.4 grade 5 bolts, since A325 bolt has a wider bolt head, a wider nut, and a thicker nut,

while more threads in the nut engage the bolt. All these factors contribute to produce a better stress distribution in the A325 bolt.

Material properties of the bolts and the steel angles used in this study complied with the relevant standards for the material properties of bolts and steel angles used in transmission line towers.

## **5.2 RECOMMENDATIONS FOR FURTHER RESEARCH**

The following recommendations are made for further research on this field of study: -

- 1) Results of Test Series C established that the load-deformation diagrams of joints can be interpolated or extrapolated for joints similar in configuration but different in number of bolts. To enable greater usefulness for the load-deformation diagrams developed for joints in Test Series A (splice connection of a tower leg) and Test Series B (connection of a web bracing member of a tower), further research is necessary to consider similar joints with less bolts as well as more bolts. This research will help to determine the required regression equations for the governing parameters so that interpolation and extrapolation can be carried out to produce more realistic load-deformation diagrams corresponding to a wide variety of joint arrangements;
- 2) Usefulness of the mathematical expression developed in this study for the prediction of load-deformation behavior of joints needs verification. Actual deformations observed in full scale tests of transmission line towers can be used for such an

evaluation. Further research is needed on analysis of transmission line towers incorporating joint deformation into the analytical process;

- 3) Further simplification of the mathematical expressions for load-deformation relationships requires information on influence of various load-deformation relationships on overall behavior of transmission line towers. Further research on this aspect was considered to be useful; and
- 4) Benefits and shortcomings of joint slip need closer examination. Some benefits are the ability to accommodate large ground movements caused by frost heave and permafrost settlement, and ability to absorb large impact forces with reduced damage. Some shortcomings are fatigue and wind vibration. Further research on analysis of transmission line towers incorporating joint deformation can provide the required insights.

## **REFERENCES**

- Al-Bermani, F. G. A., and Kitipornchai, S. (1992), "Nonlinear Analysis of Transmission Towers", *Engineering Structures*, pp 139-151, Volume 14, No. 3.
- Al-Bermani, F. G. A., and Kitipornchai, S. (1992), "Elastoplastic Nonlinear Analysis of Flexibly Jointed Space Frames", *Journal of Structural Engineering*, American Society of Civil Engineers, pp 108-127, Volume 118, No. 1.
- Allan, R. N., and Fisher, J. W. (1968), "Bolted Joints with Oversize or Slotted Holes", *Journal of the Structural Division*, Proceedings of the American Society of Civil Engineers, pp 2061-2080, Volume 94, No. ST9.
- ASCE (1988), "Guide for Design of Steel Transmission Towers", ASCE Manuals and Reports on Engineering practice No. 52, Second Edition, ASCE Publication, U.S.A.
- ASTM A325-86a (1993), "Standard Specification for High-Strength Bolts for Structural Steel Joints", Volume 15.08, Annual Book of ASTM Standards, ASTM, Philadelphia.
- ASTM A325M-86 (1993), "Standard Specification for High-Strength Bolts for Structural Steel Joints (Metric)", Volume 15.08, Annual Book of ASTM Standards, ASTM, Philadelphia.
- ASTM A370-92 (1993), "Standard Test Methods and Definitions for Mechanical Testing of Steel Products", Volume 01.04, Annual Books of ASTM Standards, American Society of Testing Materials, Philadelphia.
- ASTM A394-92a (1993), "Standard Specification for Steel Transmission Tower Bolts. Zinc-Coated and Bare", Volume 15.08, Annual Book of ASTM Standards, ASTM, Philadelphia.

- ASTM F606-90 (1993), "Standard Test Method for Determining the Mechanical Properties of Externally and Internally Threaded Fasteners, Washers, and Rivets", Volume 15.08, Section 15, Annual Book of ASTM Standards, American Society of Testing Materials, Philadelphia.
- Bendigo, R. A., Hansen, R. M., and Rumpf, J. L. (1963), "Long Bolted Joints", Journal of the Structural Division, Proceedings of the American Society of Civil Engineers, pp 187-213, Volume 89, No. ST6.
- Brookhert, G. C., Siddiqi, I. H., and Vasarhelyi, D. D. (1968), "Surface Treatment of High-Strength Bolted Joints", Journal of the Structural Division, Proceedings of the American Society of Civil Engineers, pp 671-681, Volume 94, No. ST3.
- Brown, R. J. E. (1973), "Permafrost in Canada-Its Influence on Northern Development". University of Toronto Press, Toronto and Buffalo, U.S.A.
- CAN/CSA G40.20/G40.21-98 (1998), "General Requirements for Rolled or Welded Structural Quality Steel/ Structural Quality Steel", Canadian Standards Association, Rexdale, Ontario.
- CAN/CSA-G40.21-M87 (1987), "Structural Quality of Steels". Canadian Standards Association, Rexdale, Ontario.
- CAN/CSA-S16.1-94 (1995), "Handbook of Steel Construction", Sixth Edition, Canadian Institute of Steel Construction.
- Chen, W. F., and Zhou, S. P. (1987), "Inelastic Analysis of Steel Braced Frames with Flexible Joints", International Journal of Solids and Structures, pp 631-649, Volume 23, No. 5.

- Chesson, E. (1965), "Bolted Bridge Behavior During Erection and Service", Journal of the Structural Division, Proceedings of the American Society of Civil Engineers, pp 57-70, Volume 91, No. ST3.
- Chong, K. P., and Matlock, R. B. (1975), "Light-gage Steel Bolted Connections without Washers", Journal of the Structural Division, Proceedings of the American Society of Civil Engineers, pp 1381-1391, Volume 101, No. ST7.
- Christopher, R. J., Kulak, G. L., and Fisher, J. W. (1966), "Calibration of Alloy Steel Bolts", Journal of the Structural Division, Proceedings of the American Society of Civil Engineers, pp 19-40, Volume 92, No. ST2.
- Cox, M. G. (1972), "The Numerical Evaluation of  $\beta$ -splines", Journal of the Institute of Mathematics and Its Applications", pp 134-149, Volume 10, No. 2.
- CSA B33.4 (1973), "Galvanized Steel Tower Bolts and Nuts", Canadian Standards Association, Rexdale, Ontario.
- Dhalla, A. K., and Winter, G. (1974), "Suggested Steel Ductility Requirements", Journal of the Structural Division, Proceedings of the American Society of Civil Engineers, pp 445-462, Volume 100, No. ST2.
- Eaves, L. D. (1978), "Influence of Thread Lubrication on the Behavior of High Strength Bolts", M.Sc. Eng. Thesis, Department of Civil Engineering, The University of Texas, Austin, Texas.
- Elgaaly, M., Dagher, H., and Davids, W. (1991), "Behavior of Single-Angle-Compression Members", Journal of Structural Engineering, American Society of Civil Engineers, pp 3720-3741, Volume 117, No. 12.



- Fisher, J. W. (1965), "Behavior of Fasteners and Plates with Holes", *Journal of the Structural Division, Proceedings of the American Society of Civil Engineers*, pp 265-286, Volume 91, No. ST6.
- Fisher, J. W., and Beedle, L. S. (1965), "Criteria for Designing Bearing-Type Bolted Joints", *Journal of the Structural Division, Proceedings of the American Society of Civil Engineers*, pp 129-154, Volume 91, No. ST5.
- Fisher, J. W., and Kulak, G. L. (1968), "Tests of Bolted Butt Splices", *Journal of the Structural Division, Proceedings of the American Society of Civil Engineers*, pp 2609-2619, Volume 94, No. ST11.
- Fisher, J. W., and Rumpf, J. L. (1965), "Analysis of Bolted Butt Splices", *Journal of the Structural Division, Proceedings of the American Society of Civil Engineers*, pp 181-203, Volume 91, No. ST5.
- Fisher, J. W., and Struik, J. H. A. (1974), "Guide to Design Criteria for Bolted and Riveted Joints", John Wiley and Sons, Inc., U.S.A.
- Frye, M. J., and Morris, G. A. (1974), "Analysis of Flexibly connected Steel Frames", *Canadian Journal of Civil Engineering*, pp 280-291, Volume 2.
- Gill, F. L., and Hansen, R. M. (1966), "Brittleness in High Strength Bolts", *Journal of the Structural Division, Proceedings of the American Society of Civil Engineers*, pp 89-100, Volume 92, No. ST1.
- Goel, A. P. (1994), "Fatigue Problems in Power Transmission Lines", *Canadian Civil Engineer*, pp 6-7, Volume 11, No. 2.

- Goldberg, J. E., and Richard, R. M. (1963), "Analysis of Nonlinear Structures", Journal of the Structural Division, Proceedings of the American Society of Civil Engineers, pp 333-351, Volume 89, No. ST4.
- Jones, S. W., Kirby, P. A., and Nethercot, D. A. (1982), "Columns with Semirigid Joints", Journal of the Structural Division, Proceedings of the American Society of Civil Engineers, pp 361-372, Volume 108, No. ST2.
- Kennedy, D. J. L. (1972), "High Strength Bolted Galvanized Joints", Journal of the Structural Division, Proceedings of the American Society of Civil Engineers, pp 2723-2738, Volume 98, No. ST12.
- Kennedy, J. B., and Sinclair, G. R. (1969), "Ultimate Capacity of Single Bolted Angle Connections", Journal of the Structural Division, Proceedings of the American Society of Civil Engineers, pp 1645-1660, Volume 95, No. ST8.
- Kitipornchai, S., Al-Bermani, F. G. A., and Peyrot, A. H. (1994), "Effect of Bolt Slippage on Ultimate Behavior of Lattice Structures", Journal of Structural Engineering, American Society of Civil Engineers, pp 2281-2287, Volume 120, No. 8.
- Knight, G. M. S., and Santhakumer, A. R. (1993), "Joint Effects on Behavior of Transmission Towers", Journal of Structural Engineering, American Society of Civil Engineers, pp 698-712, Volume 119, No. 3.
- Kormanik, R., and Fisher, J. W. (1967), "Bearing-Type Bolted Hybrid Joints", Journal of the Structural Division, Proceedings of the American Society of Civil Engineers, pp 363-382, Volume 93, No. ST5.

- Kravitz, R. A., and Samuelson, A. J. (1969), "Tower Designs for AEP 756KV Project",  
Journal of the Power Division, Proceedings of the American Society of Civil  
Engineers, pp 305-319, Volume 95, No. PO2.
- Kulak, G. L., and Fisher, J. W. (1968), "A514 Steel Joints Fastened by A490 Bolts",  
Journal of the Structural Division, Proceedings of the American Society of Civil  
Engineers, pp 2303-2323, Volume 94, No. ST10.
- Kulak, G. L., and Wu, E. Y. (1997), "Shear Lag in Bolted Angle Tension Members",  
Journal of Structural Engineering, American Society of Civil Engineers, pp 1144-  
1152, Volume 123, No. 9.
- Kulak, G. L., Fisher, J. W., and Struik, J. H. A. (1987), "Guide to Design Criteria for  
Bolted and Riveted Joints", Second Edition, John Wiley and Sons, Inc., Canada.
- Lobb, V., and Stoller, F. (1971), "Bolted Joints Under Sustained Loading", Journal of the  
Structural Division, Proceedings of the American Society of Civil Engineers, pp 905-  
933, Volume 97, No. ST3.
- Lui, E. M., and Chen, W. F. (1988), "Analysis and Behavior of Flexibly-Jointed Frames",  
Engineering Structures, pp 107-118, Volume 8, No. 2, April 1986.
- Madugula, M. K. S., and Mohan, S., "Angle in Eccentric Tension", Journal of Structural  
Engineering, American Society of Civil Engineers, pp 2387-2396, Volume 114, No.  
10.
- Marjerrison, M. (1968), "Electric Transmission Tower Design", Journal of the Structural  
Division, Proceedings of the American Society of Civil Engineers, pp 1-23, Volume  
94, No. PO1.

- Petersen, W. O. (1962), "Design of EHV Steel Tower Transmission Lines", Journal of the Structural Division, Proceedings of the American Society of Civil Engineers, pp 39-65, Volume 88, No. PO1.
- Pickford, J. H. (1981), "An Introduction to the Design and Behavior of Bolted Joints", Marcel Dekker, Inc., New York and Basel, U.S.A.
- Polyzois, D., and Frank, K. H. (1986), "Effect of Overspray and Incomplete Masking of Faying Surfaces on the Slip Resistance of Bolted Connections" Engineering Journal of the American Institute of Steel Construction, pp 65-69, Volume 23, No. 2, 2<sup>nd</sup> Quarter.
- Polyzois, D., and Yura, J. A. (1985), "Effect of Burrs on Bolted Friction Connections" Engineering Journal of the American Institute of Steel Construction, pp 139-142, Volume 22, No. 3, 3<sup>rd</sup> Quarter.
- Romsted, K. M., and Subramaniam, C. V. (1970), "Analysis of Frames with Partial Connection Rigidity", Journal of the Structural Division, Proceedings of the American Society of Civil Engineers, pp 2283-2300, Volume 96, No. ST11.
- Rumpf, J. L., and Fisher, J. W. (1963), "Calibration A325 Bolts", Journal of the Structural Division, Proceedings of the American Society of Civil Engineers, pp 215-234, Volume 89, No. ST6.
- SAE J429-August 83 (1994), "Mechanical and Material Requirements for Externally Threaded Fasteners", Volume 1, 1994 SAE Handbook, Society of Automotive Engineers, Inc., U.S.A.

- Sakla, S. S. S., Wahba, Y. M. F., and Madugula, M. K. S. (1999), "Spliced Axially-Loaded Single-Angle Members in Compression", *Engineering Journal of American Institute of Steel Construction*, pp 4-11, Volume 36, No. 1, 1<sup>st</sup> Quarter.
- Shoukry, Z., and Haisch, W. T. (1970), "Bolted Connections with Varied Hole Diameters", *Journal of the Structural Division, Proceedings of the American Society of Civil Engineers*, pp 1105-1118, Volume 96, No. ST6.
- Sterling, G. H., and Fisher, J. W. (1966), "A440 Steel Joints Connected by A490 Bolts". *Journal of the Structural Division, Proceedings of the American Society of Civil Engineers*, pp 101-118, Volume 92, No. ST3.
- Sterling, G. H., Troup, E. W. J., Chesson, E., and Fisher, J. W. (1965), "Calibration Tests of A490 High-Strength Bolts", *Journal of the Structural Division, Proceedings of the American Society of Civil Engineers*, pp 279-298, Volume 91, No. ST5.
- Subramaniam, A., Rajapakse, N., Polyzois, D., and Yue, B. (1999), "Low-Cycle Fatigue Behavior of Copper Zinc Aluminum Shape Memory Alloys", "Smart Structures", (J. Holnicki-Szule and J. Rodellar (Eds)), pp 337-344, Kluwer Academic Publishers.
- Temple, M. C., and Sakla, S. S. S. (1996), "Considerations for the Design of Single-Angle Compression Members Attached by One Leg", *Canadian Journal of Civil Engineering*, pp 287-294, Volume 23, No. 1.
- Vasarhelyi, D. D., and Chang, W. N. (1965), "Misalignment in Bolted Joints", *Journal of the Structural Division, Proceedings of the American Society of Civil Engineers*, pp 1-15, Volume 91, No. ST4.

- Vasarhelyi, D. D., and Chen, C. (1967), "Bolted Joints with Plates of Different Thickness", *Journal of the Structural Division, Proceedings of the American Society of Civil Engineers*, pp 201-211, Volume 93, No. ST6.
- Vasarhelyi, D. D., Beano, S. Y. Madison, R. B., Lu, Z., and Vasishth, U. C. (1959), "Effects of Fabrication Techniques on Bolted Joints", *Journal of the Structural Division, Proceedings of the American Society of Civil Engineers*, pp 71-116, Volume 85, No. ST3.
- Wallaert, J. J., and Fisher, J. W. (1965), "Shear Strength of High-Strength Bolts", *Journal of the Structural Division, Proceedings of the American Society of Civil Engineers*, pp 99-125, Volume 91, No. ST3.
- Winter, G. (1956), "Tests on Bolted Connection in Light Gage Steel", *Journal of the Structural Division, Proceedings of the American Society of Civil Engineers*, pp 920-1 to 920-21, Volume 82, No. ST2.
- Yura, J. A., and Frank, K. H. (1985), "Testing Method to Determine the Slip Coefficient for Coatings Used in Bolted Joints" *Engineering Journal of the American Institute of Steel Construction*, pp 151-155, Volume 22, No. 3, 3<sup>rd</sup> Quarter.
- Yura, J. A., Frank, K. H., and Cayes, L. (1981), "Friction-Type Bolted Connections with A588 Weathering Steel", Report NO. FHWA/RD-81/147, U.S. Department of Transportation, Federal Highway Administration, Office of Research and Development, Structures and Applied Mechanics Division, Washington, D.C. 20590.
- Zwernemen, F. J., and Saleh, Y. (1996), "The Effect of Burrs on the Shear Capacity of Bearing Connections", *Engineering Journal of the American Institute of Steel Construction*, pp 3-6, Volume 33, No. 1, 1<sup>st</sup> Quarter.

# **APPENDIX A - TABLES**

**Table 3.1 Specimen numbers of Test Series A, B, and C**

Specimen	Test Series		Construction clearance (in.)	Remark
AM1, AM2, AM3 AN1, AN2, AN3 AB1, AB2, AB3	A		1/8 (Maximum) 1/16 (Normal) 0 (Bearing)	
BM1, BM2, BM3 BN1, BN2, BN3 BB1, BB2, BB3	B		1/8 (Maximum) 1/16 (Normal) 0 (Bearing)	
C1M1, C1M2, C1M3 C1N1, C1N2, C1N3 C1B1, C1B2, C1B3	C	C1	1/8 (Maximum) 1/16 (Normal) 0 (Bearing)	Single bolted joint
C2M1, C2M2, C2M3 C2N1, C2N2, C2N3 C2B1, C2B2, C2B3	C	C2	1/8 (Maximum) 1/16 (Normal) 0 (Bearing)	Two-bolt joint
C3M1, C3M2, C3M3 C3N1, C3N2, C3N3 C3B1, C3B2, C3B3	C	C3	1/8 (Maximum) 1/16 (Normal) 0 (Bearing)	Three-bolt joint
C4M1, C4M2, C4M3 C4N1, C4N2, C4N3 C4B1, C4B2, C4B3	C	C4	1/8 (Maximum) 1/16 (Normal) 0 (Bearing)	Four-bolt joint



**Table 4.1 Important stages of load in specimens of Test Series A**

Bolt Arrangement	Load at commencement of slip		Load at end of slip		Load at the end of load transfer through splice angle		Load at onset of plasticity		Maximum load		Load at termination of the test	
	Joint Load (kN)	Load/Bolt (kN)	Joint Load (kN)	Load/Bolt (kN)	Joint Load (kN)	Load/Bolt (kN)	Joint Load (kN)	Load/Bolt (kN)	Joint Load (kN)	Load/Bolt (kN)	Joint Load (kN)	Load/Bolt (kN)
AM1	36.59	9.15	115.61	28.90	230.65	57.66	294.80	73.70	305.35	76.34	228.44	57.11
AM2	48.39	12.10	117.93	29.48	216.65	54.16	283.92	70.98	299.24	74.81	254.68	63.67
AM3	48.79	12.20	119.77	29.94	237.52	59.38	274.67	68.67	290.23	72.56	247.58	61.90
AN1	41.19	10.30	90.51	22.63	186.96	46.74	301.55	75.39	308.40	77.10	267.01	66.75
AN2	43.77	10.94	82.39	20.60	154.86	38.72	274.20	68.55	299.79	74.95	266.42	66.61
AN3	40.93	10.23	65.58	16.40	231.68	57.92	279.41	69.85	298.12	74.53	258.04	64.51
AB1	-	-	-	-	242.88	60.72	279.78	69.95	297.29	74.32	233.30	58.33
AB2	-	-	-	-	220.72	55.18	286.39	71.60	297.05	74.26	263.48	65.87
AB3	-	-	77.90	19.48	225.69	56.42	291.64	72.91	301.69	75.42	256.85	64.21
<b>Mean</b>	43.28	10.82	-	24.66	216.40	54.10	285.15	71.29	299.68	74.92	252.87	63.22
<b>C.O.V. (%)</b>	10.90	10.90	-	22.81	13.01	13.01	3.28	3.28	1.74	1.74	5.50	5.50

\* The result is omitted due to inaccuracies in the shop production of bolt holes at specified spacing and location.

( ) Mean value

**Table 4.2 Important parameters that define the load versus joint deformation response of specimens of Test Series A**

Bolt Arrangement	P (mm)	Q (mm)	R (mm)	S (mm)	T (mm)	U (mm)	$\theta_1$ (kN/mm)	$\theta_2$ (kN/mm)	$\theta_3$ (kN/mm)	$\theta_4$ (kN/mm)	$\theta_5$ (kN/mm)
AM1	0.31	3.73	2.97	0.73	0.36	2.29	283.17	24.29	38.73	87.88	141.87
AM2	0.29	3.36	2.58	0.68	0.40	1.44	325.13	20.80	38.26	98.93	180.62
AM3	0.32	3.39	2.76	0.39	0.40	0.90	374.63	21.17	42.66	95.26	194.86
AN1	0.08	2.58	2.12	1.32	0.13	0.73	222.49	17.38	45.50	86.81	222.49
AN2	0.47	1.33	1.94	1.32	0.52	1.50	176.29	24.43	37.37	90.41	129.56
AN3	0.36	1.57	3.61	0.67	0.51	0.62	206.75	17.88	46.01	71.24	151.84
AB1	0.29	0.00	2.96	0.40	0.41	1.08	294.25	-	59.09	92.25	190.39
AB2	0.29	0.00	3.03	0.77	0.26	0.44	247.80	-	39.21	85.28	216.73
AB3	0.24	1.29*	4.61	0.92	0.27	0.91	240.51	16.57*	46.04	70.91	131.63
<b>Mean</b>	0.29	-	2.95	0.80	0.36	1.10	263.45	20.99	43.65	86.55	173.33
<b>C.O.V. (%)</b>	35.01	-	26.98	42.40	34.48	51.49	23.54	14.37	15.51	11.25	20.61

\* The result is omitted due to inaccuracies in the shop production of bolt holes at specified spacings and locations.

( ) Mean value

**Note:** Symbols in the code (P, Q, R, etc.) are illustrated in Figure 4.1.

**Table 4.3 Slip coefficient during frictional load transfer of specimens of Test Series A**

<b>Bolt Arrangement</b>	<b>Slip Coefficient</b>
AM1	0.26
AM2	0.34
AM3	0.34
AN1	0.29
AN2	0.31
AN3	0.29
AB1	-
AB2	-
AB3	-
<b>Mean</b>	<b>0.31</b>
<b>C.O.V. (%)</b>	<b>7.99</b>

**Table 4.4 Important stages of load in specimens of Test Series B**

Bolt Arrangement	Load at Slip		Load at onset of Plasticity		Maximum Load	
	Joint Load (kN)	Load/Bolt* (kN)	Joint Load (kN)	Load/Bolt* (kN)	Joint Load (kN)	Load/Bolt* (kN)
BM1	64.31**	16.08**	147.60	36.90	204.28	51.07
BM2	22.06	5.52	138.80	34.70	203.44	50.86
BM3	27.10	6.78	135.36	33.84	205.47	51.37
BN1	23.78	5.95	132.87	33.22	207.71	51.93
BN2	21.32	5.33	143.55	35.89	198.17	49.54
BN3	25.47	6.37	130.34	32.59	210.06	52.52
BB1	-	-	134.86	33.72	203.41	50.85
BB2	-	-	111.13	27.78	211.78	52.95
BB3	-	-	115.06	28.77	201.37	50.34
<b>Mean</b>	23.95	5.99	132.17	33.04	205.08	51.27
<b>C.O.V. (%)</b>	9.96	9.96	9.14	9.14	2.07	2.07

\* Equivalent single shear load per bolt at slip.

\*\* As this was the first specimen to be tested, it was repeatedly mounted and dismantled from the end attachments of the testing machine to get it correctly in position and in the process either it has got jammed increasing the clamping force or the alignment of individual angles may have changed to give a higher than normal load at slip. Hence this value was not considered to be reliable.

**Table 4.5 Important stages of deformation and elastic stiffness in specimens of Test Series B**

Bolt Arrangement	Extent of slip (mm)	Deformation between end of slip and onset of Plasticity (mm)	Deformation between onset of Plasticity and Maximum load (mm)	Deformation from Maximum load to complete Failure (mm)	(1) Elastic Stiffness before commencement of slip (KN/mm)	(2) Elastic Stiffness after end of slip (KN/mm)	(1)/(2)
BM1	0.56 } (060)	1.19	3.33	9.36	190.25	64.44	2.95
BM2		2.65	3.96	7.86	187.19	45.72	4.09
BM3		2.06	3.85	8.40	216.49	50.91	4.25
BN1	0.21 } (220)	2.32	3.94	9.87	243.09	61.17	3.97
BN2		2.53	3.12	6.93	209.85	65.13	3.22
BN3		2.40	4.57	5.52	212.50	62.58	3.40
BB1	0.00	1.84	3.77	9.31	217.23	65.72	3.31
BB2	0.00	1.78	5.20	9.10	216.15	51.61	4.19
BB3	0.00	2.02	4.14	8.54	209.70	57.50	3.65
<b>Mean</b>	-	2.09	3.99	8.32	211.38	58.31	3.67
<b>C.O.V. (%)</b>	-	21.62	15.58	16.52	7.71	12.49	12.94

\* As this was the first specimen to be tested, it was repeatedly mounted and dismounted from the end attachments of the testing machine to get it correctly in position and in the process the clearance between bolt and bolt hole may have reduced from maximum to intermediate clearance. Hence this value was not considered to be reliable.

( ) Mean value

**Table 4.6 Slip coefficient during friction load transfer of specimens of Test Series B**

<b>Bolt Arrangement</b>	<b>Slip Coefficient</b>
BM1	0.45 <sup>*</sup>
BM2	0.15
BM3	0.19
BN1	0.17
BN2	0.15
BN3	0.18
BB1	-
BB2	-
BB3	-
<b>Mean</b>	<b>0.17</b>
<b>C.O.V. (%)</b>	<b>9.96</b>

\* As this was the first specimen to be tested, it was repeatedly mounted and dismounted from the end attachments of the testing machine to get it correctly in position and in the process either it has got jammed increasing the clamping force or the alignment of individual angles may have changed to give a higher than normal slip coefficient . Hence this value was not considered to be reliable.

**Table 4.7 Important stages of load in Test Series C (1 of 2 pages)**

Bolt Arrangement	Load at commencement of Slip		Load at onset of Plasticity		Maximum Load		Remarks
	Joint Load (kN)	Load/Bolt (kN)	Joint Load (kN)	Load/Bolt (kN)	Joint Load (kN)	Load/Bolt (kN)	
C1M1	9.98	9.98	76.15	76.15	107.69	107.69	-Stopped the test prematurely due to mistake in identifying onset of yielding as onset of failure. Re-tested with fixed end support conditions later, and specimen failed by bolt shearing apart.  -Tested to an intermediate load till testing machine got locked. Re-tested after adjusting the testing machine.
C1M2	8.10	8.10	61.48	61.48	104.73	104.73	
C1M3	9.94	9.94	67.55	67.55	112.36	112.36	
C1N1	9.23	9.23	65.64	65.64	100.49	100.49	
C1N2	9.84	9.84	63.43	63.43	113.60	113.60	
C1N3	8.63	8.63	70.05	70.05	111.70	111.70	
C1B1	-	-	60.77	60.77	104.85	104.85	
C1B2	-	-	55.16	55.16	108.39	108.39	
C1B3	-	-	-	-	106.20	106.20	
<b>Mean</b>	9.29	9.29	65.03	65.03	107.78	107.78	
<b>C.O.V. (%)</b>	8.42	8.42	9.83	9.83	3.94	3.94	
C2M1	25.27	12.64	102.64	51.32	173.73	86.87	
C2M2	22.26	11.13	113.22	56.61	167.47	83.74	
C2M3	23.61	11.81	106.18	53.09	154.25	77.13	
C2N1	19.61	9.81	80.15	40.08	156.41	78.21	
C2N2	16.04	8.02	80.89	40.45	147.51	73.76	
C2N3	14.04	7.02	92.44	46.22	149.95	74.98	
C2B1	-	-	104.68	52.34	148.82	74.41	
C2B2	-	-	100.04	50.02	152.24	76.12	
C2B3	-	-	97.32	48.66	169.01	84.51	
<b>Mean</b>	20.14	10.07	97.51	48.75	157.71	78.86	
<b>C.O.V. (%)</b>	21.89	21.89	11.52	11.52	6.21	6.21	

**Table 4.7 (Continued) Important stages of load in Test Series C (2 of 2 pages)**

Bolt Arrangement	Load at commencement of Slip		Load at onset of Plasticity		Maximum Load		Remarks
	Joint Load (kN)	Load/Bolt (kN)	Joint Load (kN)	Load/Bolt (kN)	Joint Load (kN)	Load/Bolt (kN)	
C3M1	31.48	10.49	122.56	40.85	141.89	47.30	-Angle buckled due to considerable movement due to pinned supports. Therefore, in later tests, fixed end support conditions with the limited rotation to take up any unevenness at angle ends were used.
C3M2	28.78	9.59	153.99	51.33	205.65	68.55	
C3M3	31.29	10.43	171.90	57.30	215.89	71.96	
C3N1	29.95	9.98	150.51	50.17	207.76	69.25	
C3N2	27.86	9.29	157.95	52.65	209.23	69.74	
C3N3	26.34	8.78	149.28	49.76	218.20	72.73	
C3B1	-	-	146.06	48.69	209.54	69.85	
C3B2	-	-	152.42	50.81	213.53	71.18	
C3B3	-	-	170.98	56.99	217.90	72.63	
<b>Mean</b>	29.28	9.76	152.85	50.95	204.40	68.13	
<b>C.O.V. (%)</b>	6.87	6.87	9.54	9.54	11.68	11.68	
C4M1	-	-	-	-	195.40	48.85	-Test abandoned due to accidental loading of the specimen instantaneously up to failure.
C4M2	48.77	12.19	167.47	41.87	206.86	51.72	
C4M3	54.48	13.62	167.95	41.99	205.48	51.37	
C4N1	43.55	10.89	157.28	39.32	209.68	52.42	
C4N2	47.23	11.81	163.74	40.94	210.64	52.66	
C4N3	40.71	10.18	170.19	42.55	212.51	53.13	
C4B1	-	-	173.74	43.44	209.42	52.36	
C4B2	-	-	174.32	43.58	208.54	52.14	
C4B3	-	-	170.95	42.74	209.40	52.35	
<b>Mean</b>	46.95	11.74	168.21	42.05	207.55	51.89	
<b>C.O.V. (%)</b>	11.20	11.20	3.33	3.33	2.40	2.40	



**Table 4.8 Important stages of deformation in Test Series C (1 of 2 pages)**

<b>Bolt Arrangement</b>	<b>Extent of Slip in mm (mean)</b>	<b>Deformation between end of Slip and onset of Plasticity (mm)</b>	<b>Deformation between onset of Plasticity and Maximum load (mm)</b>	<b>Deformation from Max.Load to 10% below Max.Load in mm (mean)</b>	<b>Remarks</b>
C1M1	2.27	1.93	-	-	-Stopped the test prematurely due to mistake in identifying onset of yielding as onset of failure. Re-tested with fixed end support conditions later, and specimen failed by bolt shearing apart.
C1M2	2.02	2.17	5.92	-	
C1M3	2.56	3.00	7.36	-	
C1N1	0.72	3.03	4.48	1.19	
C1N2	1.40	2.87	6.89	1.71	
C1N3	0.83	3.30	6.17	1.43	
C1B1	0.00	3.08	5.31	-	
C1B2	0.00	2.55	6.14	-	
C1B3	0.00	-	-	-	
<b>Mean</b>	-	2.74	6.04	-	-Tested to an intermediate load till testing machine got locked. Re-tested after adjusting the testing machine.
<b>C.O.V. (%)</b>	-	17.52	15.82	-	
C2M1	2.64	1.35	3.38	0.80	
C2M2	2.12	1.82	2.87	1.00	
C2M3	2.30	1.77	2.19	0.53	
C2N1	1.38	1.26	2.80	0.60	
C2N2	0.69	1.34	2.33	0.57	
C2N3	1.03	1.62	2.01	0.56	
C2B1	-	2.45	1.89	0.61	
C2B2	-	1.81	2.02	0.66	
C2B3	-	2.11	3.44	0.66	
<b>Mean</b>	-	1.73	2.55	-	
<b>C.O.V. (%)</b>	-	22.52	23.35	-	

Table 4.8 (Continued) Important stages of deformation in Test Series C (2 of 2 pages)

Bolt Arrangement	Extent of Slip in mm (mean)	Deformation between end of Slip and onset of Plasticity (mm)	Deformation between onset of Plasticity and Maximum load (mm)	Deformation from Max.Load to 10% below Max.Load in mm (mean)	Remarks
C3M1	2.22	1.59	0.70*	1.23	-Angle buckled due to considerable movement due to pinned supports. Therefore, in later tests, fixed end support conditions with the limited rotation to take up any unevenness at angle ends were used.
C3M2	2.05	2.43	1.86	1.51	
C3M3	1.89	2.74	1.99	0.89	
C3N1	0.52	2.11	2.37	0.79	
C3N2	0.42	2.42	2.24	1.10	
C3N3	0.78	2.61	2.84	2.37	
C3B1	-	2.25	2.30	1.07	
C3B2	-	2.20	2.23	1.39	
C3B3	-	3.26	1.57	2.37	
<b>Mean</b>	-	2.40	2.18	-	
<b>C.O.V. (%)</b>	-	19.22	17.40	-	
C4M1	-	-	-	-	-Test abandoned due to accidental loading of the specimen instantaneously up to failure.
C4M2	2.14	1.67	1.09	4.24	
C4M3	2.11	1.52	0.91	2.26	
C4N1	0.59	1.80	1.78	2.43	
C4N2	0.74	1.86	1.28	3.15	
C4N3	1.14	1.60	1.21	3.69	
C4B1	-	2.14	0.98	2.50	
C4B2	-	2.36	1.03	1.63	
C4B3	-	1.88	1.02	2.18	
<b>Mean</b>	-	1.85	1.16	-	
<b>C.O.V. (%)</b>	-	15.14	23.84	-	

\* Omitted from mean and C.O.V. calculations, as this deformation is more sensitive to changed support conditions.

**Table 4.9 Important elastic stiffness values in Test Series C (1 of 2 pages)**

<b>Bolt Arrangement</b>	<b>(1) Elastic Stiffness before commencement of Slip (kN/mm)</b>	<b>(2) Elastic Stiffness after slip (kN/mm)</b>	<b>(1)/(2)</b>	<b>Elastic Stiffness during unloading (kN/mm)</b>	<b>Remarks</b>
C1M1	35.78	34.78	1.03	-	-Stopped the test prematurely due to mistake in identifying onset of yielding as onset of failure. Re-tested with fixed end support conditions later, and specimen failed by bolt shearing apart.
C1M2	35.20	32.90	1.07	-	
C1M3	21.47	19.80	1.08	-	
C1N1	22.28	20.82	1.07	-	
C1N2	24.98	19.51	1.28	-	
C1N3	25.02	22.07	1.13	-	
C1B1	27.29	19.70	-	-	
C1B2	28.09	20.39	-	-	
C1B3	-	-	-	-	
<b>Mean</b>	27.51	23.75	1.11	-	-Tested to an intermediate load till testing machine got locked. Re-tested after adjusting the testing machine.
<b>C.O.V. (%)</b>	19.64	26.54	8.05	-	
C2M1	108.55	65.07	1.67	-	
C2M2	66.27	47.14	1.41	-	
C2M3	90.32	56.38	1.60	-	
C2N1	62.15	54.67	1.14	-	
C2N2	77.37	56.07	1.38	-	
C2N3	86.64	62.05	1.40	-	
C2B1	87.14	43.69	-	-	
C2B2	97.26	54.46	-	-	
C2B3	87.60	44.78	-	-	
<b>Mean</b>	84.81	53.81	1.43	-	
<b>C.O.V. (%)</b>	17.08	13.72	13.12	-	

**Table 4.9 (Continued) Important elastic stiffness values in Test Series C (2 of 2 pages)**

<b>Bolt Arrangement</b>	<b>(1) Elastic Stiffness before commencement of Slip (kN/mm)</b>	<b>(2) Elastic Stiffness after slip (kN/mm)</b>	<b>(1)/(2)</b>	<b>Elastic Stiffness during unloading (kN/mm)</b>	<b>Remarks</b>
C3M1	108.27	62.11	1.74	-	-Angle buckled due to considerable movement due to pinned supports. Therefore, in later tests, fixed end support conditions with the limited rotation to take up any unevenness at angle ends were used.
C3M2	96.28	60.89	1.58	-	
C3M3	84.18	51.81	1.62	-	
C3N1	85.88	55.37	1.55	-	
C3N2	145.01	54.49	2.66	144.58	
C3N3	145.24	55.65	2.61	168.56	
C3B1	142.97	55.52	-	-	
C3B2	135.18	60.48	-	-	
C3B3	82.24	49.38	-	-	
<b>Mean</b>	113.92	56.19	1.96	-	
<b>C.O.V. (%)</b>	24.56	7.59	26.82	-	
C4M1	-	-	-	-	-Test abandoned due to accidental loading of the specimen instantaneously up to failure.
C4M2	107.16	77.17	1.39	84.66	
C4M3	97.24	83.29	1.17	77.11	
C4N1	130.73	63.03	2.07	86.07	
C4N2	163.36	66.28	2.46	106.88	
C4N3	147.13	84.17	1.75	66.31	
C4B1	137.51	82.69	-	198.79	
C4B2	165.34	74.71	-	173.18	
C4B3	163.12	91.17	-	153.30	
<b>Mean</b>	138.95	77.81	1.77	-	
<b>C.O.V. (%)</b>	18.77	12.23	29.43	-	

**Table 4.10 Slip coefficient values in Test Series C (1 of 2 pages)**

<b>Bolt Arrangement</b>	<b>Slip Coefficient</b>	<b>Remarks</b>
C1M1 C1M2 C1M3 C1N1 C1N2 C1N3 C1B1 C1B2 C1B3	0.28 0.23 0.28 0.26 0.28 0.24 - - -	-Stopped the test prematurely due to mistake in identifying onset of yielding as onset of failure. Re-tested with fixed end support conditions later, and specimen failed by bolt shearing apart.  -Tested to an intermediate load till testing machine got locked. Re-tested after adjusting the testing machine.
<b>Mean</b> <b>C.O.V. (%)</b>	0.26 8.42	
C2M1 C2M2 C2M3 C2N1 C2N2 C2N3 C2B1 C2B2 C2B3	0.35 0.31 0.33 0.27 0.22 0.20 - - -	
<b>Mean</b> <b>C.O.V. (%)</b>	0.28 21.89	
C3M1 C3M2 C3M3 C3N1 C3N2 C3N3 C3B1 C3B2 C3B3	0.29 0.27 0.29 0.28 0.26 0.25 - - -	-Angle buckled due to considerable movement due to pinned supports. Therefore, in later tests, fixed end support conditions with the limited rotation to take up any unevenness at angle ends were used.
<b>Mean</b> <b>C.O.V. (%)</b>	0.27 6.87	

**Table 4.10 (Continued) Slip coefficient values in Test Series C  
(2 of 2 pages)**

<b>Bolt Arrangement</b>	<b>Slip Coefficient</b>	<b>Remarks</b>
C4M1 C4M2 C4M3 C4N1 C4N2 C4N3 C4B1 C4B2 C4B3	- 0.34 0.38 0.31 0.33 0.29 - - -	-Test abandoned due to accidental loading of the specimen instantaneously up to failure.
<b>Mean</b> <b>C.O.V. (%)</b>	0.33 11.20	

**Table 4.11 Means of load values at various important stages of the loading process**

Description	Test Series A	Test Series B	Test Series C	
Load at commencement of slip (kN)	43.28	23.95	1-bolt joint: 2-bolt joint: 3-bolt joint: 4-bolt joint:	9.29 20.14 29.28 46.95
Load at the end of slip (kN)	Maximum Clearance: 117.77 Normal Clearance: 79.49	23.95	1-bolt joint: 2-bolt joint: 3-bolt joint: 4-bolt joint:	9.29 20.14 29.28 46.95
Load at the end of load transfer through splice angle only (kN)	216.40	-	1-bolt joint: 2-bolt joint: 3-bolt joint: 4-bolt joint:	- - - -
Load at onset of plasticity (kN)	285.15	132.17	1-bolt joint: 2-bolt joint: 3-bolt joint: 4-bolt joint:	65.03 97.51 152.85 168.21
Maximum load (kN)	299.68	205.08	1-bolt joint: 2-bolt joint: 3-bolt joint: 4-bolt joint:	107.78 157.71 204.40 207.55

- Not applicable

**Table 4.12 Means of slip or deformation values at various important stages of the loading process (1 of 2 pages)**

Description		Test Series A	Test Series B	Test Series C	
Deformation under frictional load transfer (mm)		0.29	0.11	1-bolt joint: 0.34 2-bolt joint: 0.24 3-bolt joint: 0.26 4-bolt joint: 0.34	(0.30)
Slip (mm)	Maximum Clearance	3.49*	0.90	1-bolt joint: 2.28 2-bolt joint: 2.35 3-bolt joint: 2.05 4-bolt joint: 2.13	(2.20)
	Normal Clearance	1.83*	0.22	1-bolt joint: 0.98 2-bolt joint: 1.03 3-bolt joint: 0.57 4-bolt joint: 0.82	(0.85)
	In Bearing	-	-	1-bolt joint: - 2-bolt joint: - 3-bolt joint: - 4-bolt joint: -	
Deformation during load transfer by splice angle only (mm)		2.95	-	1-bolt joint: - 2-bolt joint: - 3-bolt joint: - 4-bolt joint: -	
Deformation during load transfer by direct contact of angles and the splice angle (mm)		0.80	-	1-bolt joint: - 2-bolt joint: - 3-bolt joint: - 4-bolt joint: -	
Deformation during load transfer by bolt bearing (mm)		-	2.09	1-bolt joint: 2.74 2-bolt joint: 1.73 3-bolt joint: 2.40 4-bolt joint: 1.85	(2.18)
Deformation between onset of plastic and maximum load (mm)		0.36	3.99	1-bolt joint: 6.04 2-bolt joint: 2.55 3-bolt joint: 2.18 4-bolt joint: 1.16	(2.98)

- Not applicable

( ) Mean value

\* Slip equivalent to slip of two separate joints



**Table 4.12 (Continued) Means of slip or deformation values at various important stages of the loading process (2 of 2 pages)**

Description		Test Series A	Test Series B	Test Series C	
Deformation reached at maximum load (mm)	Maximum Clearance	7.89	7.09	1-bolt joint: 11.40 2-bolt joint: 6.87 3-bolt joint: 6.89 4-bolt joint: 5.48	(7.66)
	Normal Clearance	6.23	6.41	1-bolt joint: 10.10 2-bolt joint: 5.55 3-bolt joint: 5.41 4-bolt joint: 4.17	(6.31)
	In Bearing	4.40	6.19	1-bolt joint: 9.12 2-bolt joint: 4.52 3-bolt joint: 4.84 4-bolt joint: 3.35	(5.46)

- Not applicable

( ) Mean value

**Table 4.13 Means of elastic stiffness values at various important stages of the loading process**

<b>Description</b>	<b>Test Series A</b>	<b>Test Series B</b>	<b>Test Series C</b>	
<b>Elastic stiffness before slip (kN/mm)</b>	263.45	211.38	1-bolt joint: 2-bolt joint: 3-bolt joint: 4-bolt joint:	27.51 84.81 113.92 138.95
<b>Elastic stiffness during slip (kN/mm)</b>	20.99	-	1-bolt joint: 2-bolt joint: 3-bolt joint: 4-bolt joint:	- - - -
<b>Elastic stiffness during load transfer by splice angle only (kN/mm)</b>	43.65	-	1-bolt joint: 2-bolt joint: 3-bolt joint: 4-bolt joint:	- - - -
<b>Elastic stiffness during load transfer by direct contact of angles and by splice angle (kN/mm)</b>	86.55	-	1-bolt joint: 2-bolt joint: 3-bolt joint: 4-bolt joint:	- - - -
<b>Elastic Stiffness during load transfer by bolt bearing (kN/mm)</b>	-	58.31	1-bolt joint: 2-bolt joint: 3-bolt joint: 4-bolt joint:	23.75 53.81 56.19 77.81

- Not applicable

**Table 4.14 Load at commencement of slip as a ratio of load at other important loading stages of the loading process**

Description	Test Series A	Test Series B	Test Series C	
(Load at slip)/ (Load at end of slip)	Maximum Clearance: 0.37 Normal Clearance: 0.54	1.00	1-bolt joint: 2-bolt joint: 3-bolt joint: 4-bolt joint:	1.00 1.00 1.00 1.00 (1.00)
(Load at slip)/ (Load at end of load transfer through splice angle only)	0.20	-	1-bolt joint: 2-bolt joint: 3-bolt joint: 4-bolt joint:	- - - -
(Load at slip)/ (Load at onset of plasticity)	0.15	0.18	1-bolt joint: 2-bolt joint: 3-bolt joint: 4-bolt joint:	0.14 0.21 0.19 0.28 (0.21)
(Load at slip)/ (maximum load)	0.14	0.12	1-bolt joint: 2-bolt joint: 3-bolt joint: 4-bolt joint:	0.09 0.13 0.14 0.23 (0.15)

- Not applicable

( ) Mean value

**Table 4.15 Slip as a ratio of deformation at other important stages of the loading process**

Description	Test Series A		Test Series B		Test Series C			
	Maximum Clearance	Normal Clearance	Maximum Clearance	Normal Clearance		Maximum Clearance	Normal Clearance	
(Slip)/(Deformation under frictional load transfer)	12.03	6.31	8.18	2.00	1-bolt joint: 6.71 2-bolt joint: 9.79 3-bolt joint: 7.88 4-bolt joint: 6.26	(7.66)	2.88 4.29 2.19 2.41	(2.84)
(Slip)/(Deformation during load transfer by splice angle only)	1.18	0.62	-	-	1-bolt joint: - 2-bolt joint: - 3-bolt joint: - 4-bolt joint: -	-	-	-
(Slip)/(Deformation during load transfer by direct contact of angles and the splice angle)	4.36	2.29	-	-	1-bolt joint: - 2-bolt joint: - 3-bolt joint: - 4-bolt joint: -	-	-	-
(Slip)/(Deformation during load transfer by bolt bearing)	-	-	0.43	0.11	1-bolt joint: 0.83 2-bolt joint: 1.36 3-bolt joint: 0.85 4-bolt joint: 1.15	(1.05)	0.36 0.60 0.24 0.44	(0.41)
(Slip)/(Deformation between onset of plasticity and maximum load)	9.69	5.08	0.23	0.06	1-bolt joint: 0.38 2-bolt joint: 0.92 3-bolt joint: 0.94 4-bolt joint: 1.84	(1.02)	0.16 0.40 0.26 0.71	(0.38)
(Slip)/(Deformation reaches at onset of plasticity)	0.46	0.31	0.29	0.09	1-bolt joint: 0.43 2-bolt joint: 0.54 3-bolt joint: 0.44 4-bolt joint: 0.49	(0.48)	0.24 0.34 0.18 0.27	(0.26)
(Slip)/(Deformation reaches at maximum load)	0.44	0.29	0.13	0.03	1-bolt joint: 0.20 2-bolt joint: 0.34 3-bolt joint: 0.30 4-bolt joint: 0.39	(0.31)	0.10 0.19 0.11 0.20	(0.15)

- Not applicable

( ) Mean value

**Table 4.16 Maximum load as a ratio of member load bearing capacity as well as bolt load bearing capacity**

Description	Test Series A	Test Series B	Test Series C	
<b>(Maximum load)/(Net yield load of angle)</b>	1.22	1.72	1-bolt joint: 2-bolt joint: 3-bolt joint: 4-bolt joint:	0.60 0.54 0.63 0.60
<b>(Maximum load)/(Net ultimate load of angle)</b>	0.84	1.18	1-bolt joint: 2-bolt joint: 3-bolt joint: 4-bolt joint:	0.41 0.37 0.43 0.41
<b>(Maximum load)/(Ultimate shear load of bolts)</b>	1.03	0.71	1-bolt joint: 2-bolt joint: 3-bolt joint: 4-bolt joint:	1.49 1.09 0.94 0.72

**Table 4.17  $A_{ne}/A_g$  and  $A_s/A_{ne}$  ratios of Test Series A, B, and C**

Description	Test Series A	Test Series B	Test Series C	
$A_{ne}/A_g$	0.76	0.76	1-bolt joint: 2-bolt joint: 3-bolt joint: 4-bolt joint:	0.41 0.66 0.75 0.79
$A_s/A_{ne}$	1.12	2.33	1-bolt joint: 2-bolt joint: 3-bolt joint: 4-bolt joint:	0.38 0.47 0.63 0.87
Maximum load (kN)	299.68	205.08	1-bolt joint: 2-bolt joint: 3-bolt joint: 4-bolt joint:	107.78 157.71 204.40 207.55
Average shear stress in a bolt at failure (MPa)	378.52	259.04	1-bolt joint: 2-bolt joint: 3-bolt joint: 4-bolt joint:	544.49 398.42 344.21 262.10

$A_{ne}$  = Net effective cross sectional area of the smallest angle

$A_g$  = Gross cross sectional area of the smallest angle

$A_s$  = Shear area of bolts

**Table 4.18 Results of direct tension tests on bolts**

Bolt type	Specimen Number	Maximum Bolt Elongation in inches	Maximum Strain in mm/mm	Tensile Strength		Failure Mode
				in kips	in Mpa**	
B33.4 Grade 5	1	0.143	0.082	30.13	890.16	Thread Failure
	2	0.131	0.075	26.46	785.13	Thread Failure
	3	0.145	0.089	30.20	896.10	Thread Failure
	4	0.159	0.098	33.10	982.15	Thread Failure
	5	0.162	0.103	31.37	945.79	Thread Failure
	<b>Mean</b>	0.148	0.089	30.25	899.87	
	<b>C.O.V.* (%)</b>	8.55	12.77	8.06	8.27	
A325 Galvanized	1	0.211	0.141	31.63	949.00	Tensile Failure
	2	0.227	0.144	30.99	925.75	Tensile Failure
	3	0.219	0.152	31.77	954.57	Tensile Failure
	<b>Mean</b>	0.219	0.146	31.46	943.11	
	<b>C.O.V.* (%)</b>	3.65	3.90	1.32	1.62	
A325-NG***	1	0.242	0.163	31.22	968.81	Tensile Failure

\* Coefficient of Variation = Standard Deviation/Mean Value x 100

\*\* Tensile Strength calculation based on stress area equal to  $0.7854 (D-0.9743/n)^2$   
Where D = nominal bolt diameter in inches, n = number of threads per inch.

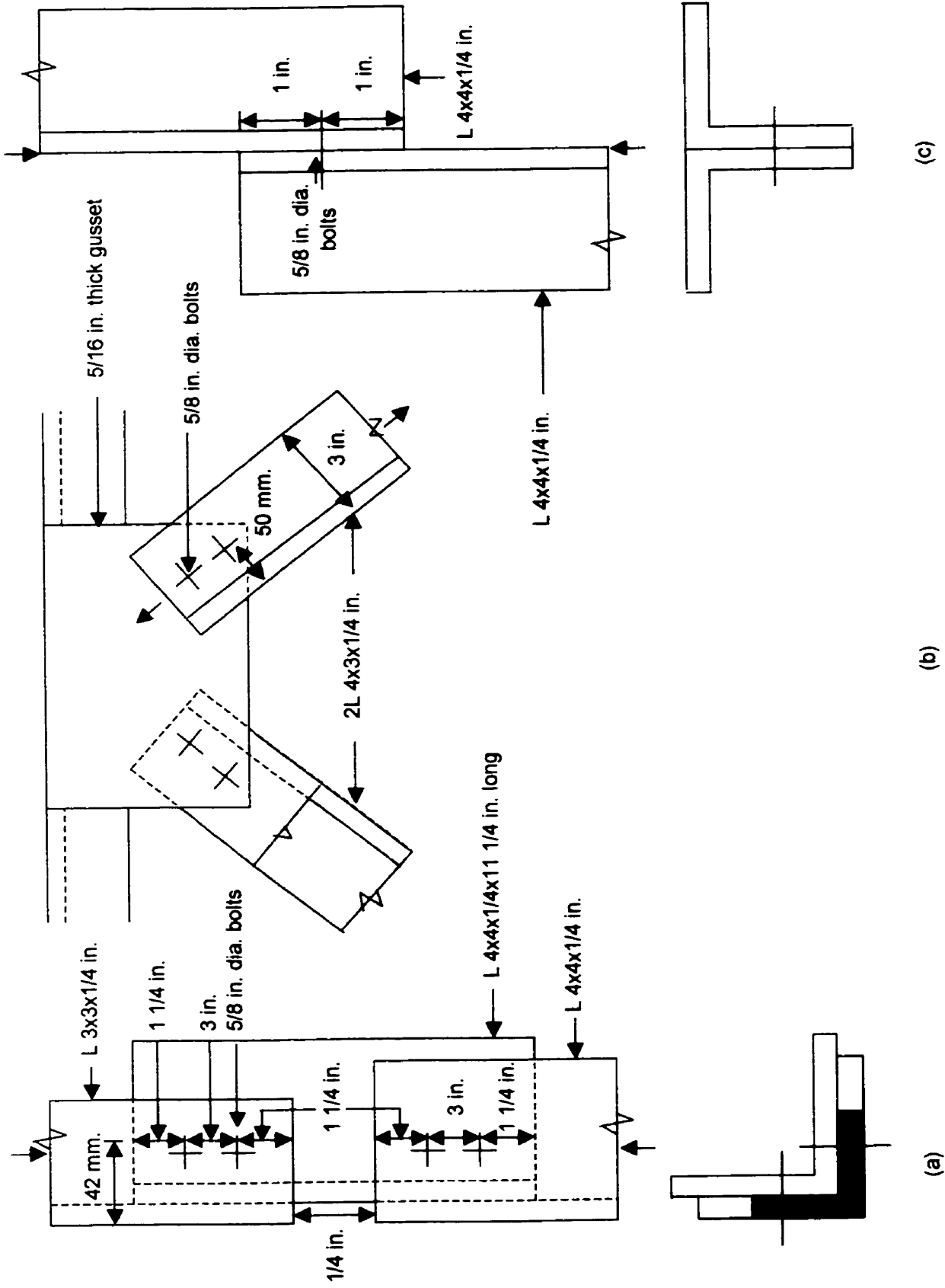
\*\*\* Non-galvanized A325 bolt

**Table 4.19 Results of tension tests on steel angle sections**

	<b>Specimen</b>	<b>Yield strength in MPa (1)</b>	<b>Tensile strength in MPa (2)</b>	<b>Modulus of elasticity in GPa</b>	<b>Percent of elongation</b>	<b>Percent of reduction in area</b>	<b>(2)/(1)</b>
L 3x3x1/4	A	325.63	496.68	206.18	33.77	57.23	1.53
	B	342.84	512.18	231.53	32.9	59.67	1.49
L 4x3x1/4	C (3"leg)	339.64	500.2	201.44	31.46	52.96	1.47
	D (4"leg)	341.08	493.95	235.74	31.56	55.29	1.45
L 4x4x1/4	E	370.4	517.48	219.36	32.68	56.25	1.40
	F	365.67	523.43	193.78	31.71	53.93	1.43
<b>Mean</b>		<b>347.54</b>	<b>507.32</b>	<b>214.67</b>	<b>32.35</b>	<b>55.89</b>	<b>1.46</b>
<b>C.O.V (%)</b>		<b>4.91</b>	<b>2.38</b>	<b>7.89</b>	<b>2.85</b>	<b>4.31</b>	<b>3.13</b>

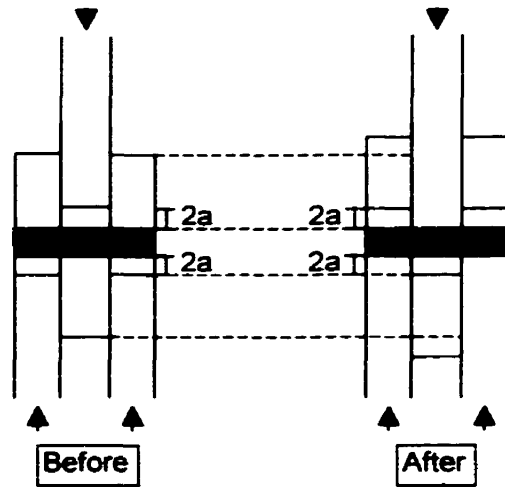
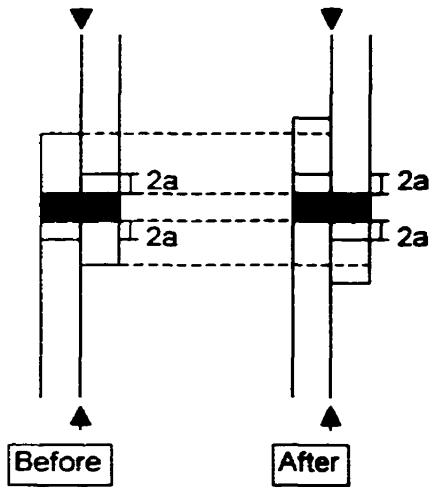


## **APPENDIX B - FIGURES**

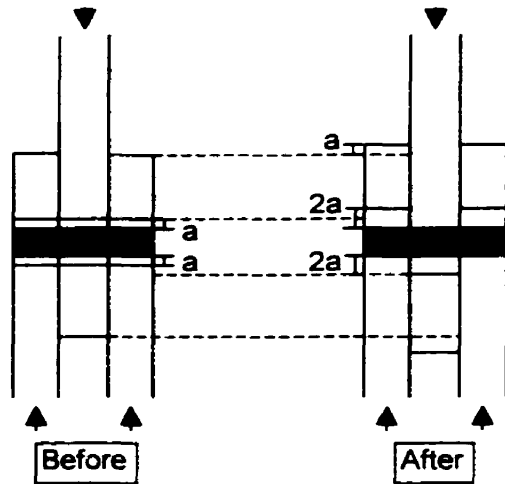
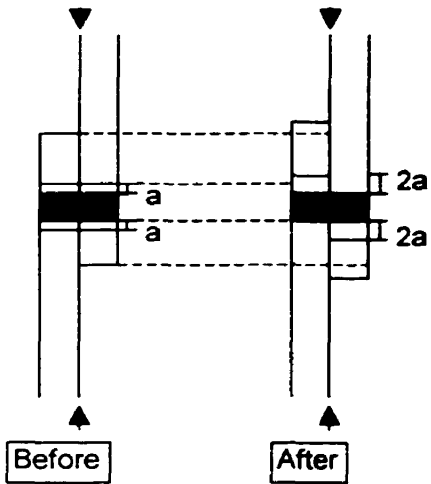


184 Note: Figures are not to scale.

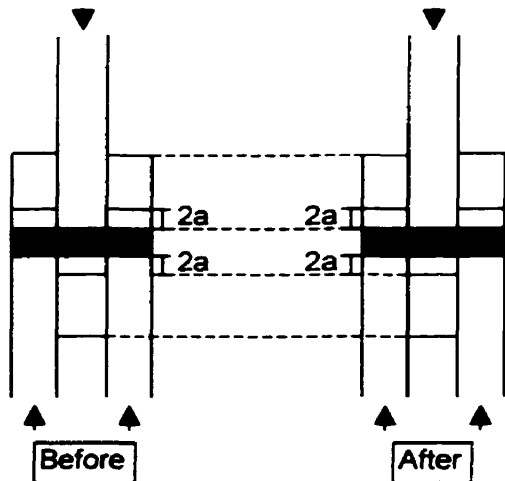
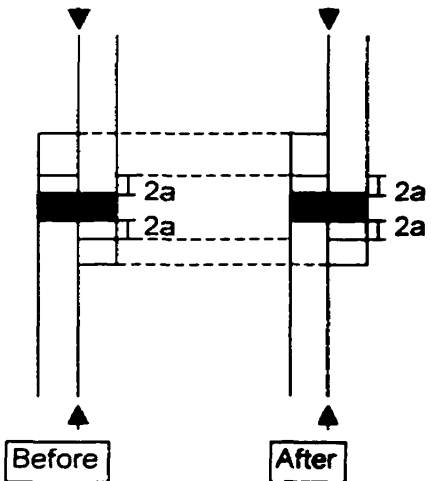
Figure 3.1 Joints of transmission line towers selected for study



(i) Maximum construction clearance



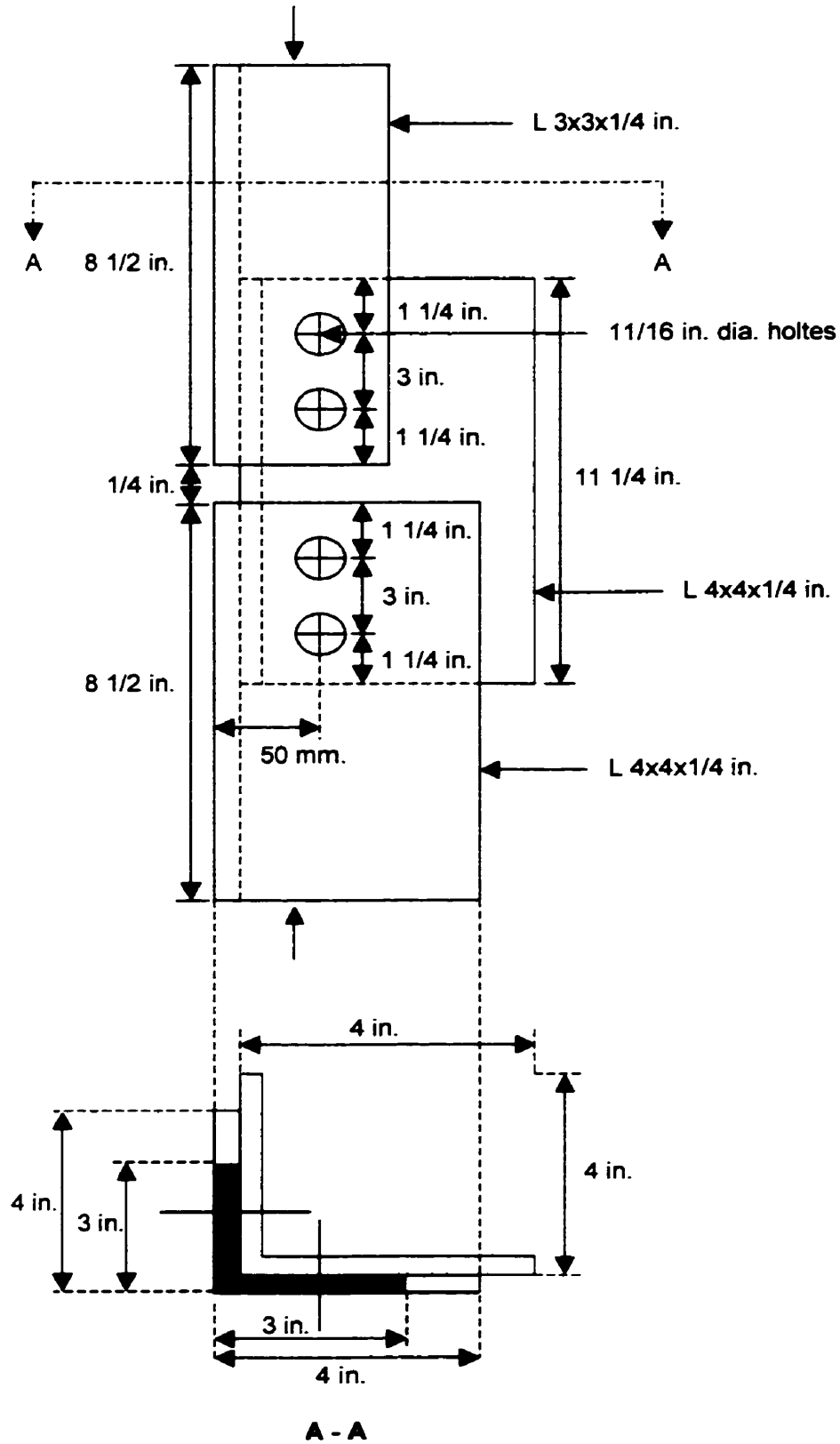
(ii) Normal construction clearance



(iii) Set in bearing

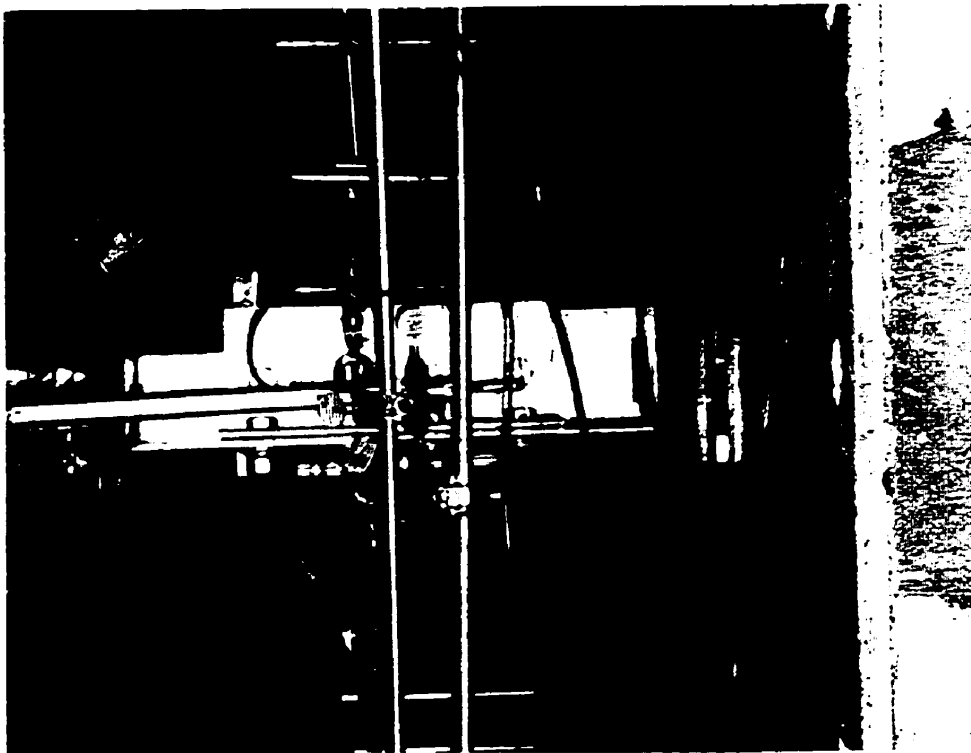
Note:  $a = 1/32$  in. (0.79 mm) and bolt diameter =  $5/8$  in. (15.88 mm)

**Figure 3.2 Different settings of construction clearance at assembly**

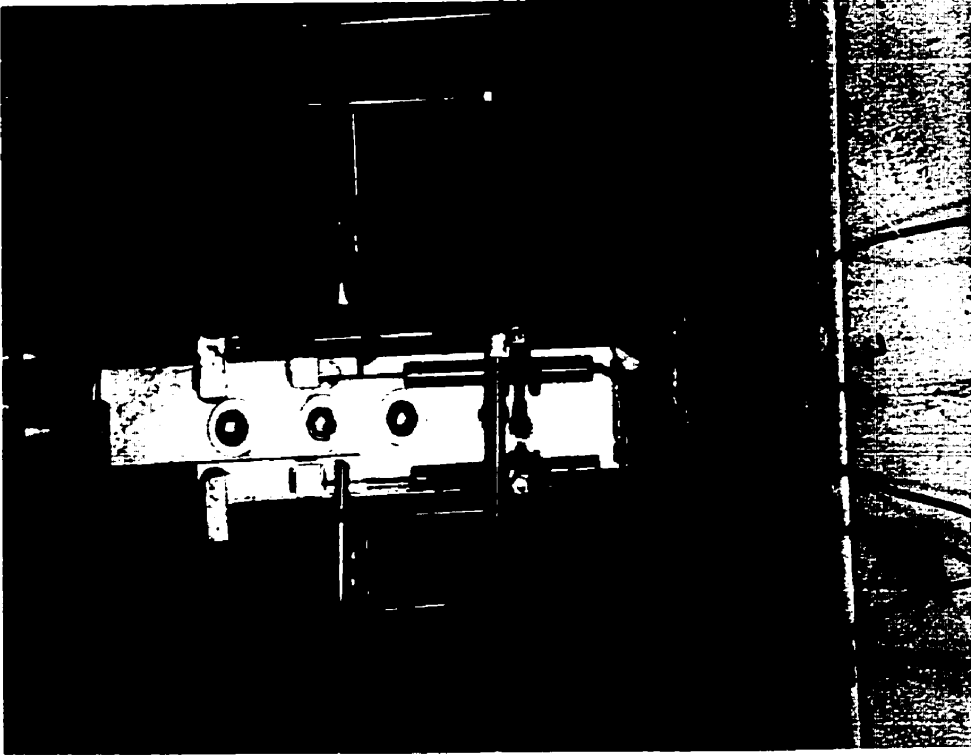


Note: Figures are not to scale

**Figure 3.3 Details of a test specimen of Test Series A**



(a) Front View



(b) Rear View

**Figure 3.4 Test Series A specimen in position for testing**

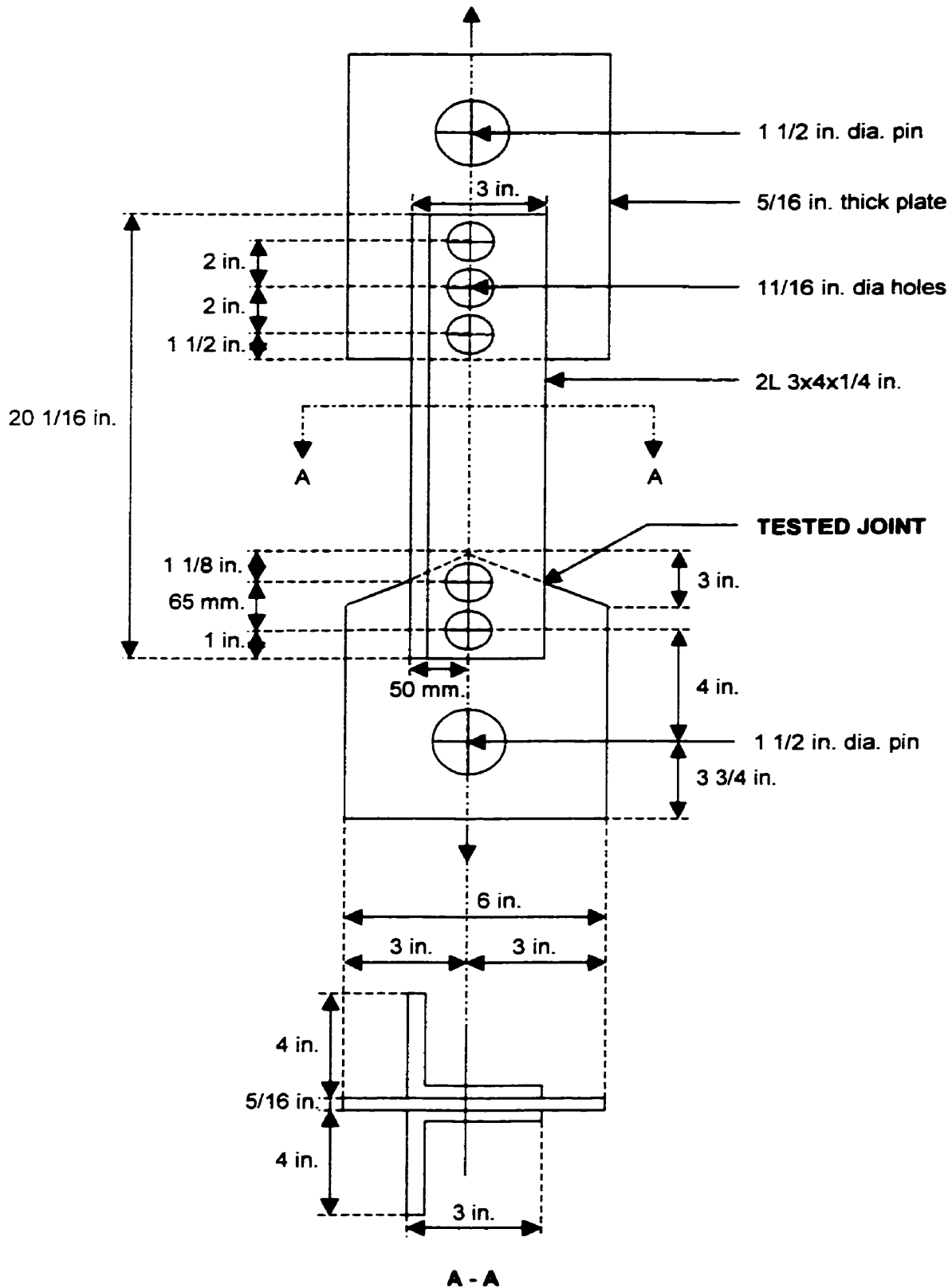


(a) MTS 445 Servo Hydraulic Testing Machine



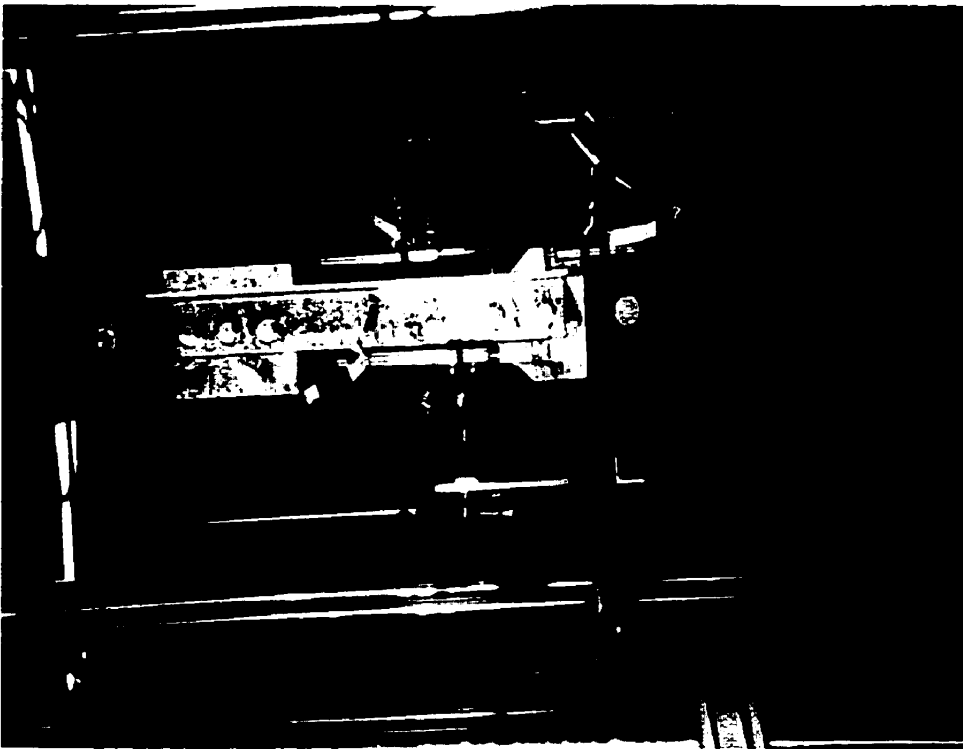
(b) National Instrument Data Acquisition

**Figure 3.5 MTS 445 Servo Hydraulic Testing Machine and National Instrument Data Acquisition**



Note: Figures are not to scale

Figure 3.6 Details of a specimen of Test Series B



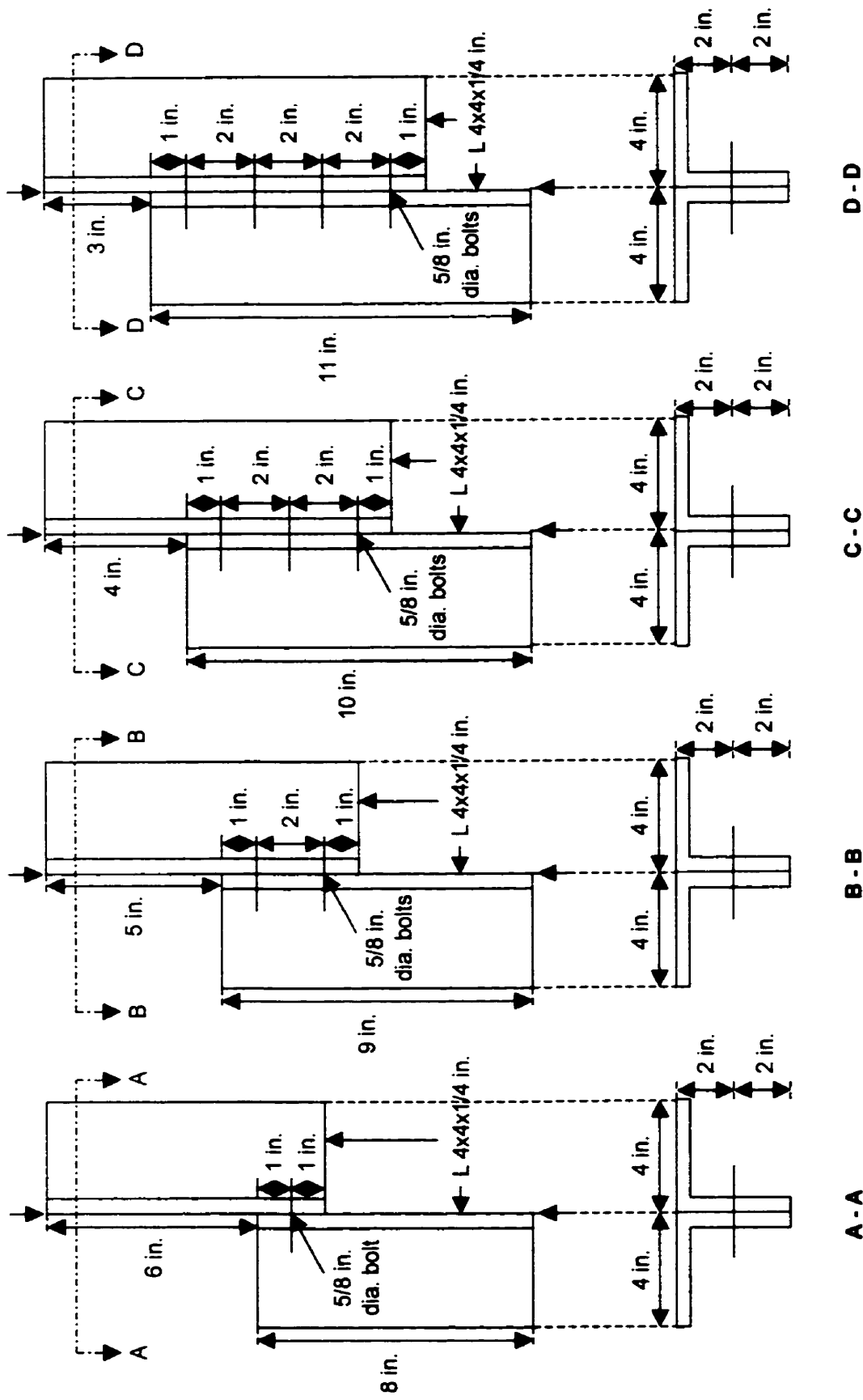
(a) Front View



(b) Side View

**Figure 3.7 Test Series B specimen in position for testing**





(a) Single bolted joint

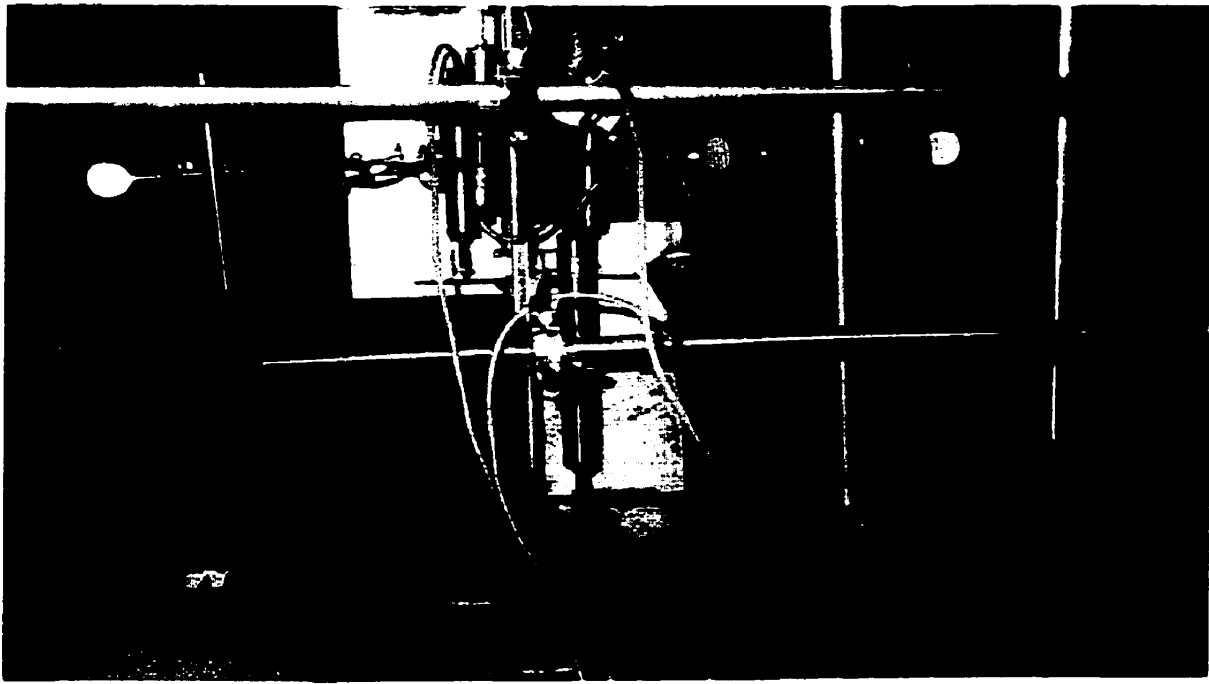
(b) 2-bolt joint

(c) 3-bolt joint

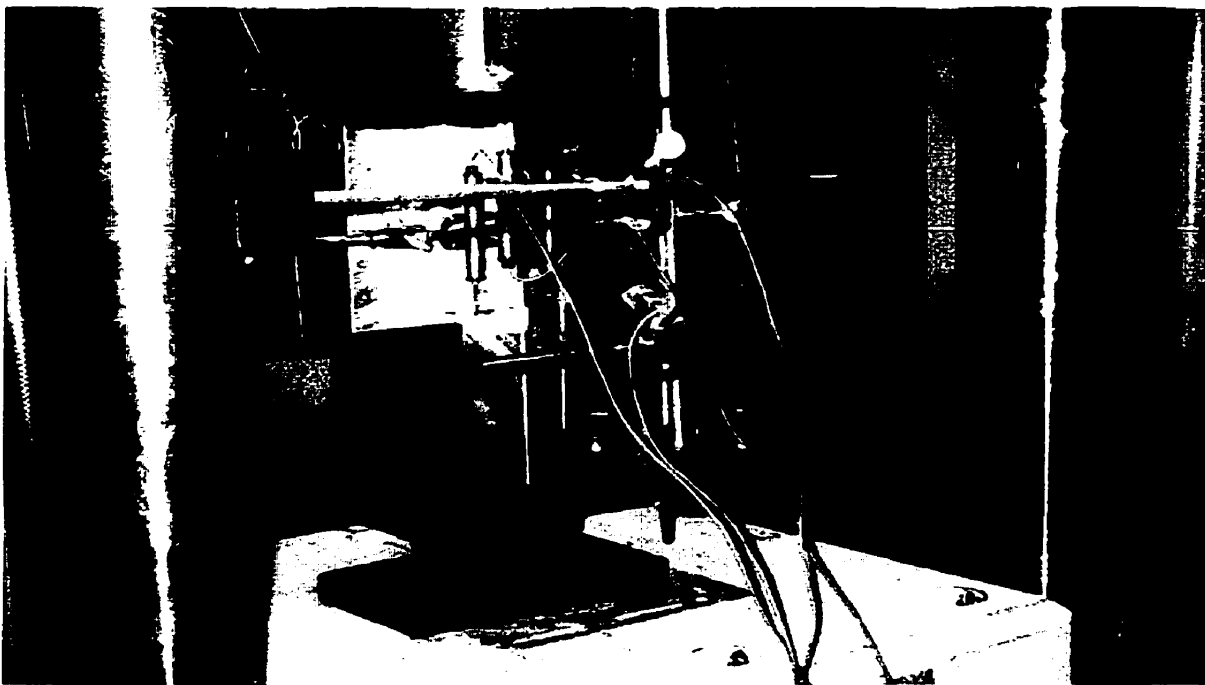
(d) 4-bolt joint

19 | Note: Figures are not to scale

Figure 3.8 Details of test specimens of Test Series C

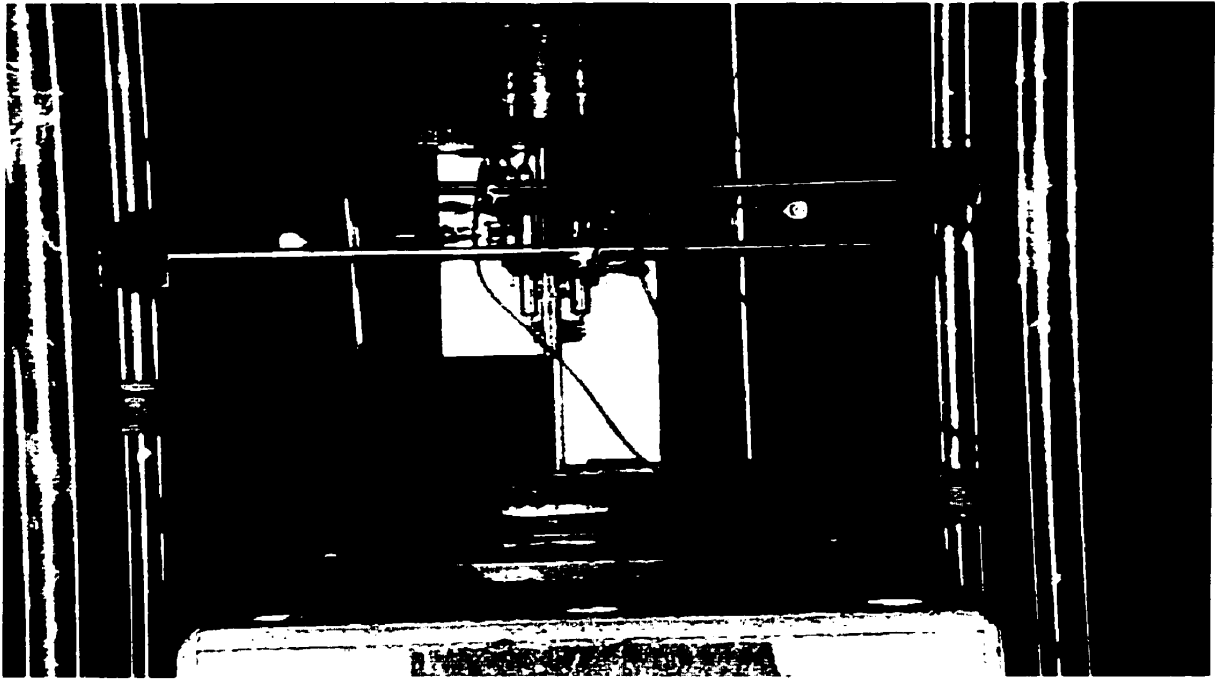


(a) Front View

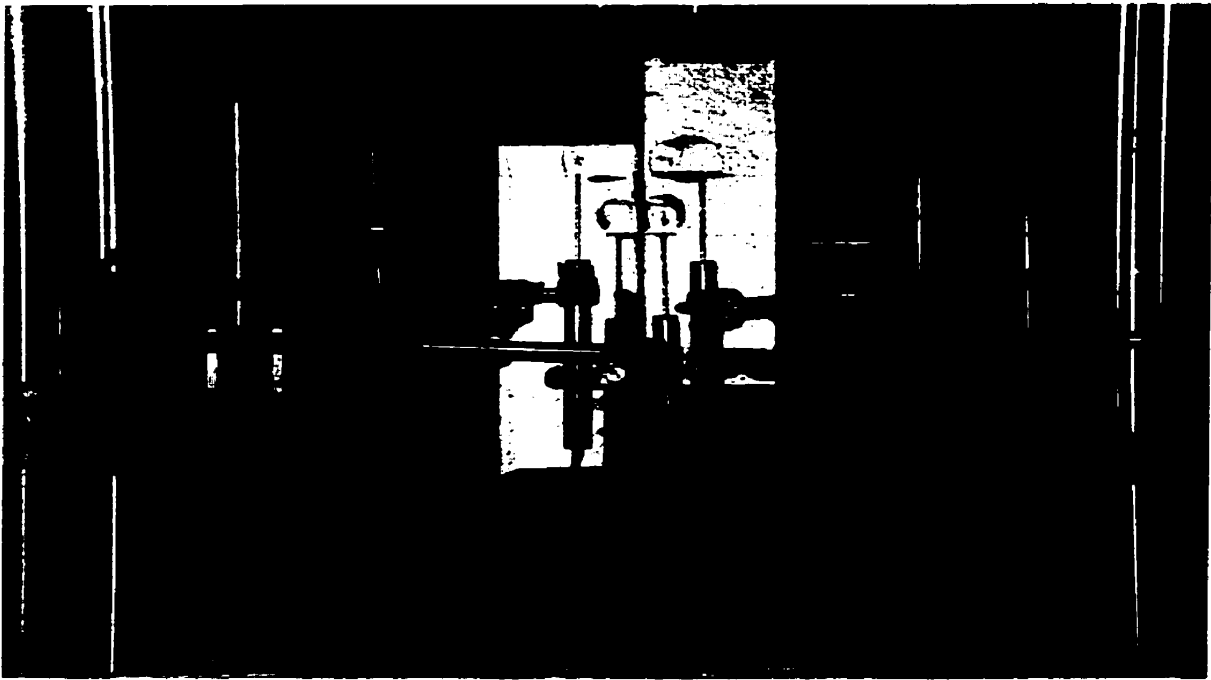


(b) Side View

**Figure 3.9 Single bolt specimen of Test Series C in position for testing**



(a) Front View

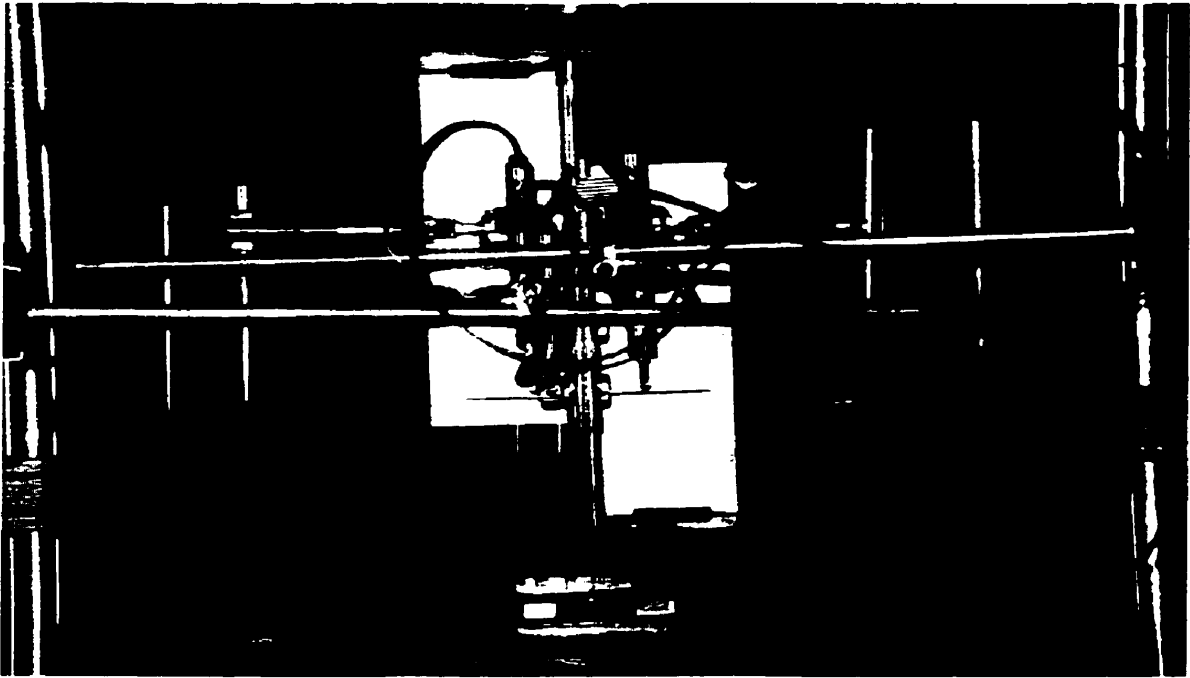


(b) Rear View

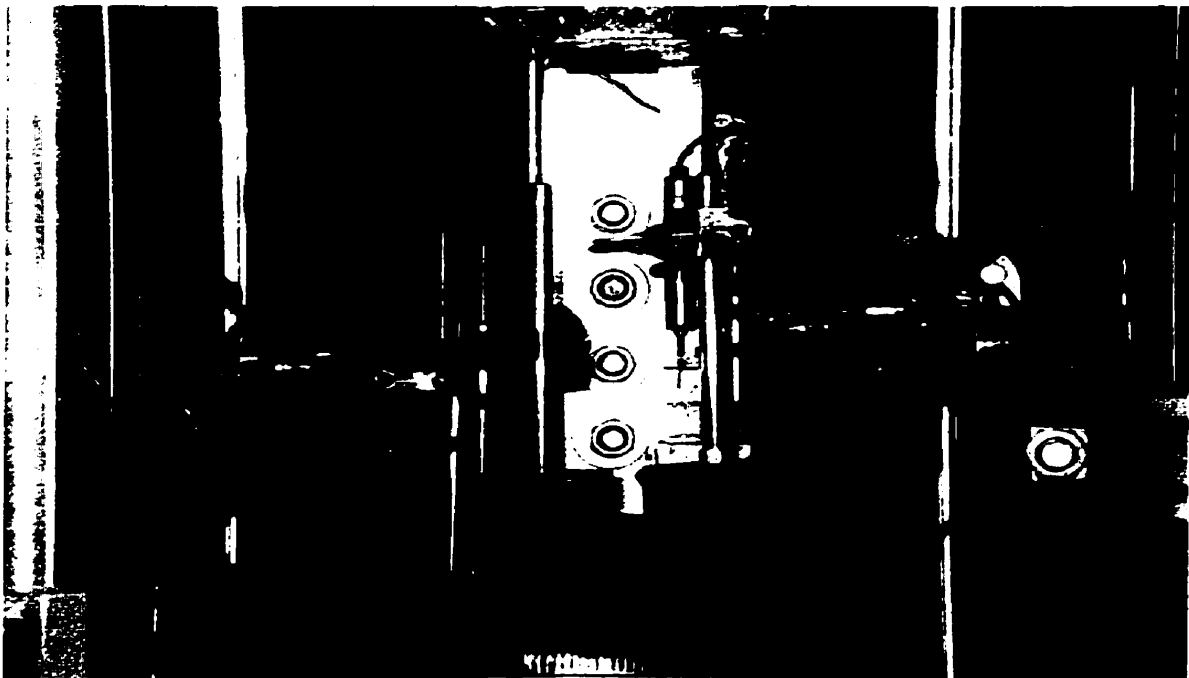
**Figure 3.10 Two-bolt specimen of Test Series C in position for testing**



**Figure 3.11 Three-bolt specimen of Test Series C in position for testing**

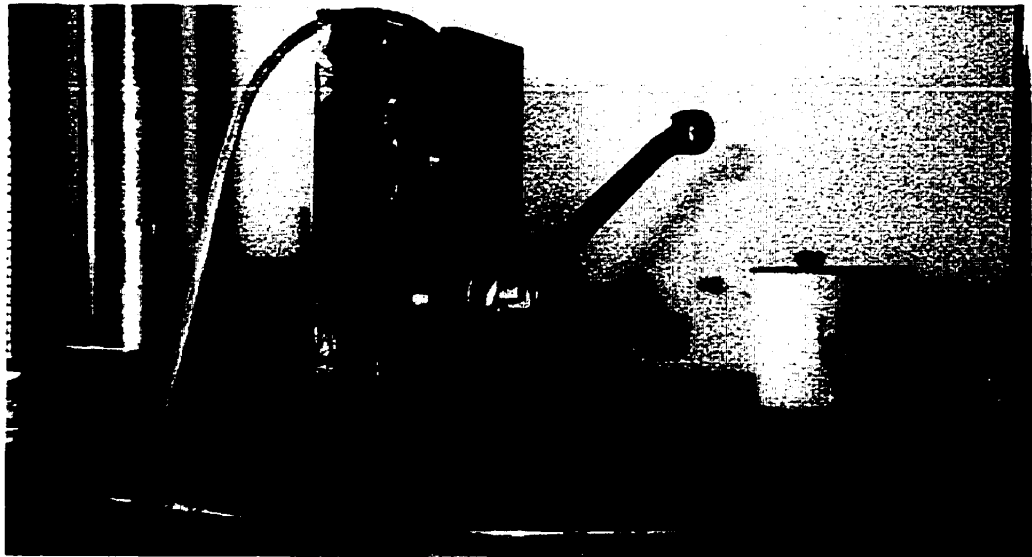


(a) Front View

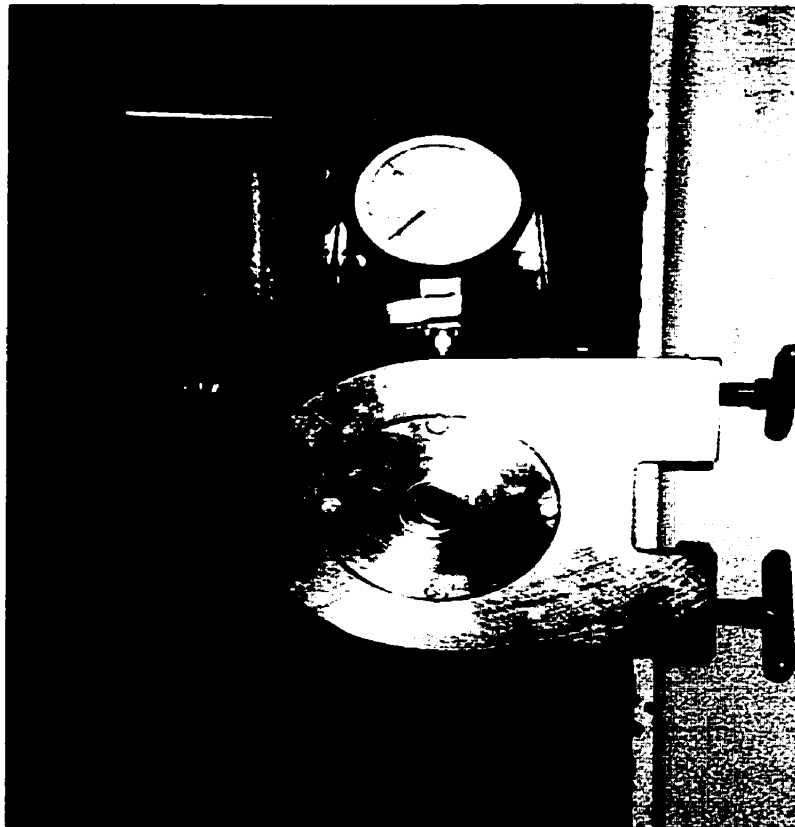


(b) Side View

**Figure 3.12 Four-bolt specimen of Test Series C in position for testing**



(a) Custom Designed Test Rig

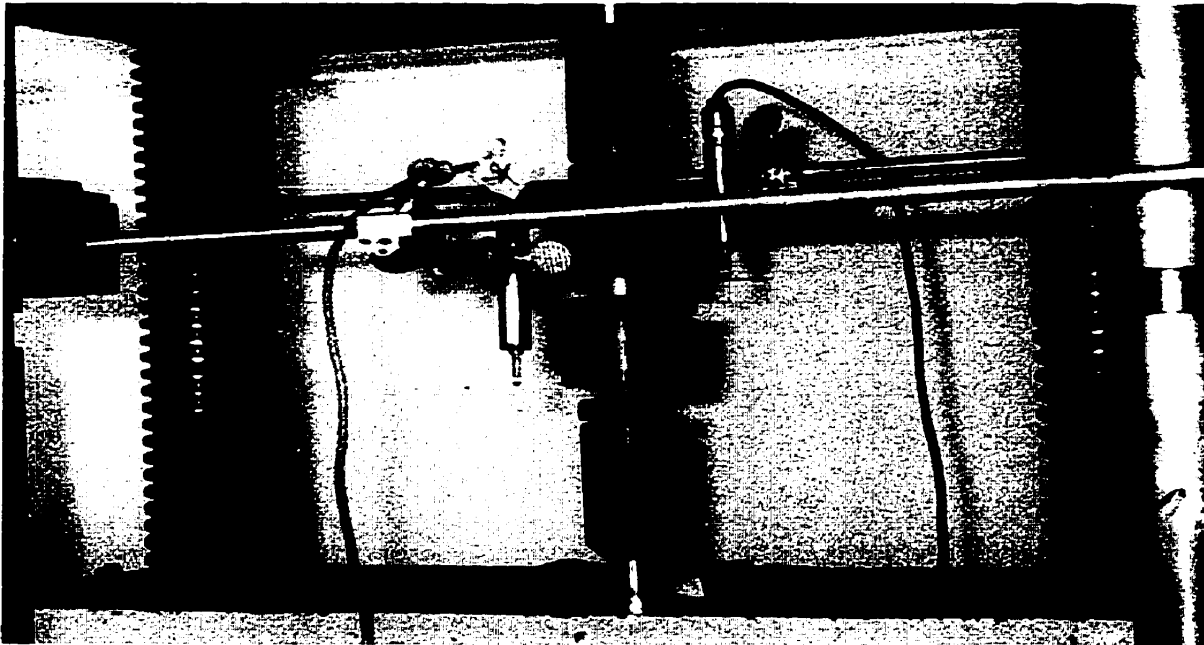


(b) Skidmore-Wilhelm Hydraulic Bolt Calibration

**Figure 3.13 Two methods used for bolt calibration by turn-of-nut**

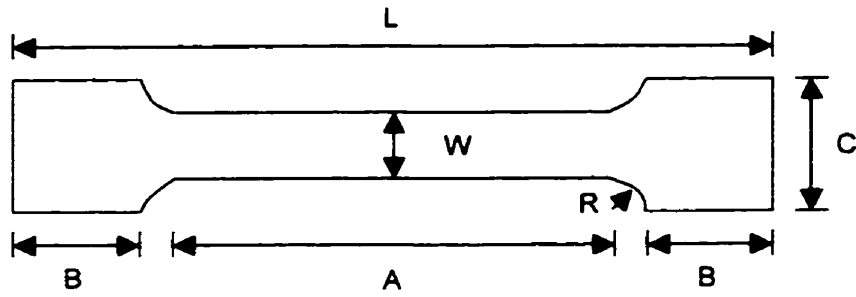


(a) Test Set up



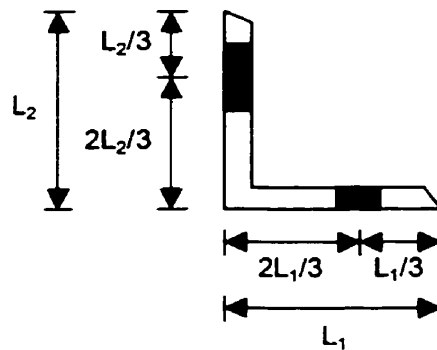
(b) Close up of test specimen

**Figure 3.14 A bolt specimen of Test Series E in position for the direct tension test**



	Dimensions (inches)
A - Length of reduced section	3
B - Length of grip section	2
C - Width of grip section	1
W - Width	0.500 $\pm$ 0.010
R - Radius of fillet	1/2
L - Over-all length	8

(a) Dimensional details of a test coupon



(b) Location of test coupons from a steel angle section

Note: Figures are not to scale

**Figure 3.15 Details and location of test coupons from a steel angle section**<sub>198</sub>



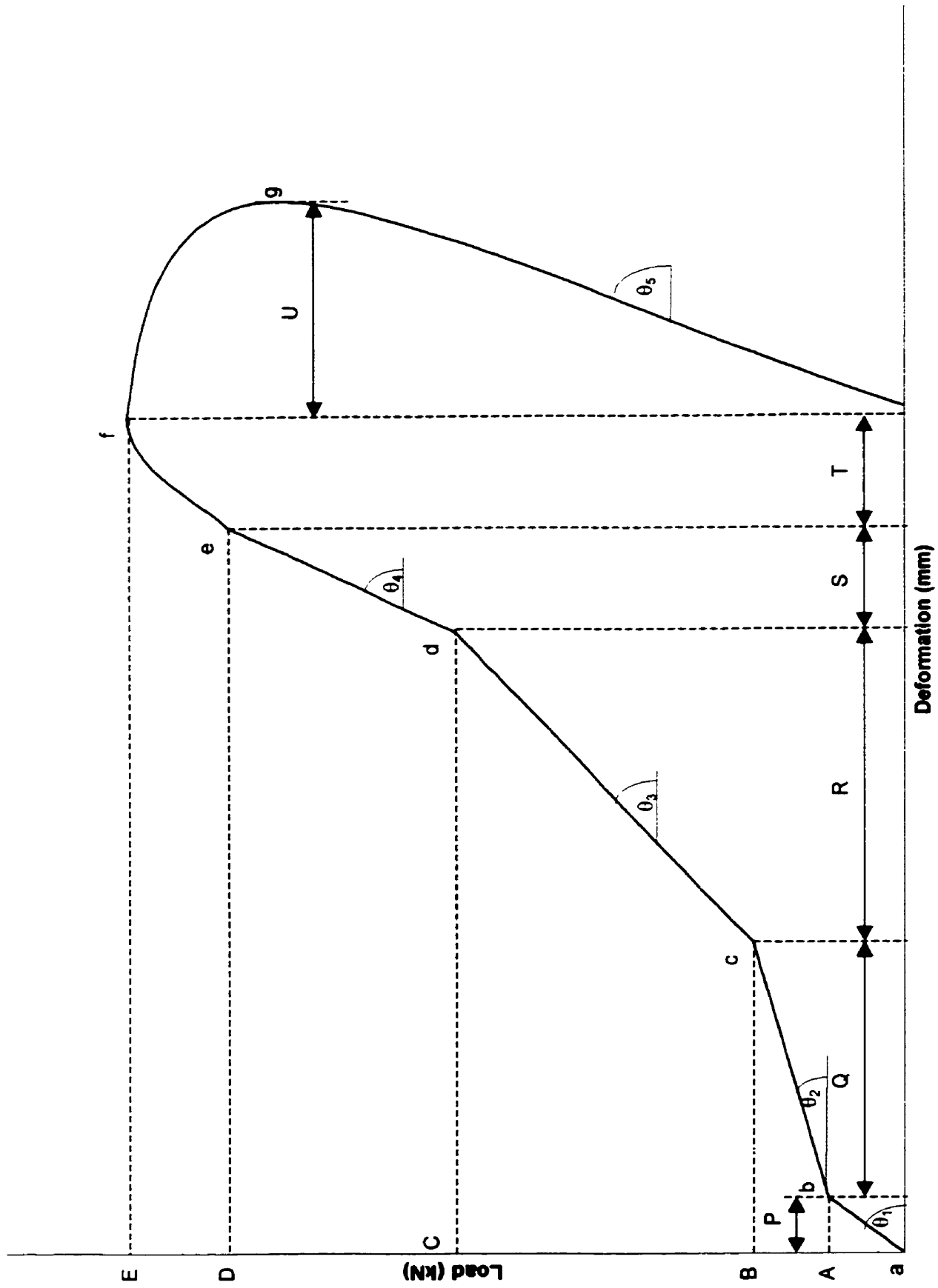
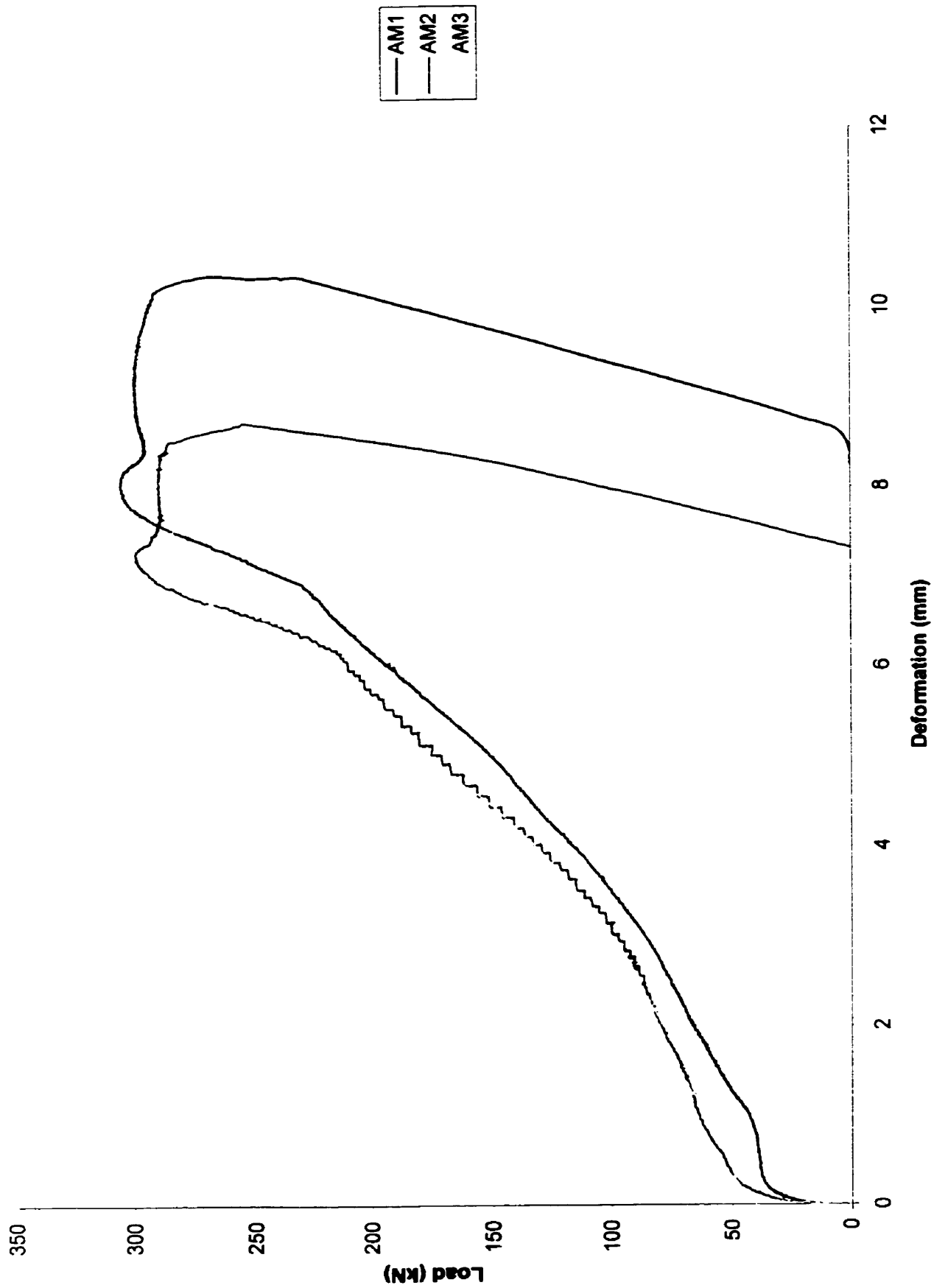
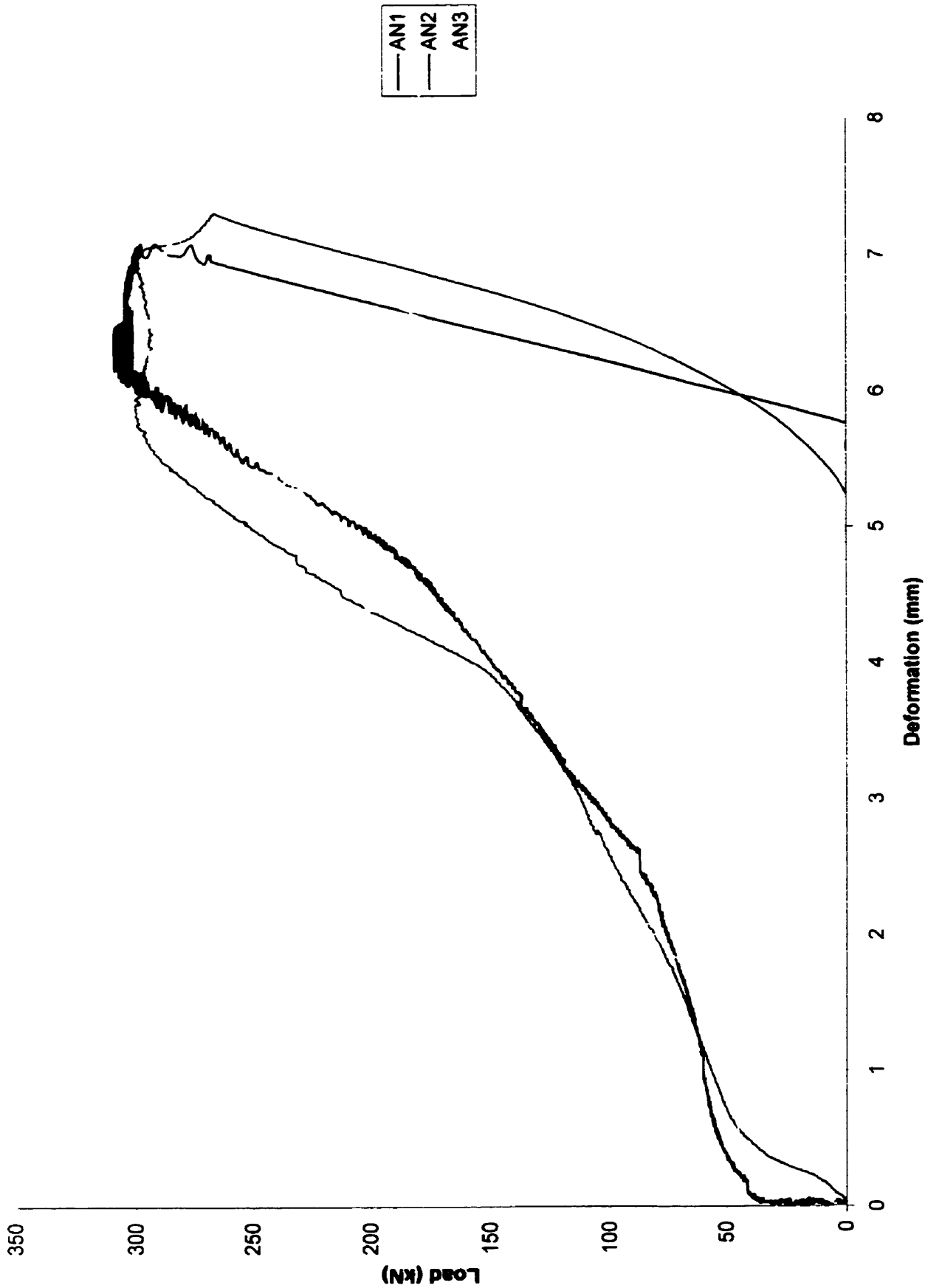


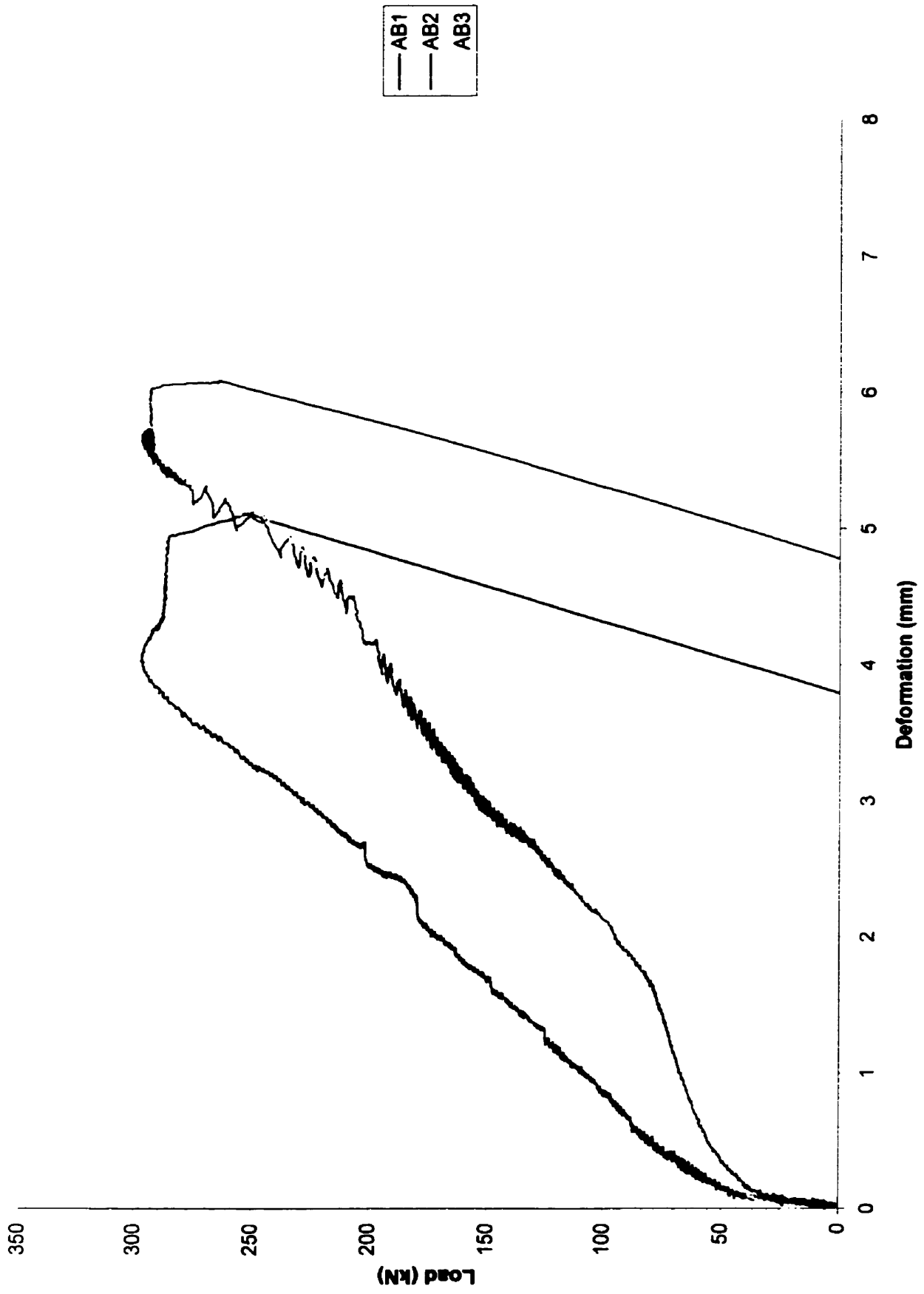
Figure 4.1 A typical load versus total joint deformation diagram for Test Series A



**Figure 4.2 Load versus total joint deformation diagrams for joints with maximum construction clearance (3.18 mm) at assembly of Test Series A**



**Figure 4.3 Load versus total joint deformation diagrams for joints with normal construction clearance (1.59 mm) at assembly of Test Series A**



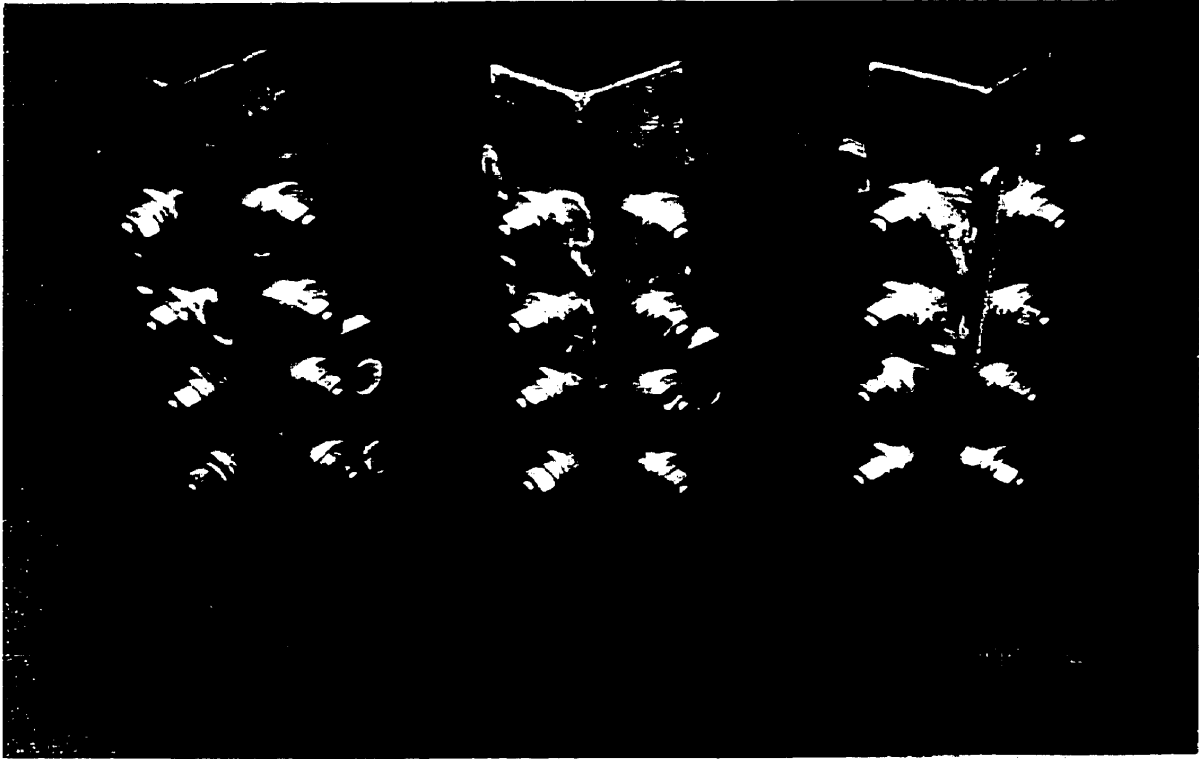
**Figure 4.4 Load versus total joint deformation diagrams for joints set in bearing at assembly of Test Series A**



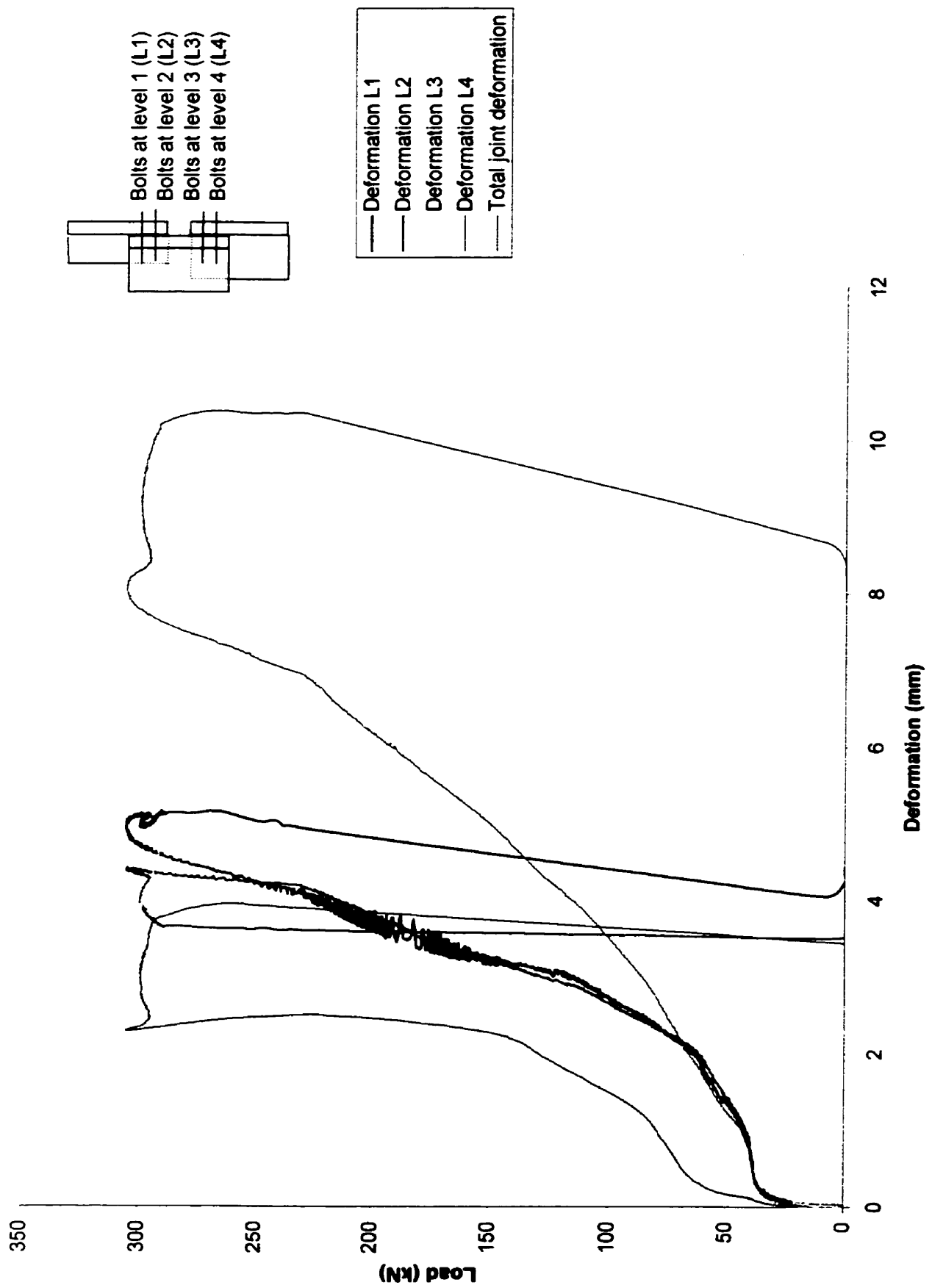
**Figure 4.5 Deformation on one leg of the top angle at failure**



**Figure 4.6 Deformation on the other leg of the top angle at failure**

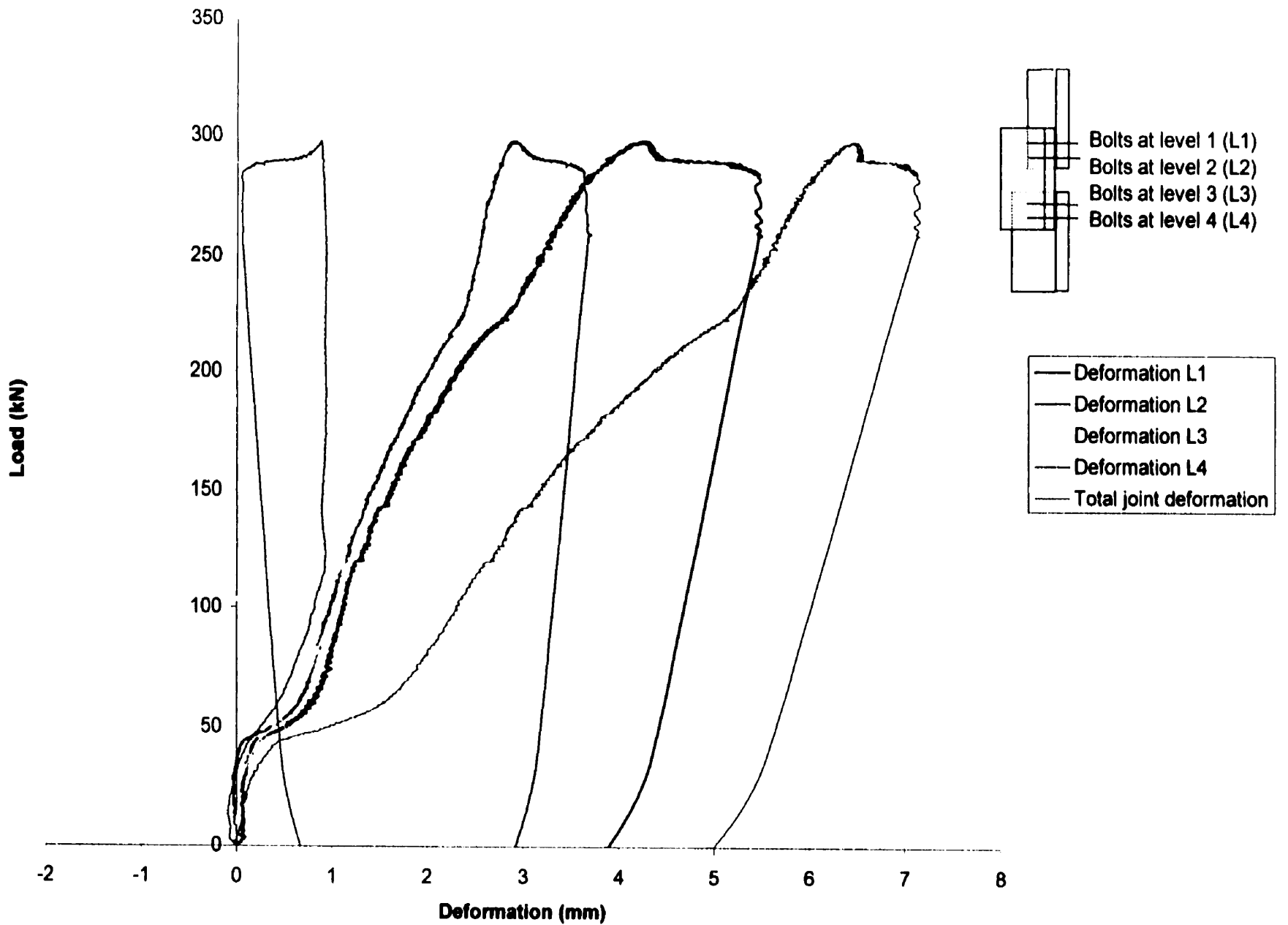


**Figure 4.7 Movement of top and bottom angle to make direct contact with each other at failure and prior to failure**

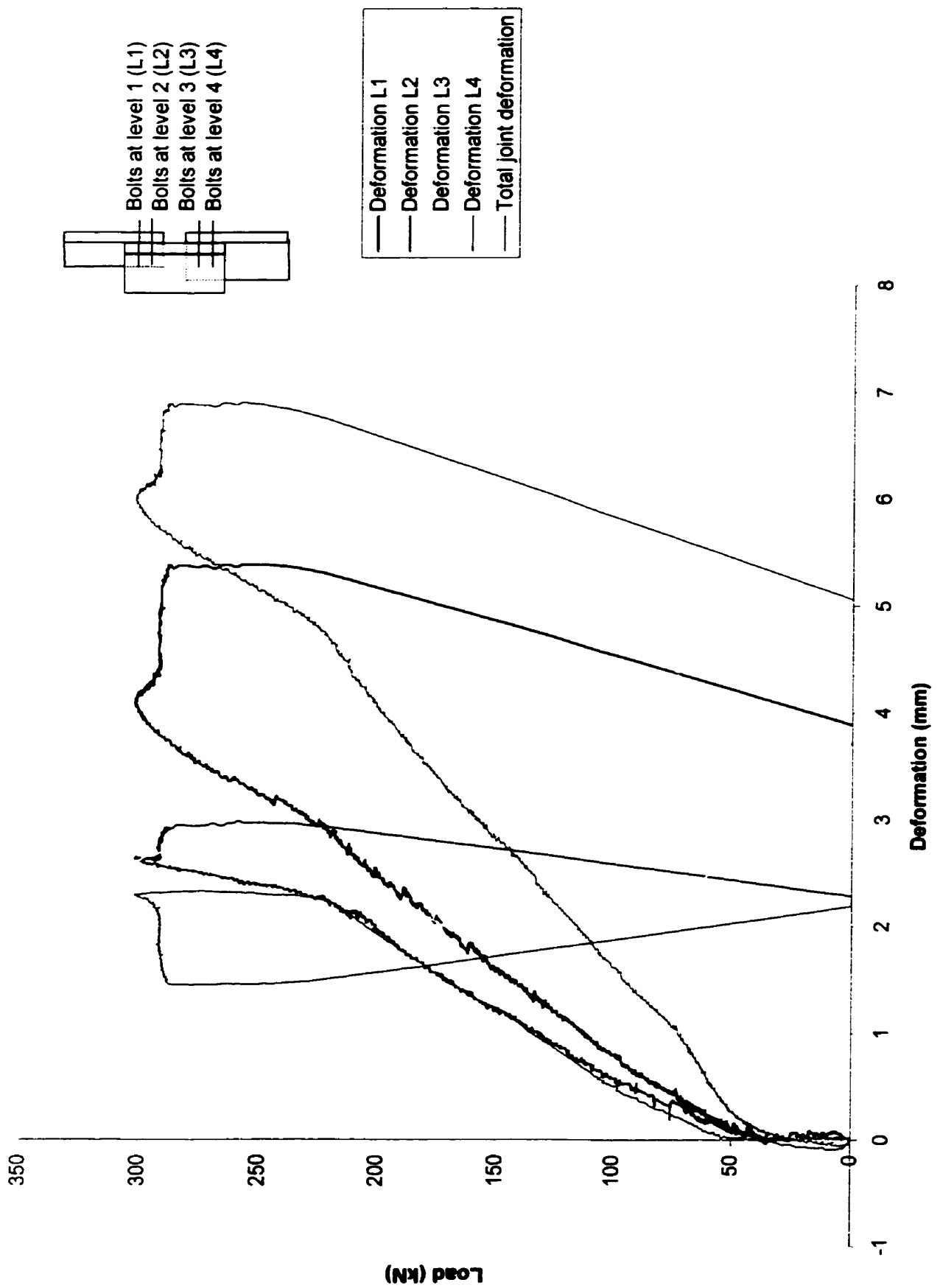


**Figure 4.8 Typical variations of load versus individual bolt row deformation and total joint deformation of specimens with maximum construction clearance (3.18 mm) at assembly of Test Series A (Specimen AM1)**

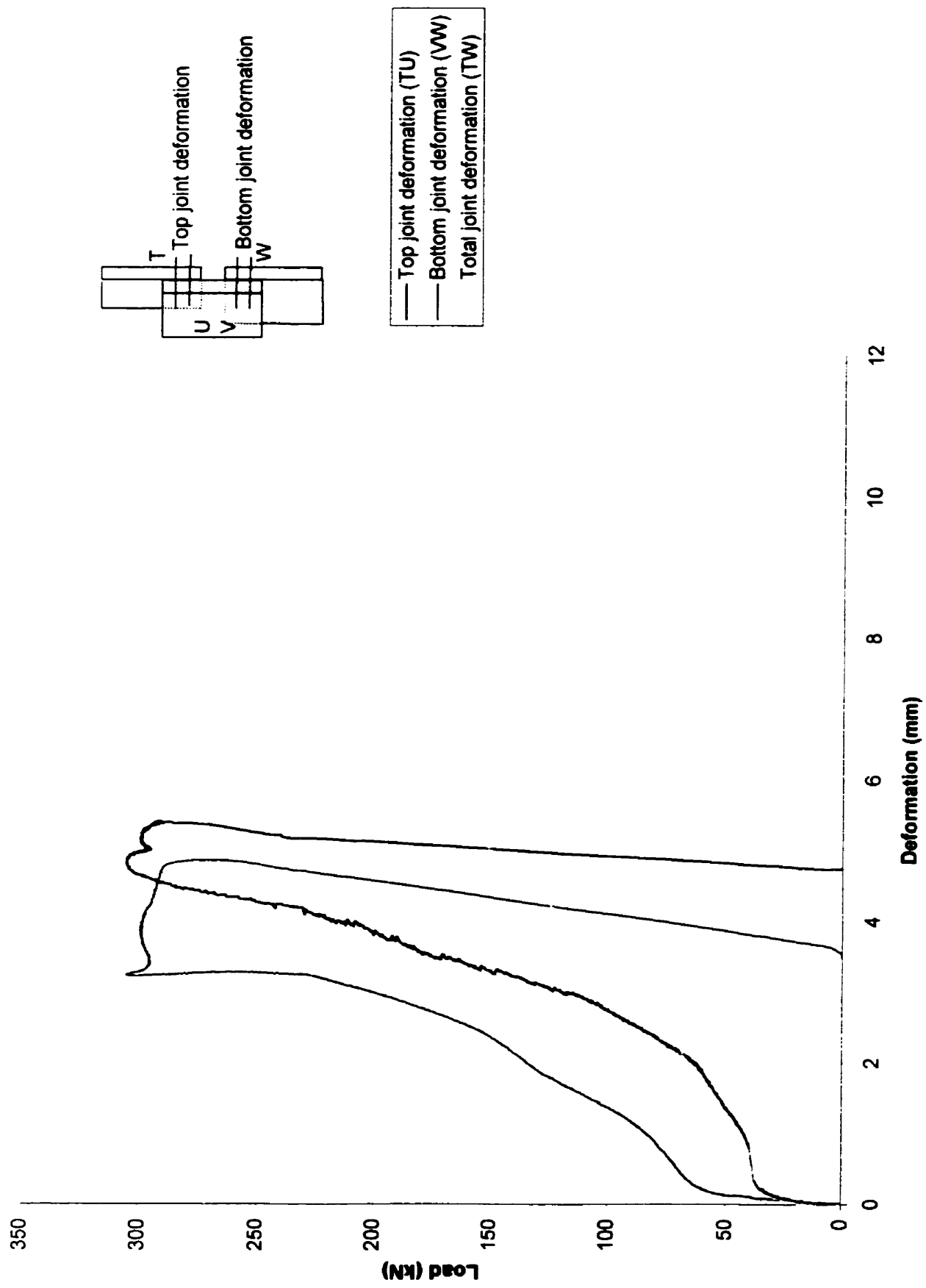




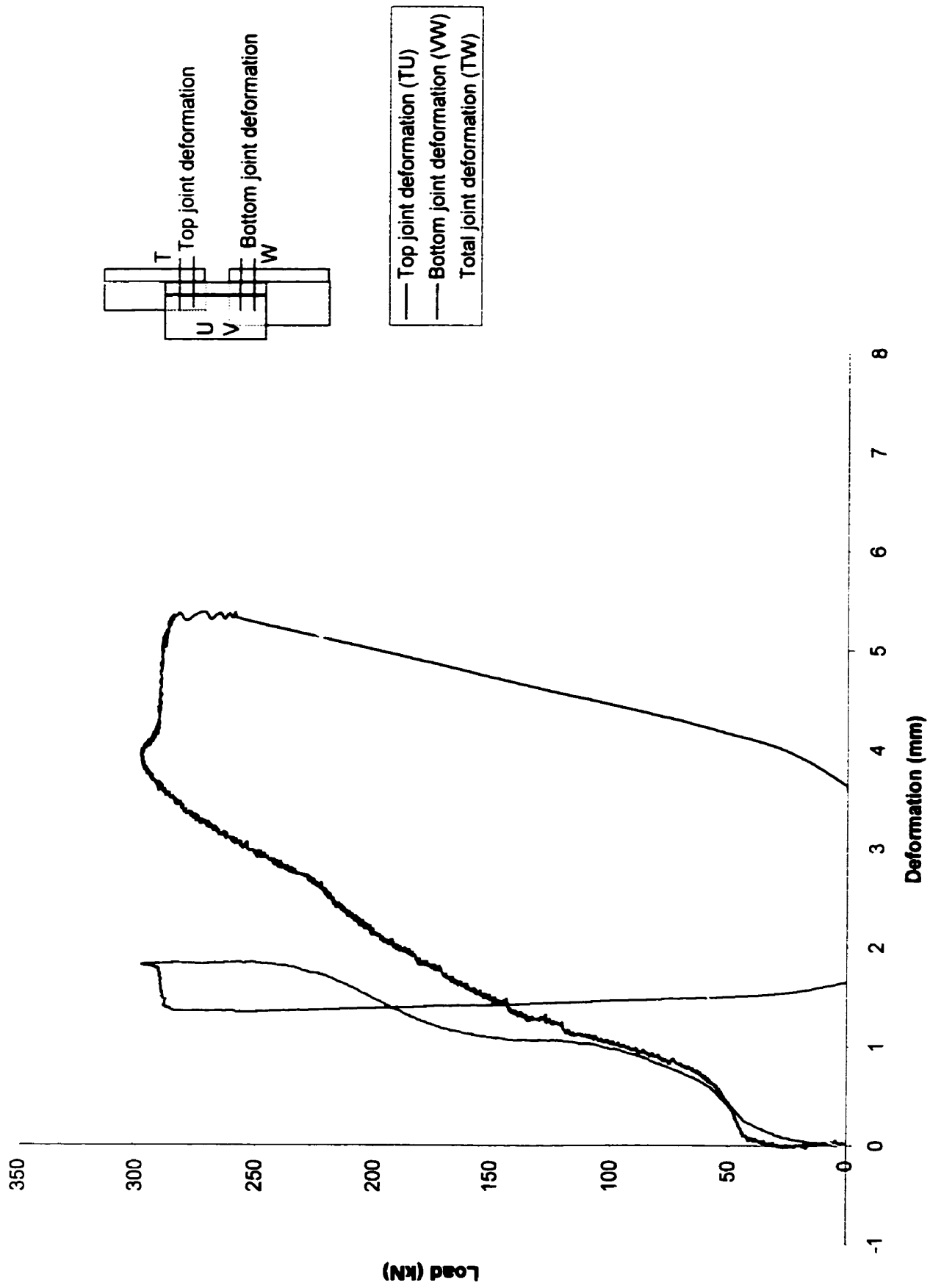
**Figure 4.9 Typical variations of load versus individual bolt row deformation and total joint deformation of specimens with normal construction clearance (1.59 mm) at assembly of Test Series A (Specimen AN3)**



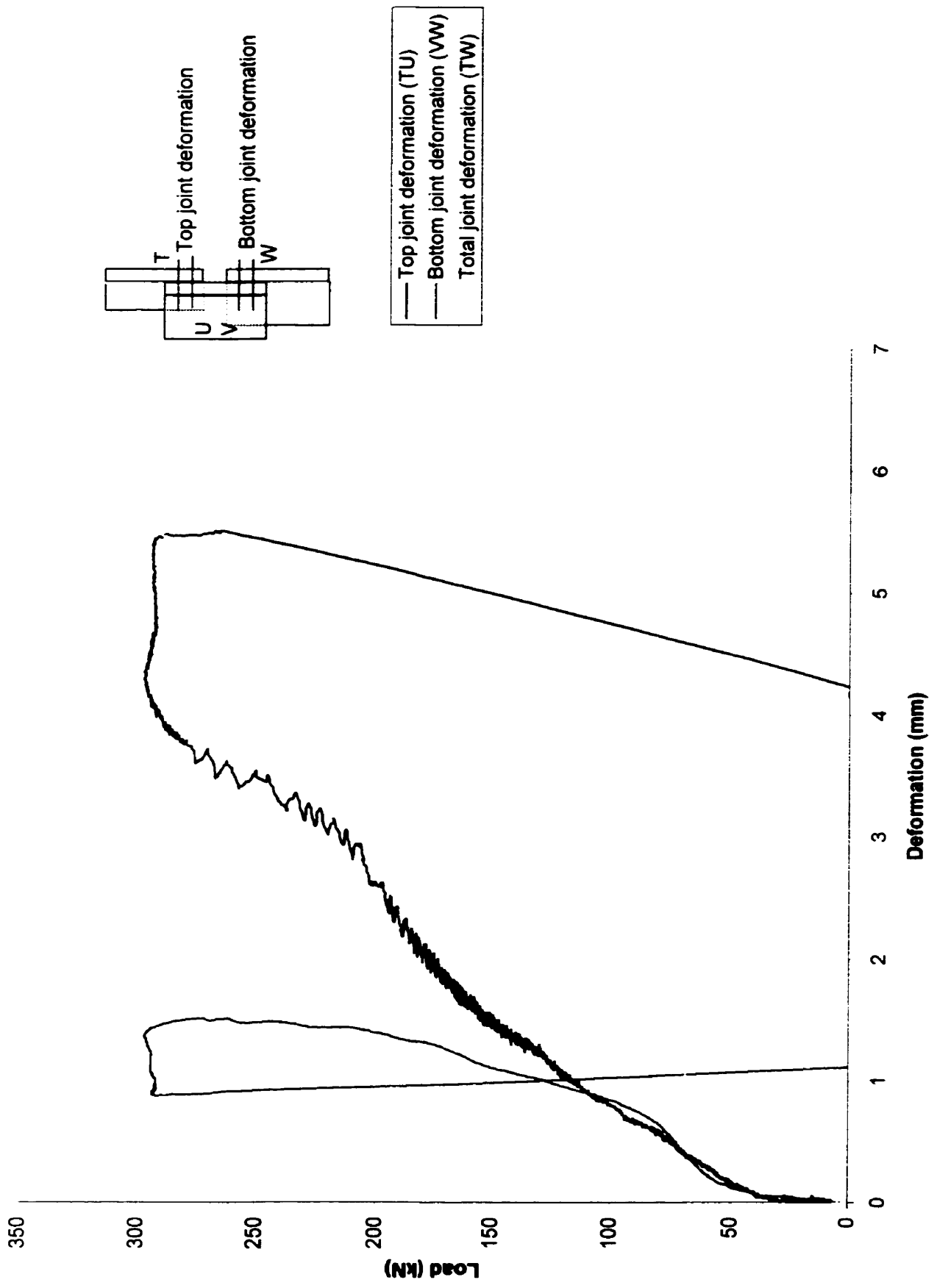
**Figure 4.10 Typical variations of load versus individual bolt row deformation and total joint deformation of specimens set in bearing at assembly of Test Series A (Specimen AB3)**



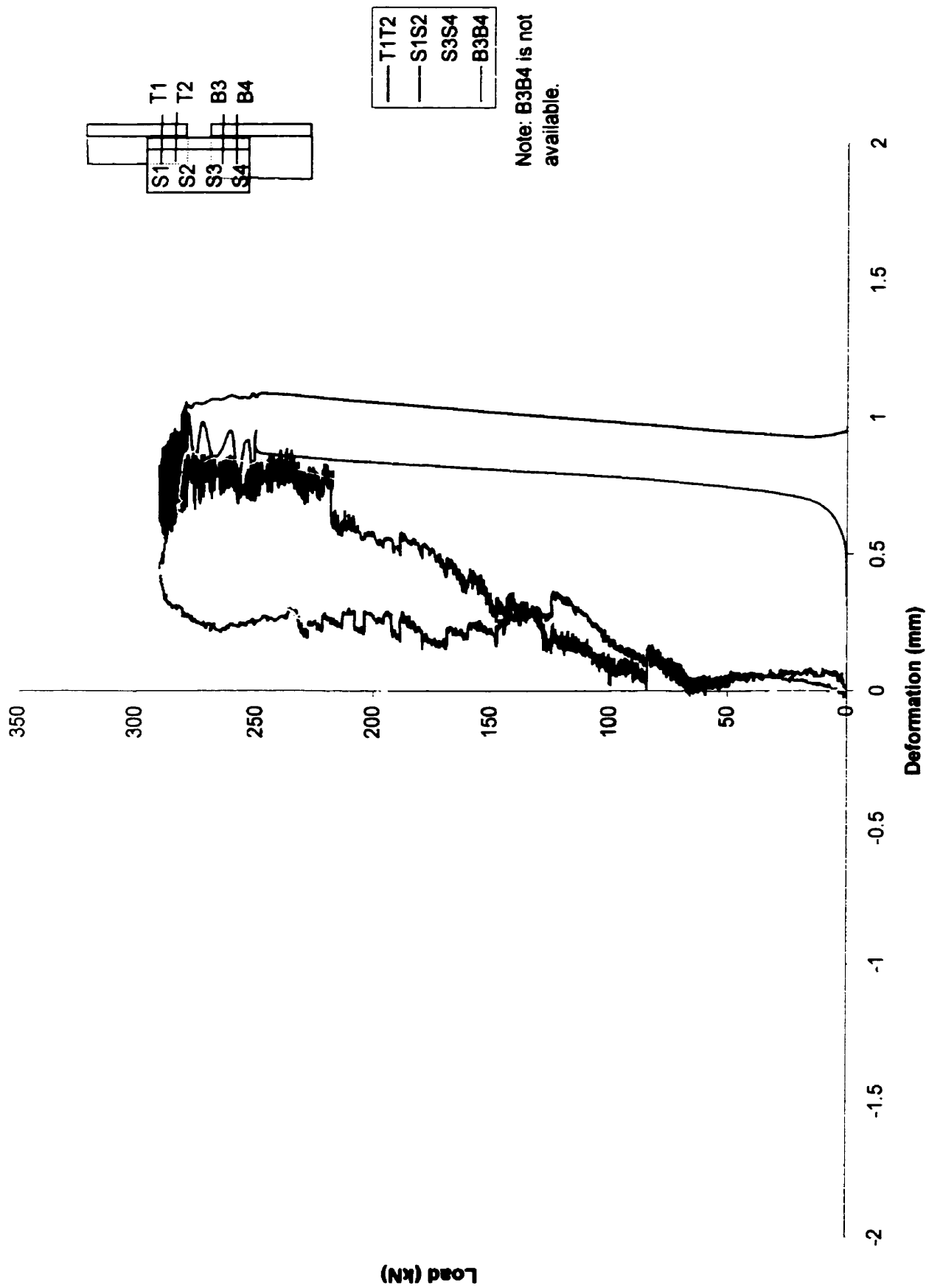
**Figure 4.11 Typical variations of load versus top joint deformation, bottom joint deformation, and total joint deformation of specimens with maximum construction clearance (3.18 mm) at assembly of Test Series A (Specimen AM1)**



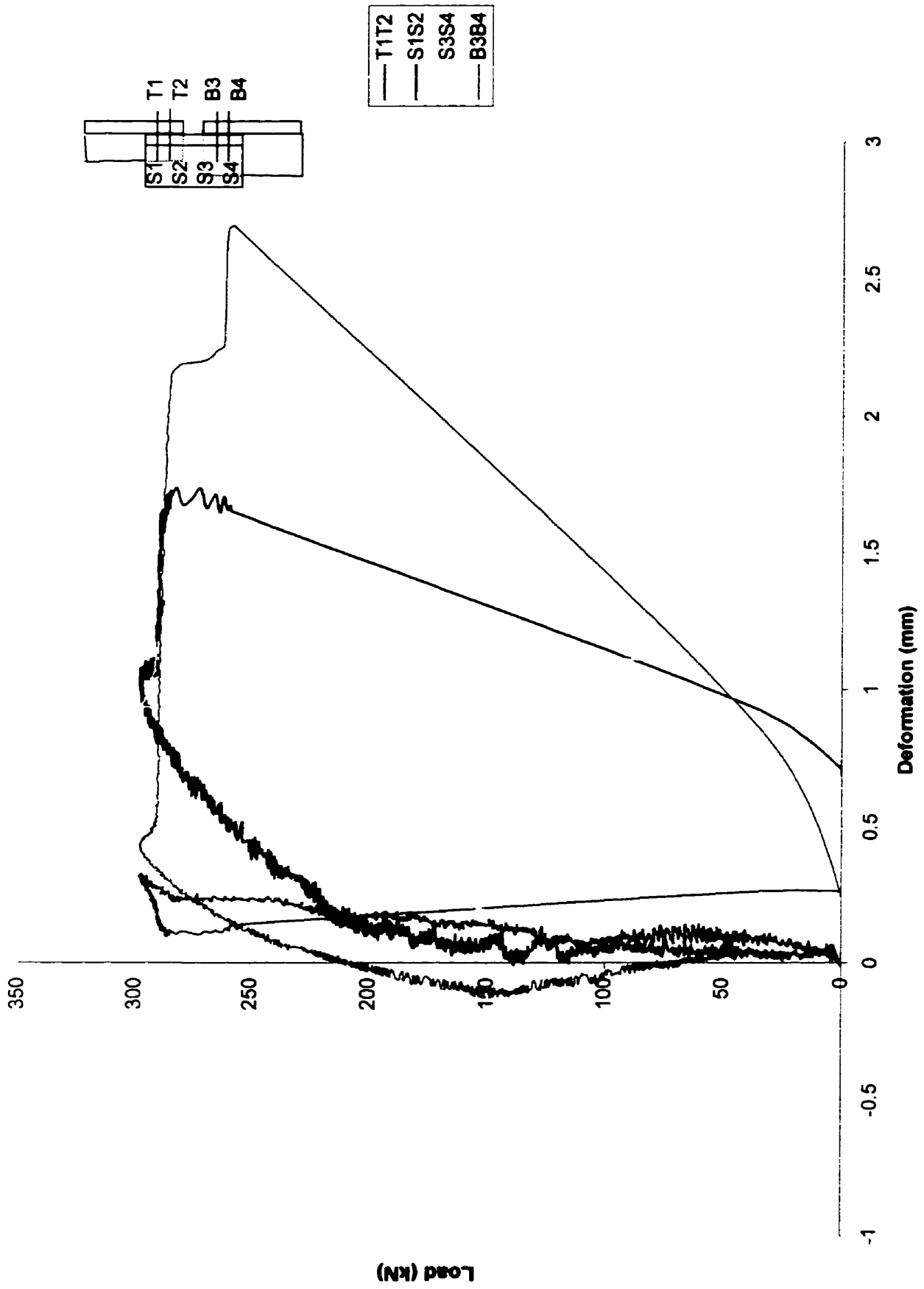
**Figure 4.12 Typical variations of load versus top joint deformation, bottom joint deformation, and total joint deformation of specimens with normal construction clearance (1.59 mm) at assembly of Test Series A (AN3)**



**Figure 4.13 Typical variations of load versus top joint deformation, bottom joint deformation, and total joint slip of specimens set in bearing at assembly on Test Series A (Specimen AB2)**



**Figure 4.14 Typical of variations of deformation of portions of top, bottom, and splice angle with load for joints with maximum construction clearance (3.18 mm) at assembly of Test Series A (Specimen AM3)**



**Figure 4.15** Typical variations of deformation of portions of top, bottom, and splice angle with load for joints with normal construction clearance (1.59 mm) at assembly of Test Series A (Specimen AN3)

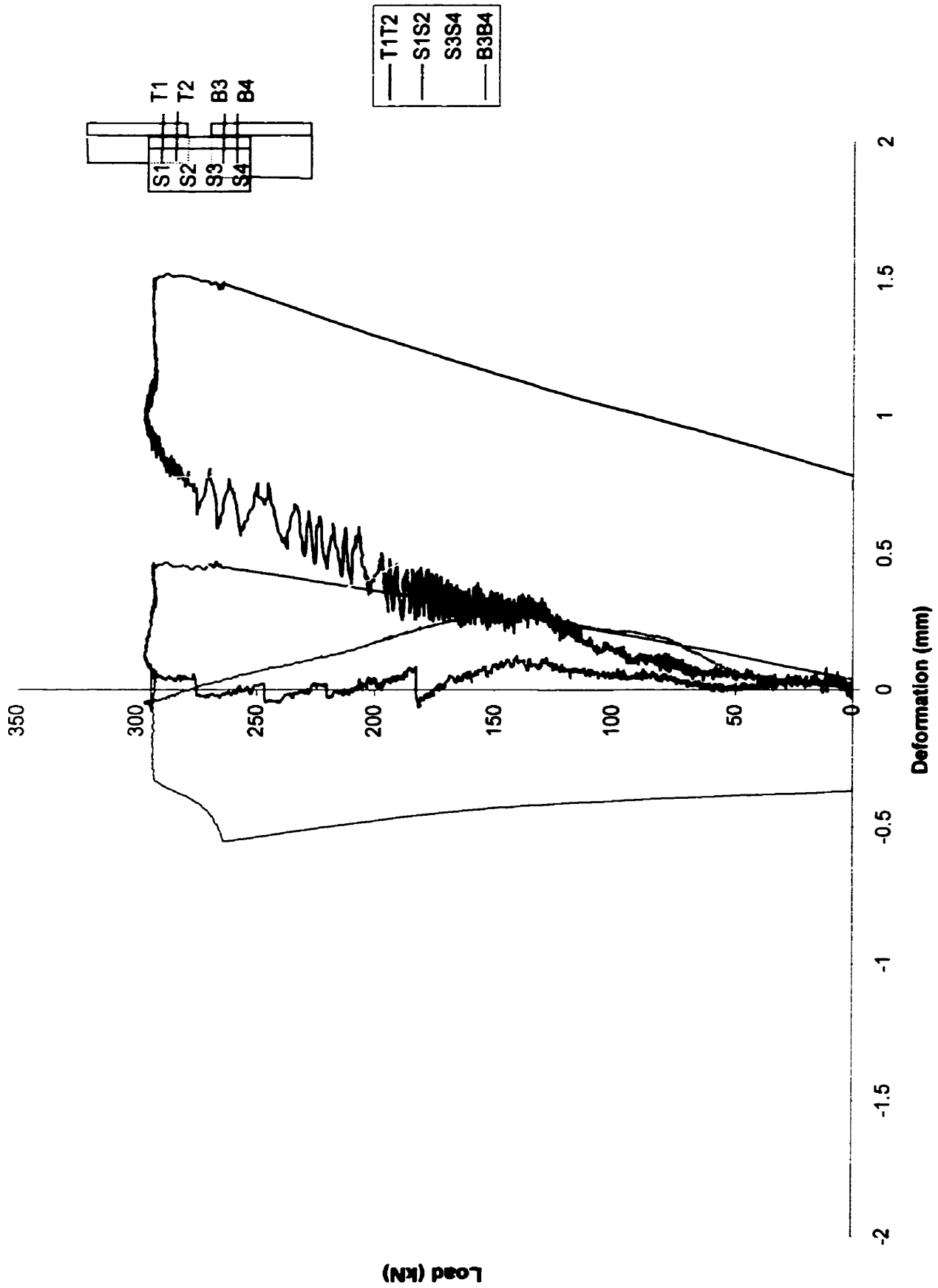
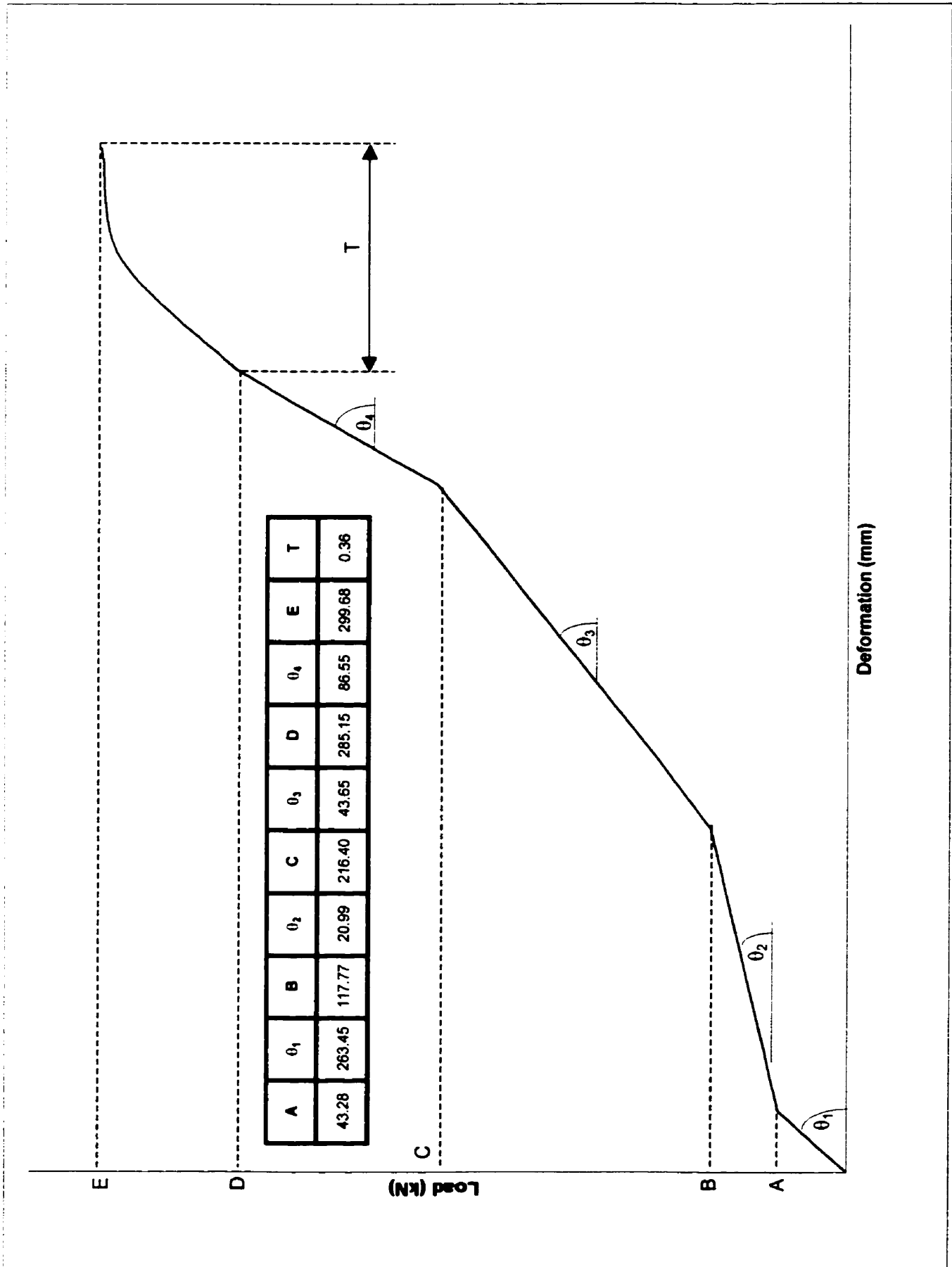
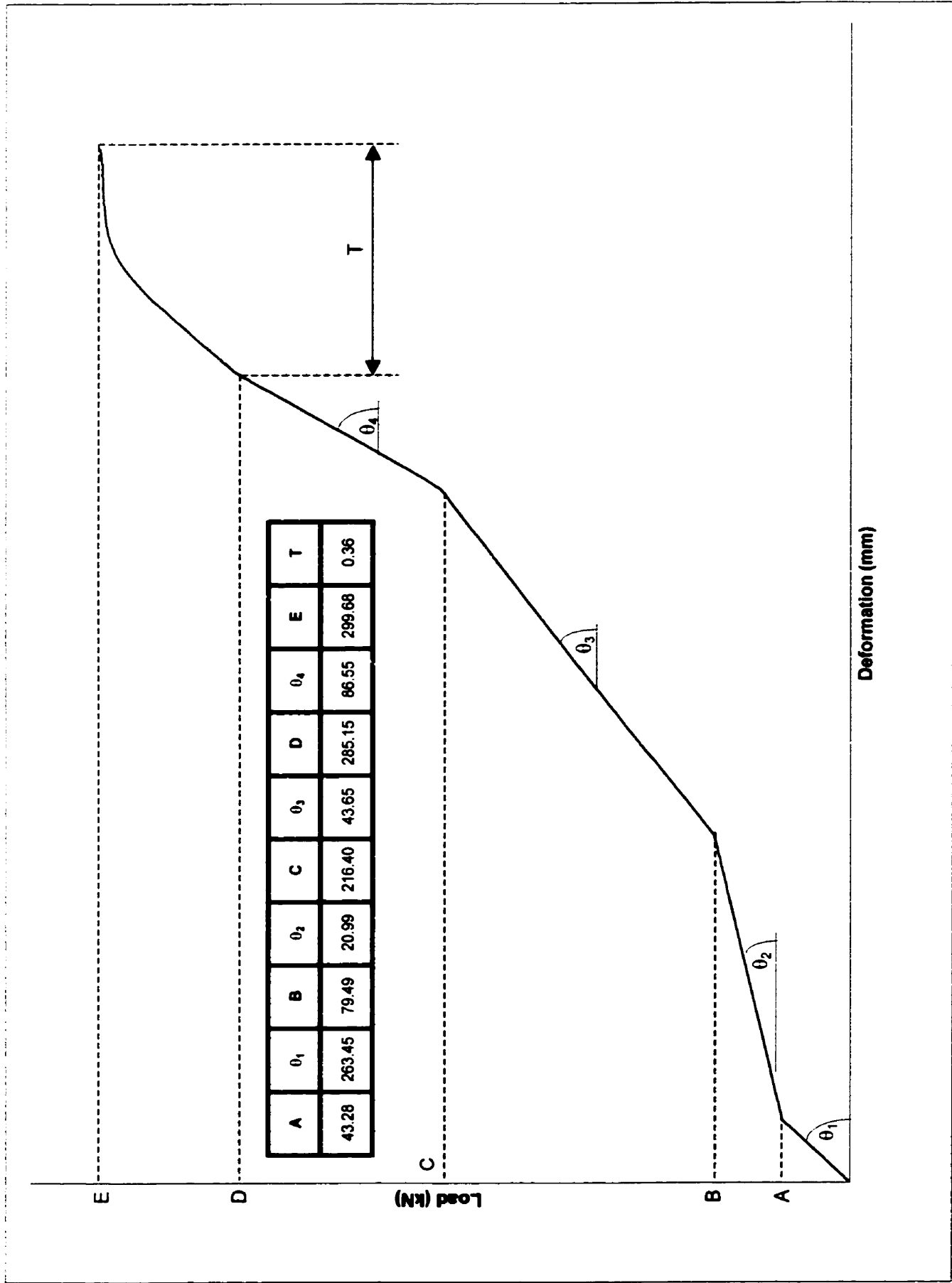


Figure 4.16 Typical variations of deformation of portions of top, bottom, and splice angle with load for joints set in bearing at assembly of Test Series A (Specimen AB2)





**Figure 4.17 Idealized load versus deformation diagram for joints with maximum construction clearance at assembly of Test Series A**



**Figure 4.18 Idealized load versus deformation diagram for joints with normal construction clearance at assembly of Test Series A**

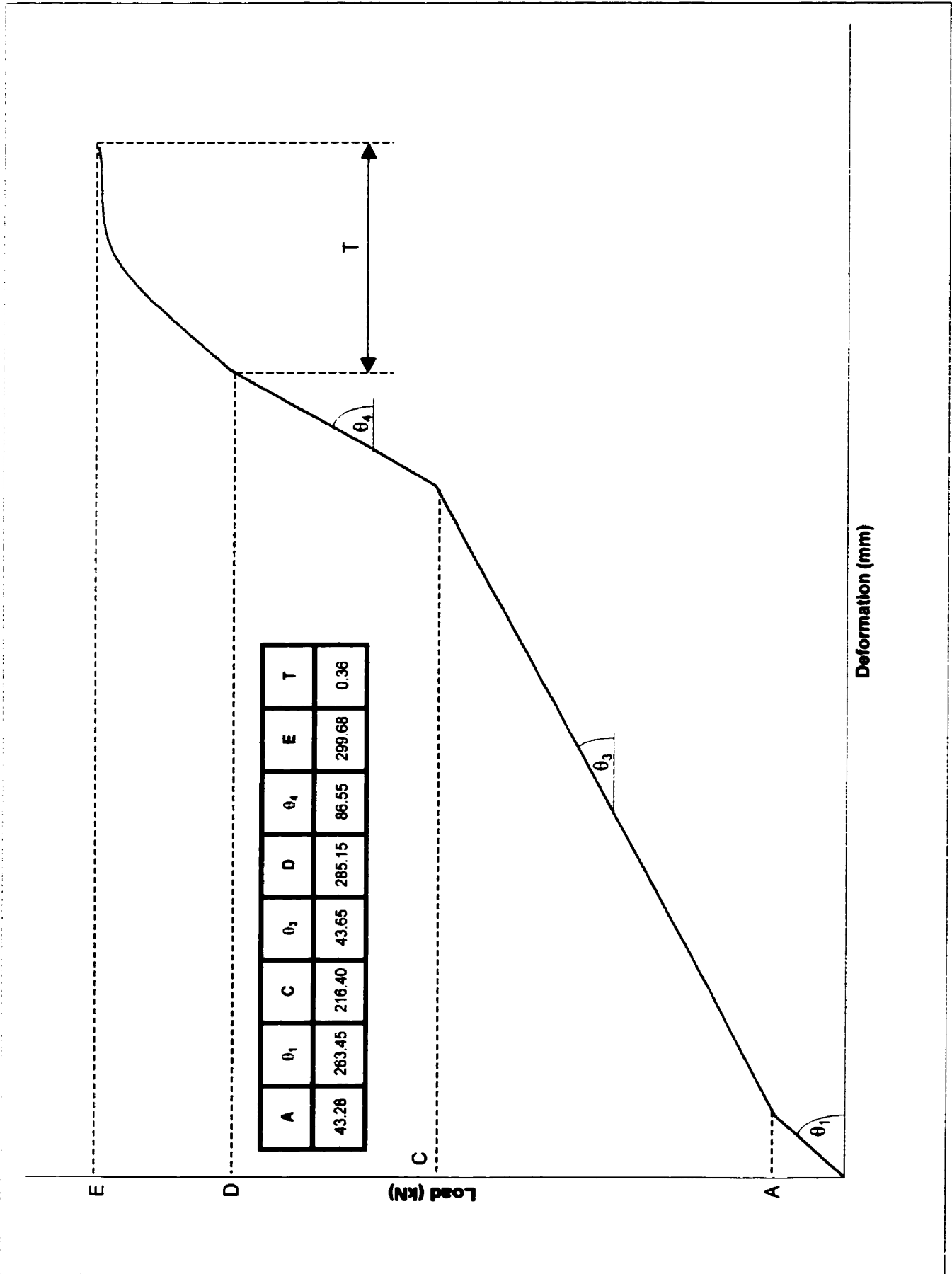


Figure 4.19 Idealized load versus deformation diagram for joints set in bearing at assembly of Test Series A

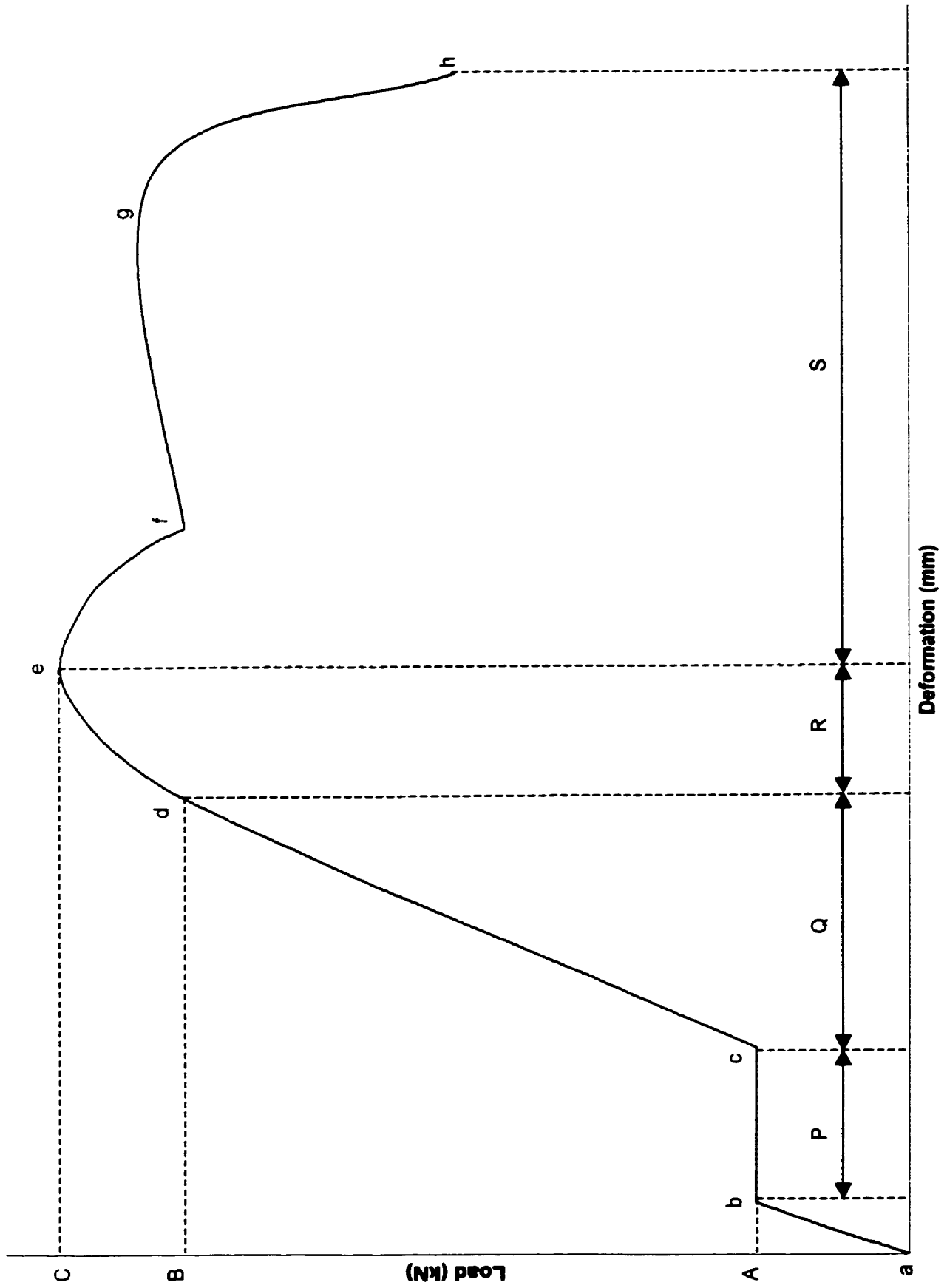
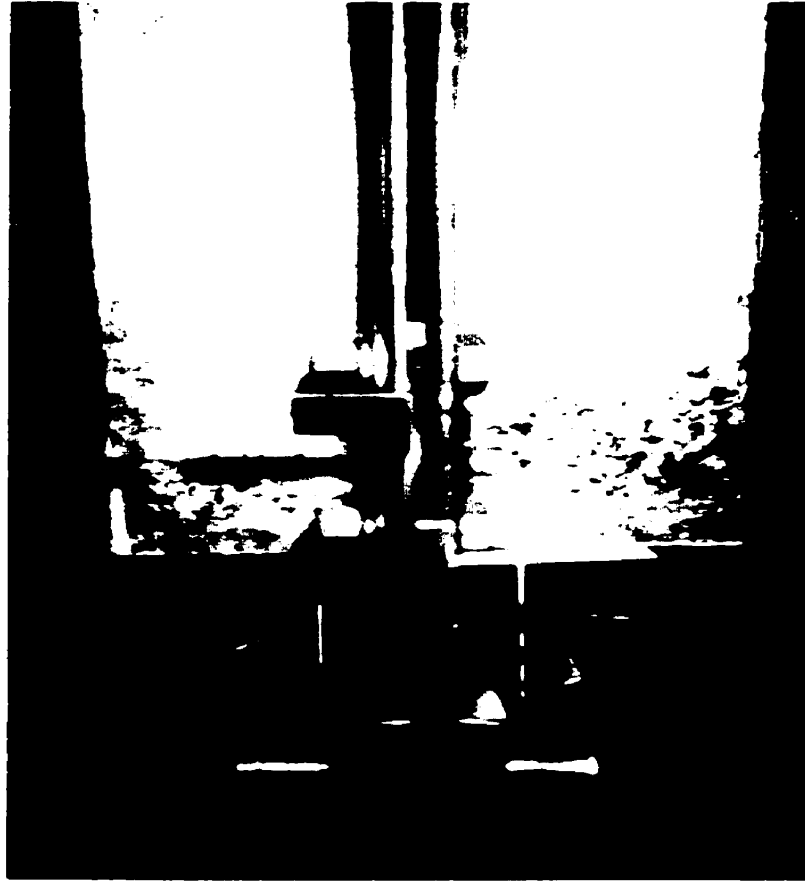
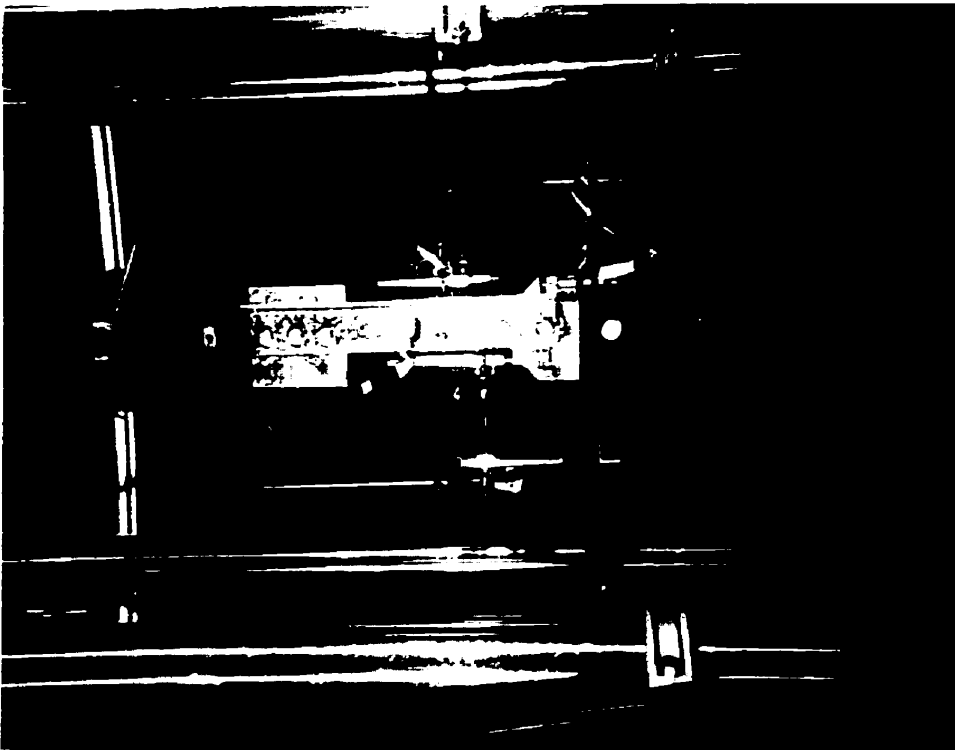


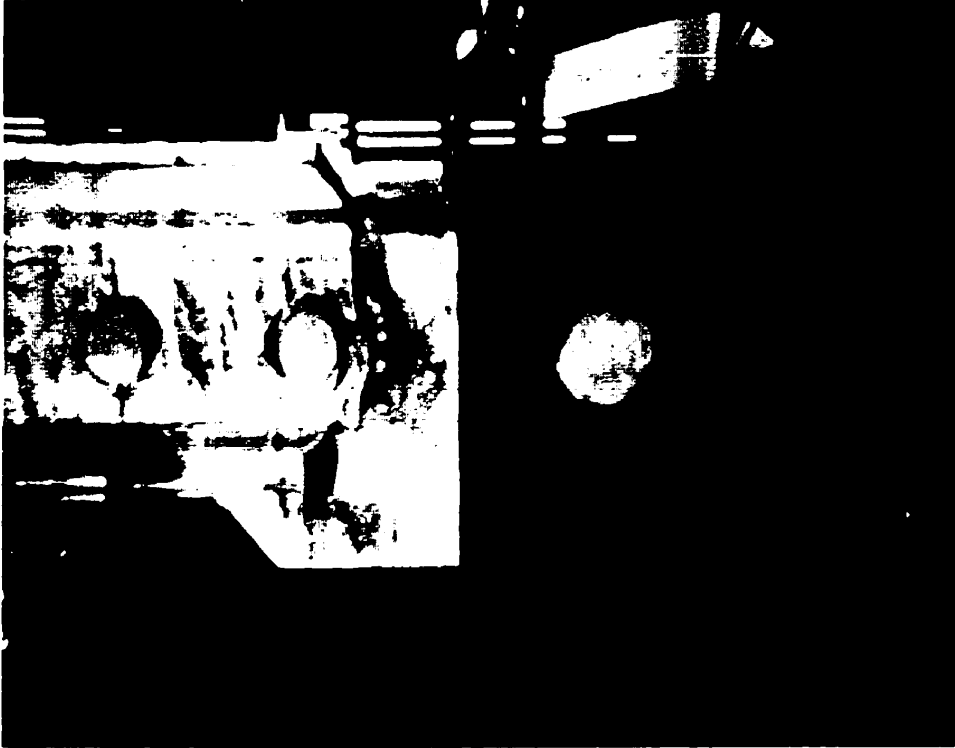
Figure 4.20 A typical load versus total joint deformation diagram for Test Series B



**Figure 4.21 Close up view of the crack on the gusset near its vertex**



4.22 (a)

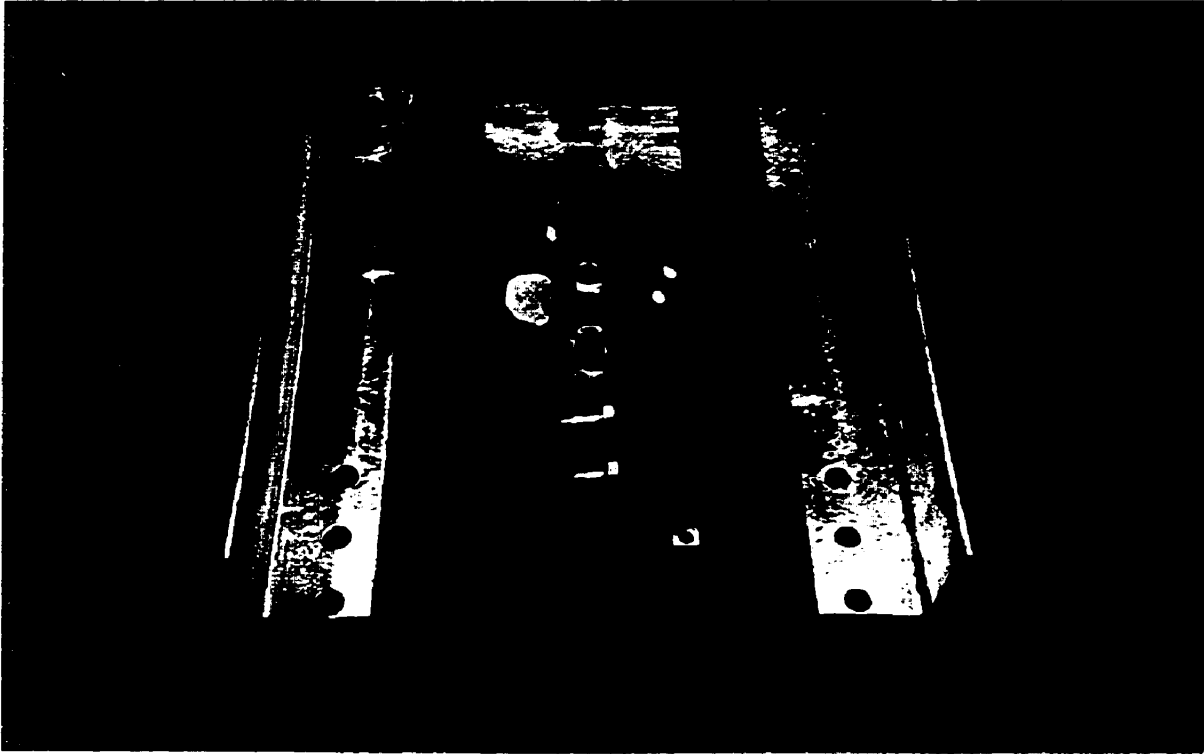


4.22 (b)

**Figure 4.22 Cracking of angles in progress during a test (a) and a close up view of a typical crack (b)**

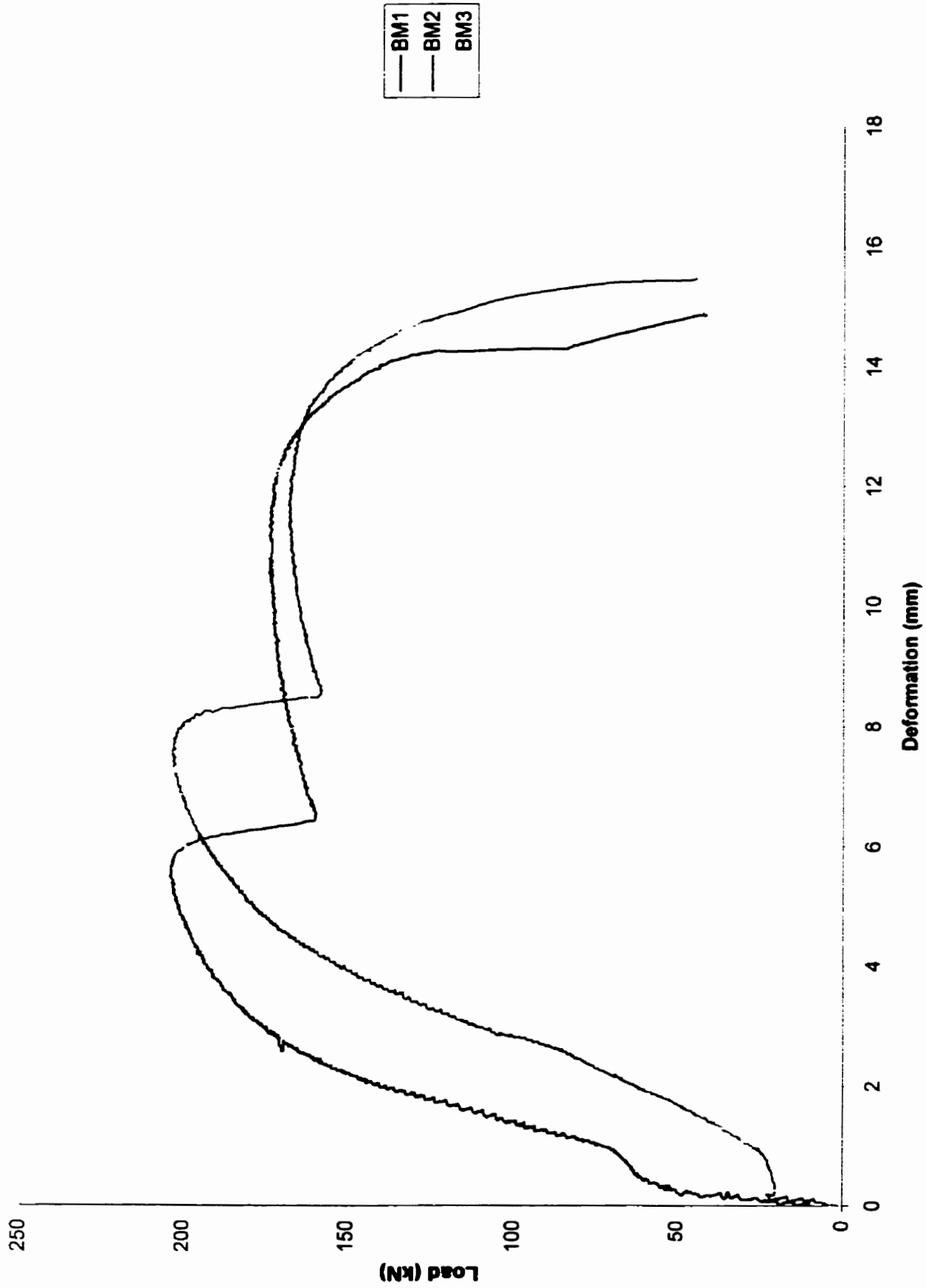


**Figure 4.23 Failure with the gusset near vertex cracking on one side followed by cracking of both angles at their ends**

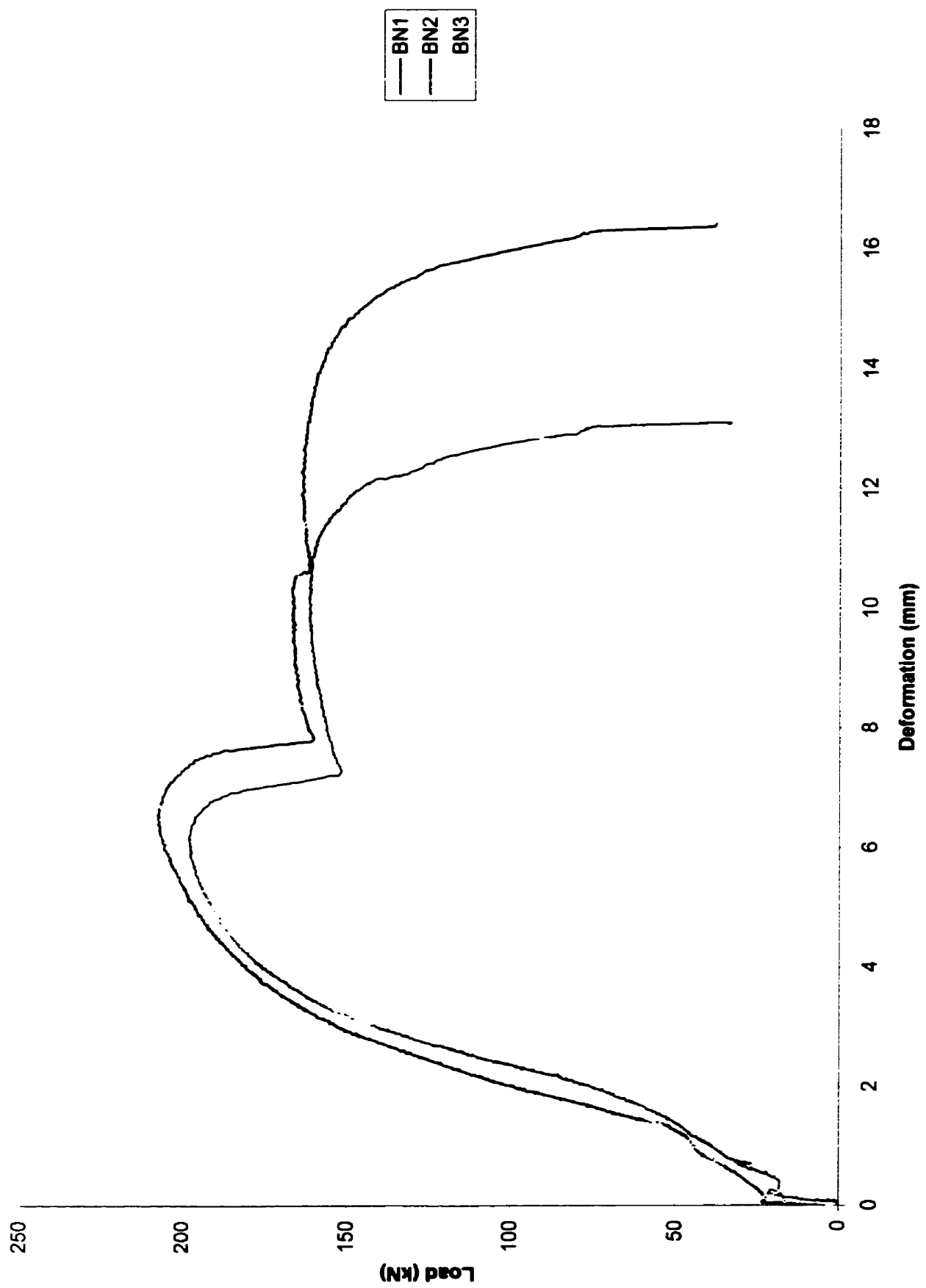


**Figure 4.24 Failure with the gusset near vertex cracking on both sides followed by cracking of two angles one after the other**

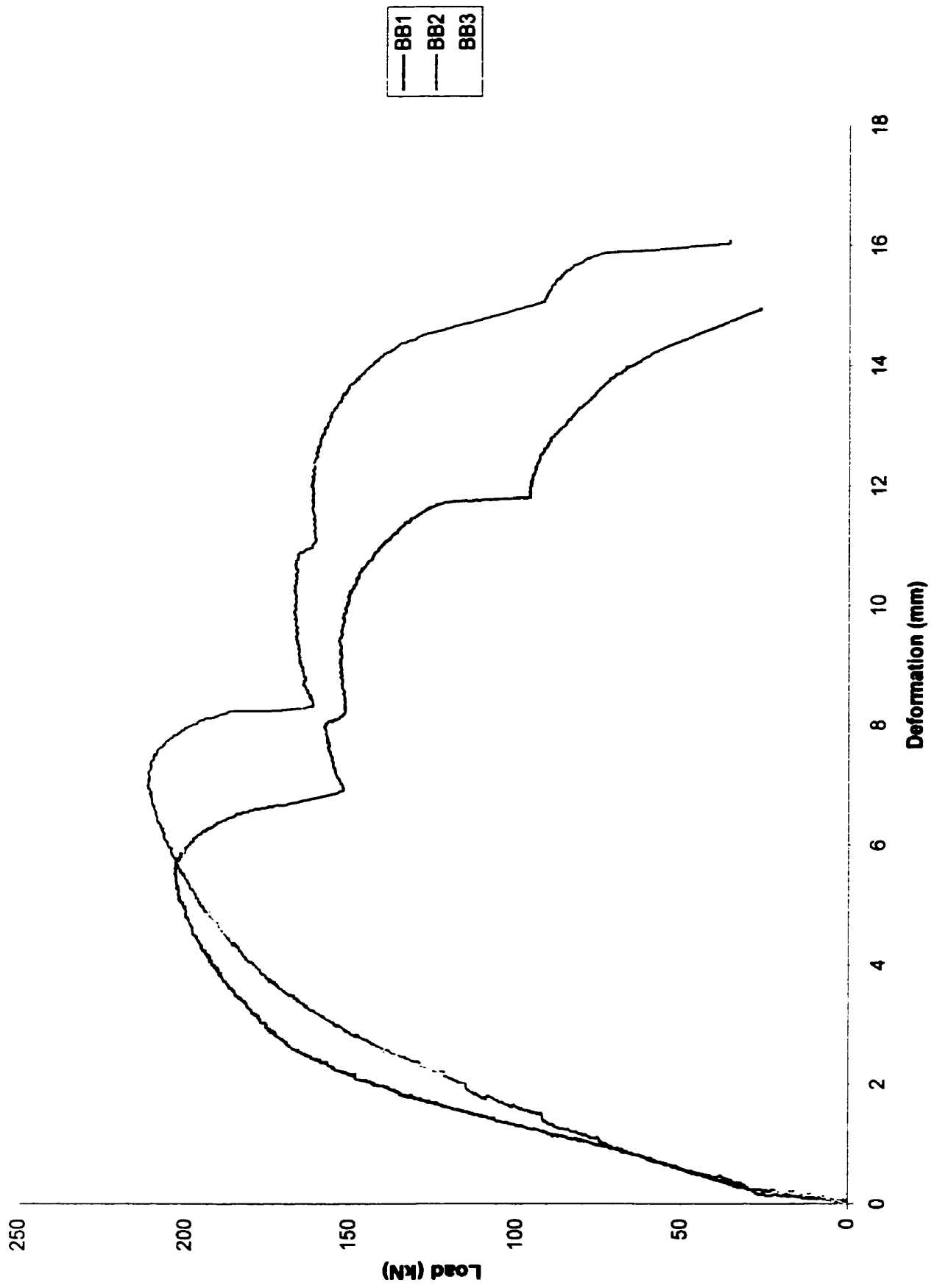




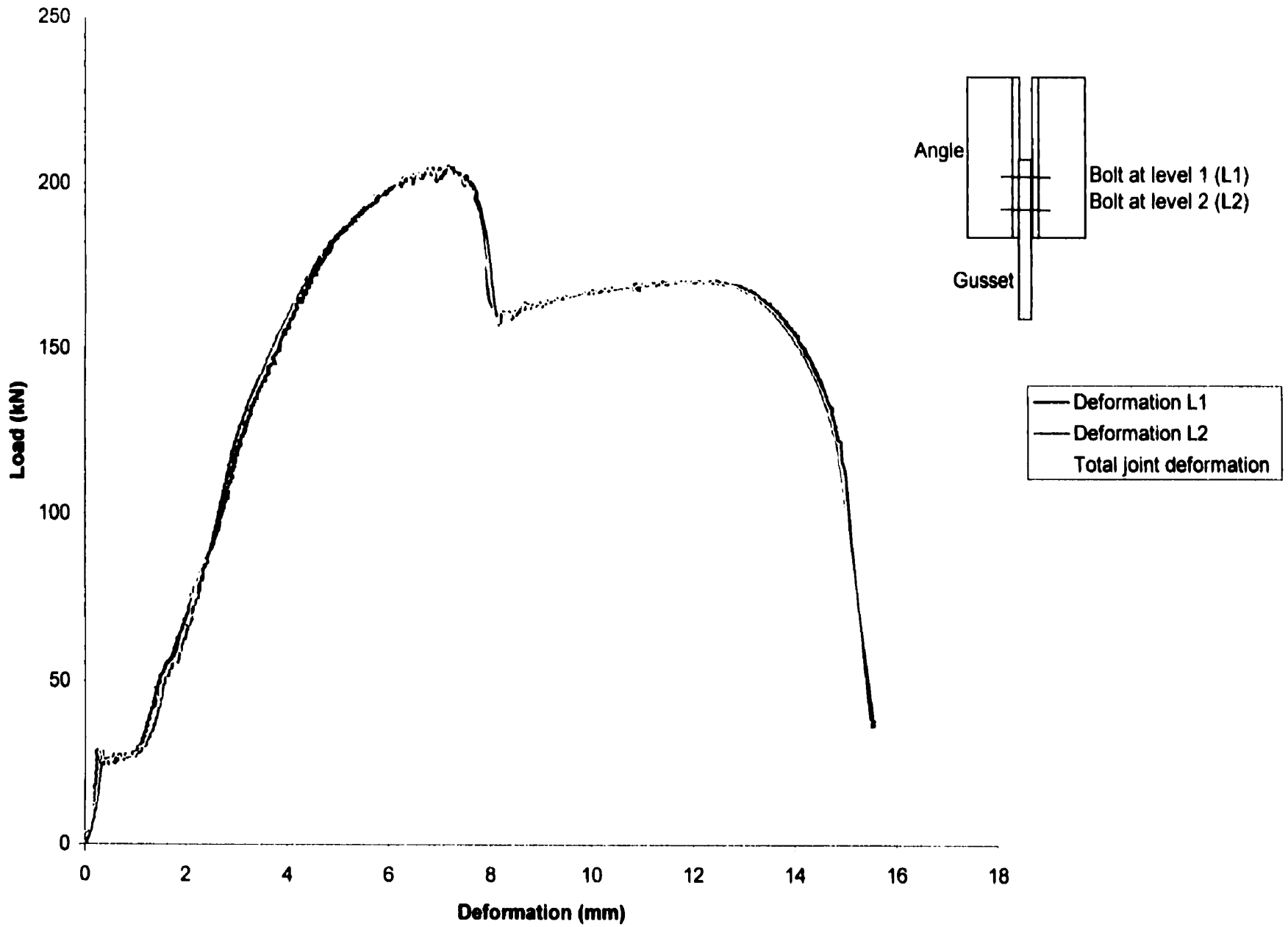
**Figure 4.25 Load versus total joint deformation diagrams for joints with maximum construction clearance (3.18 mm) at assembly of Test Series B**



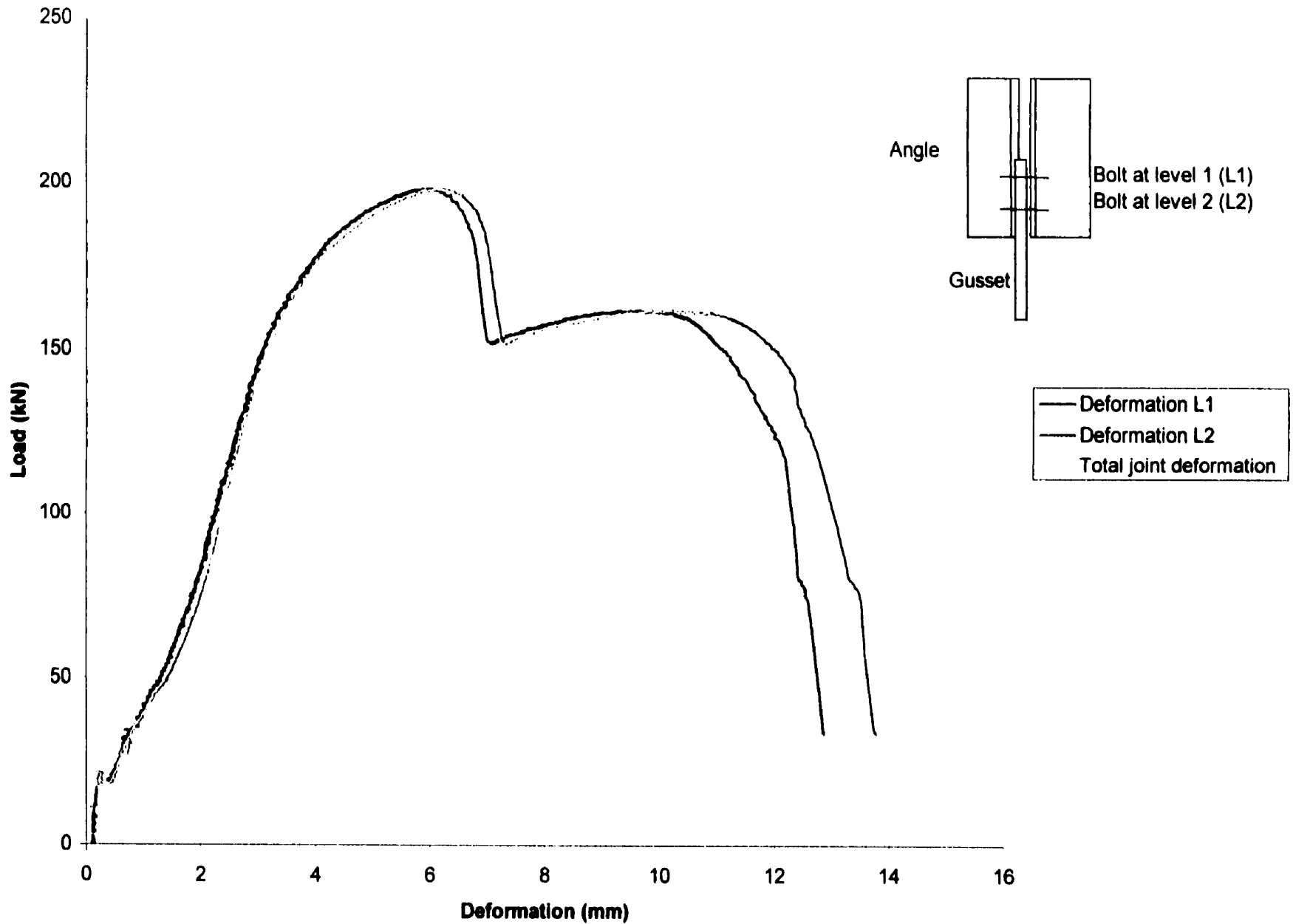
**Figure 4.26 Load versus total joint deformation diagrams for joints with normal construction clearance (1.59 mm) at assembly of Test Series B**



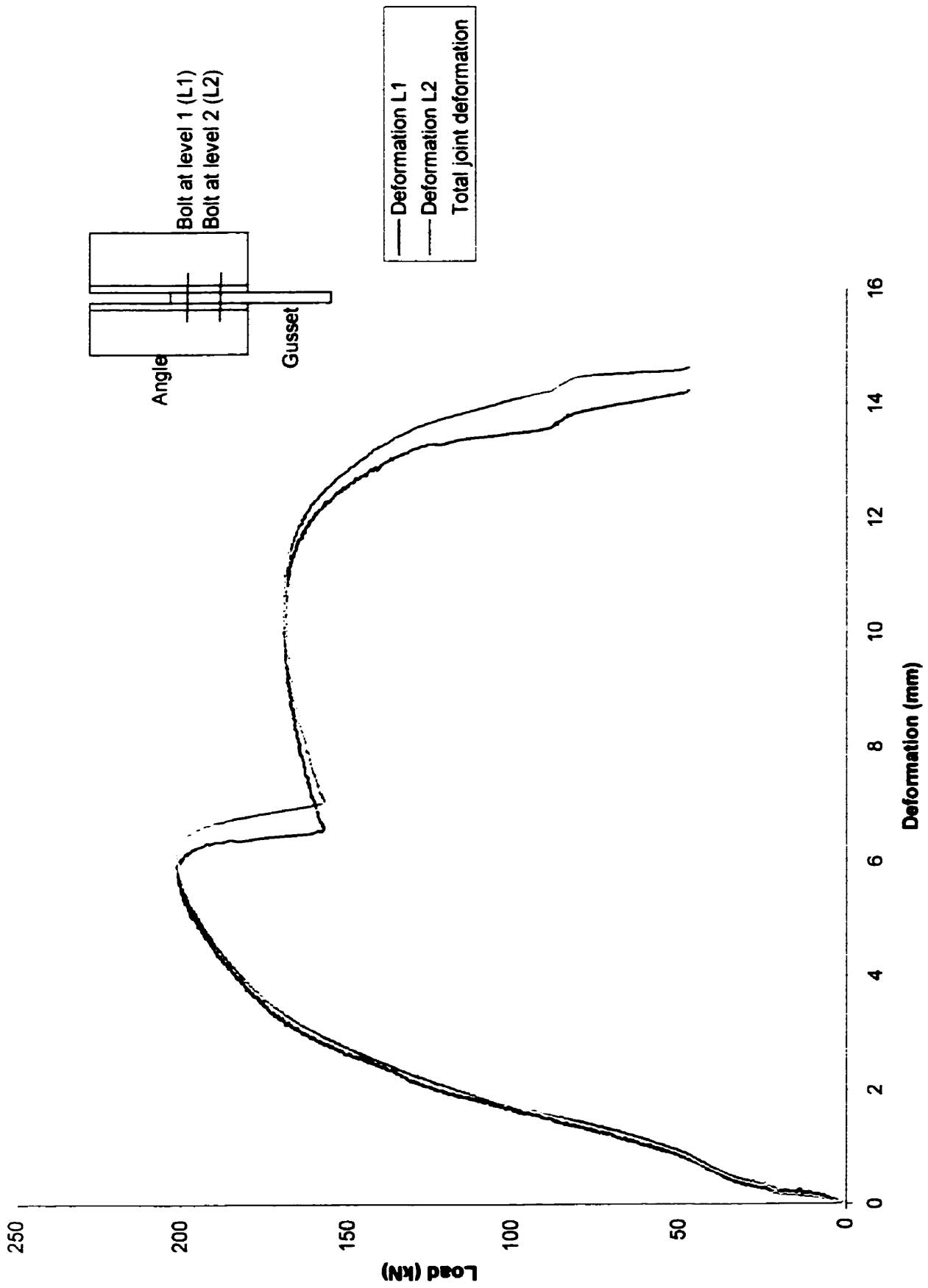
**Figure 4.27 Load versus total joint deformation diagrams for joints set in bearing at assembly of Test Series B**



**Figure 4.28 Typical variations of load with individual bolt deformation and total joint deformation of specimens with maximum construction clearance (3.18 mm) at assembly of Test Series B (Specimen BM3)**



**Figure 4.29 Typical variations of load with individual bolt deformation and total joint deformation of specimens with normal construction clearance (1.59 mm) at assembly of Test Series B (Specimen BN2)**



**Figure 4.30 Typical variations of load with individual bolt deformation and total joint deformation of specimens set in bearing at assembly of Test Series B (Specimen BB3)**

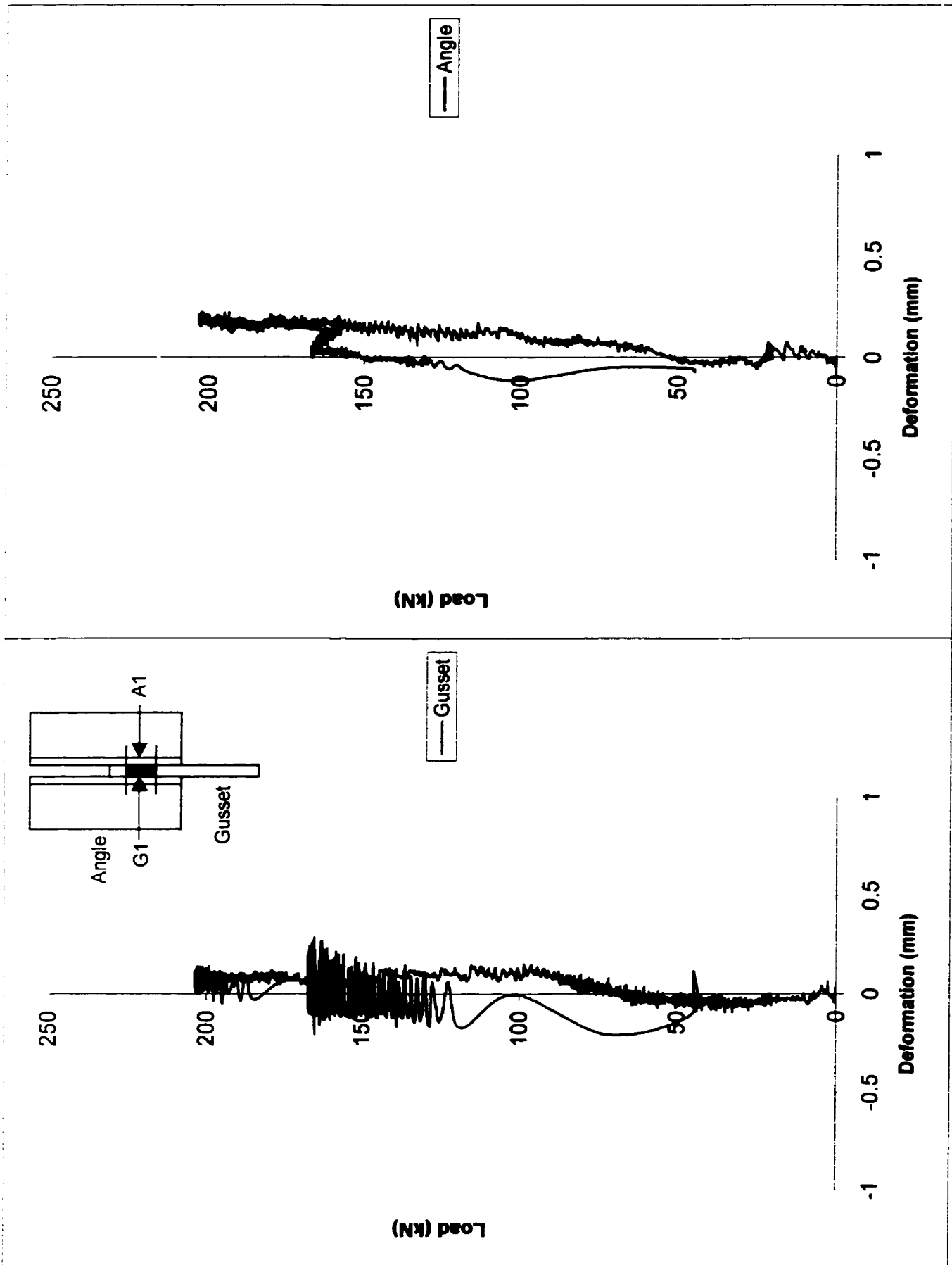


Figure 4.31 Load versus angle and gusset deformation (Specimen BM2)

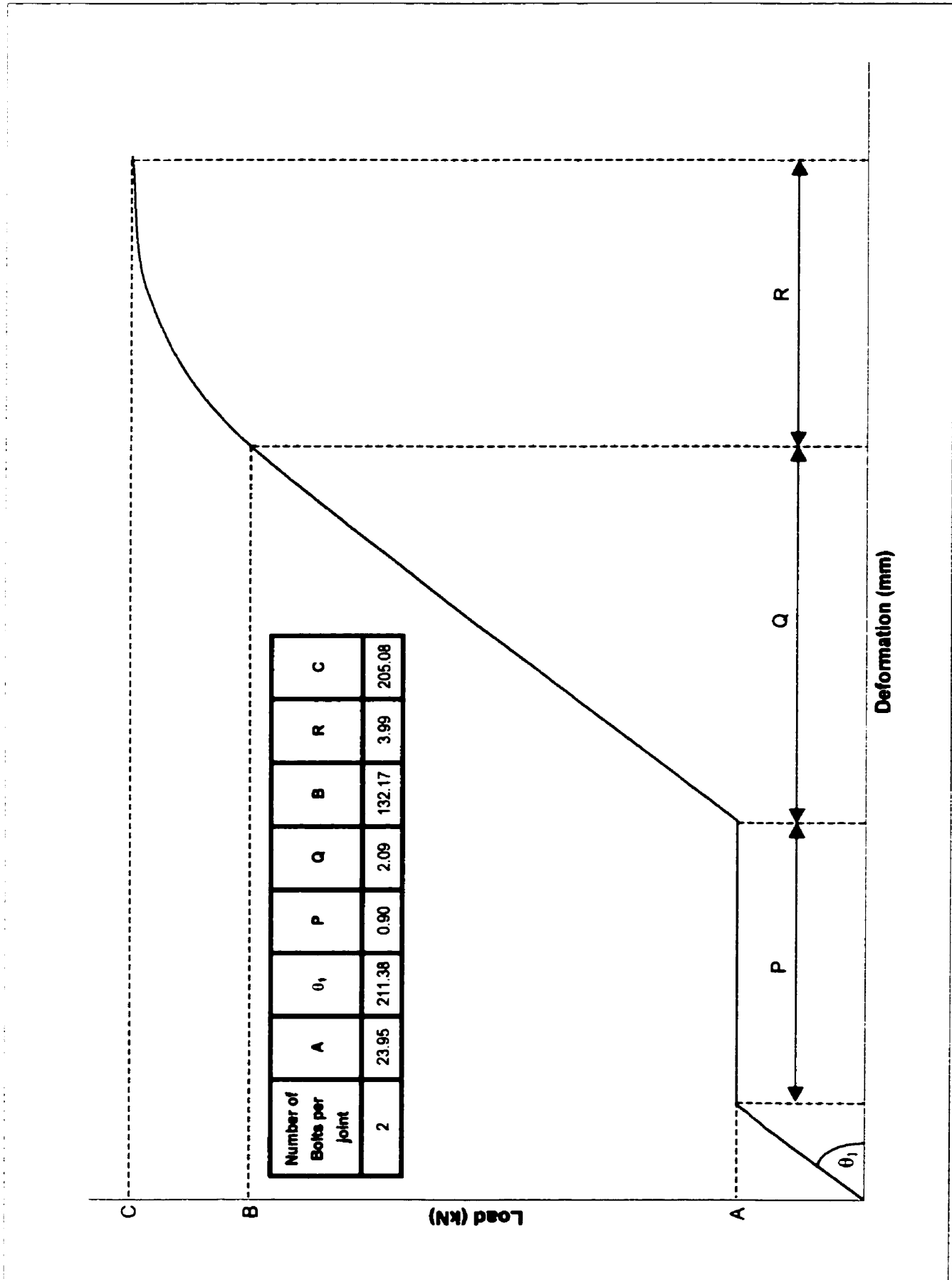
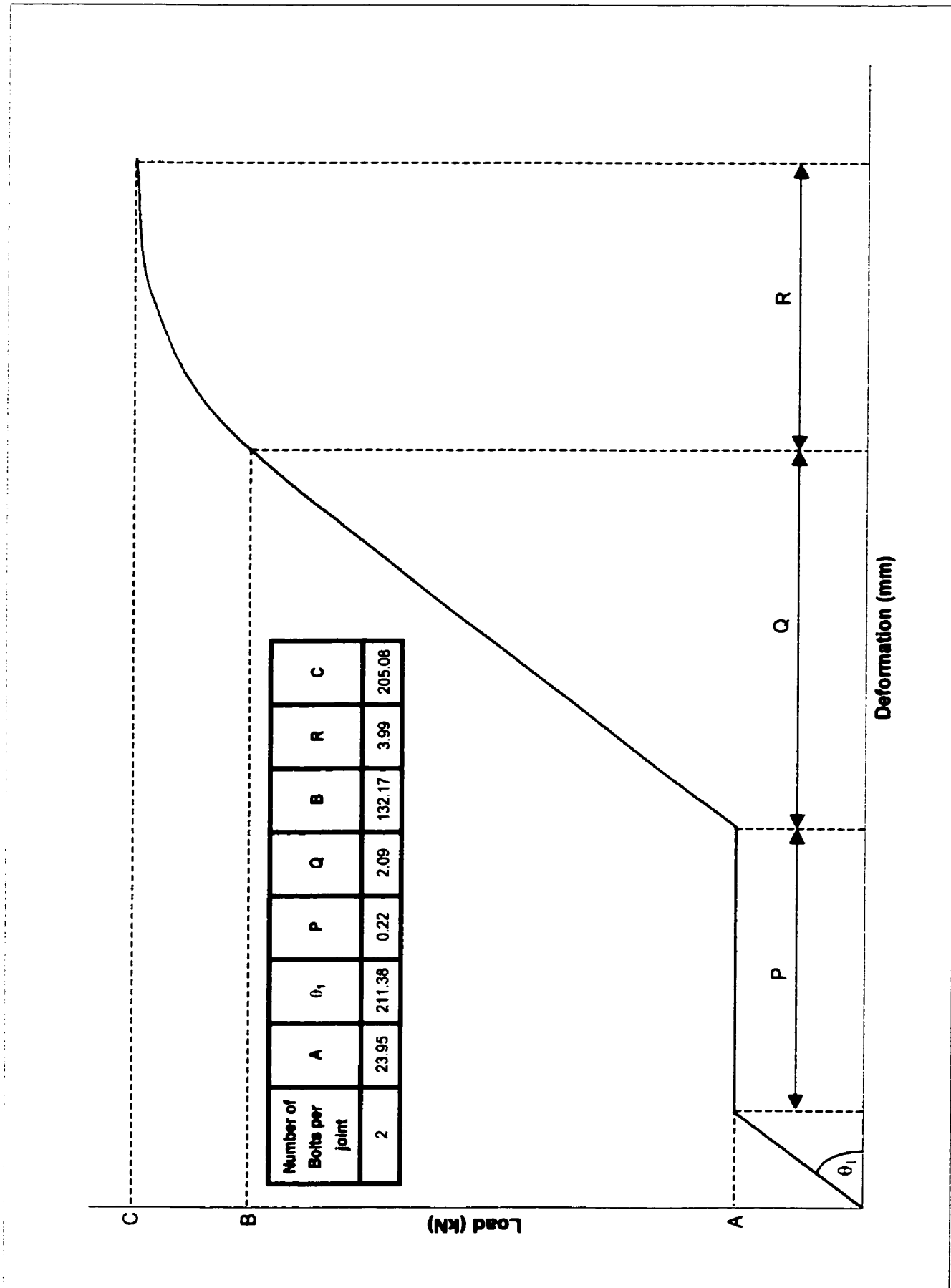


Figure 4.32 Idealized load versus deformation diagram for joints with maximum construction clearance at assembly of Test Series B





**Figure 4.33 Idealized load versus deformation diagram for joints with normal construction clearance at assembly of Test Series B**

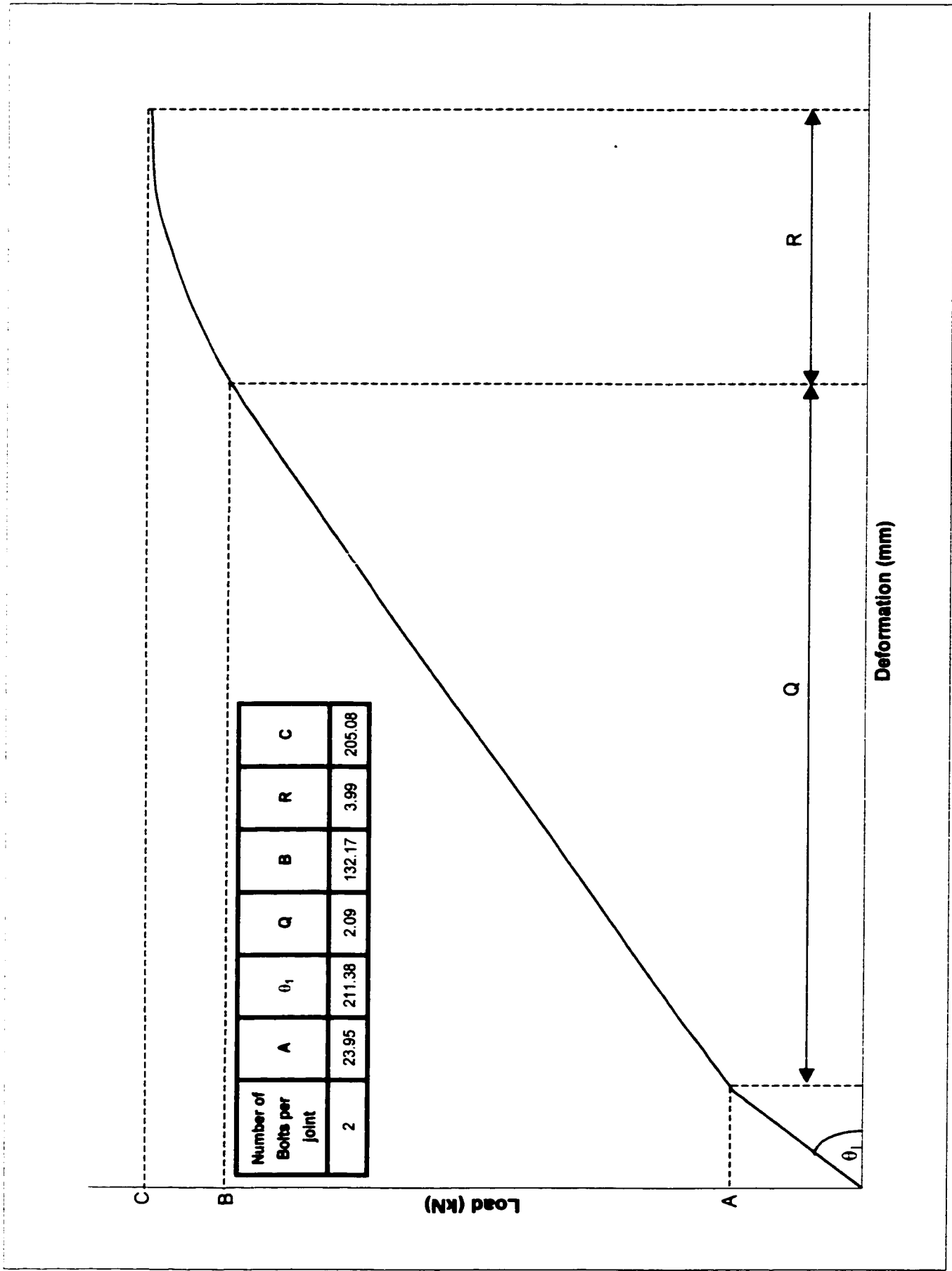
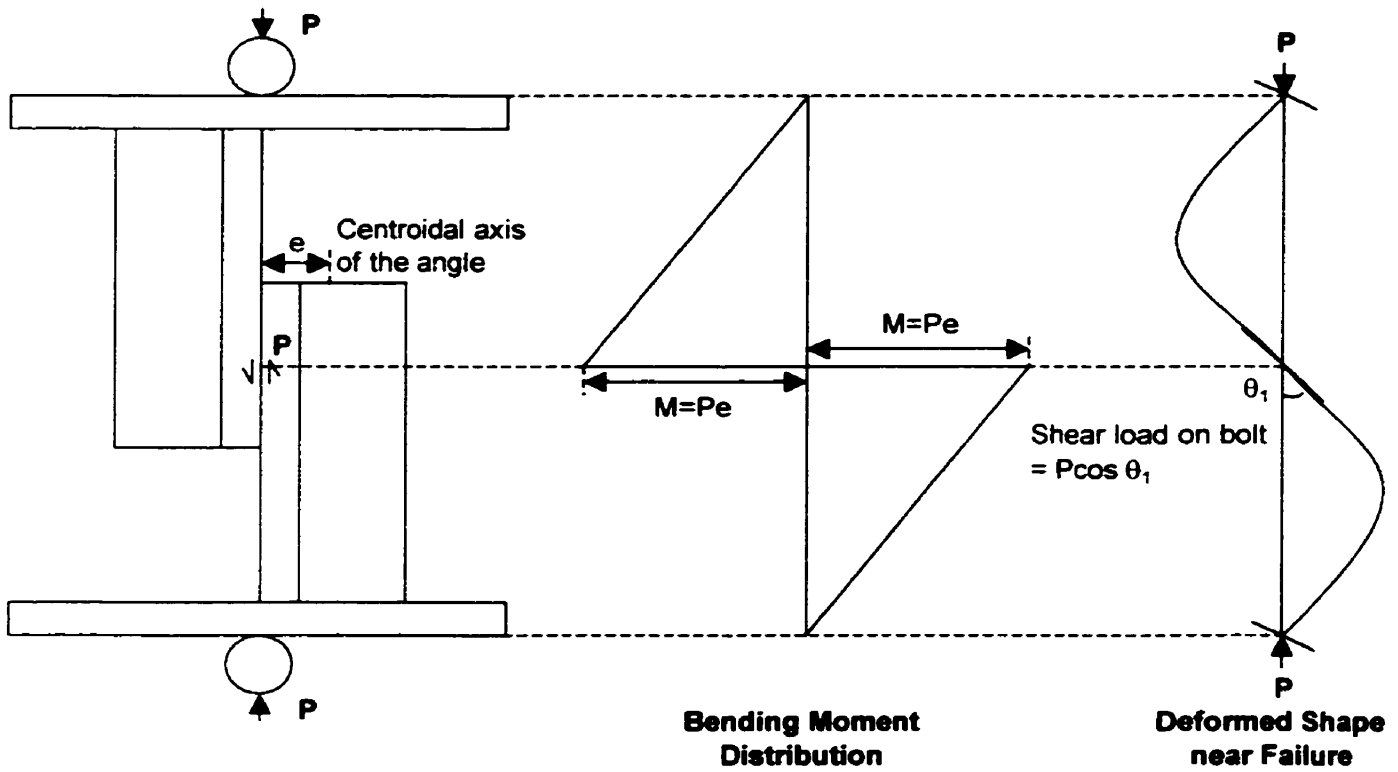
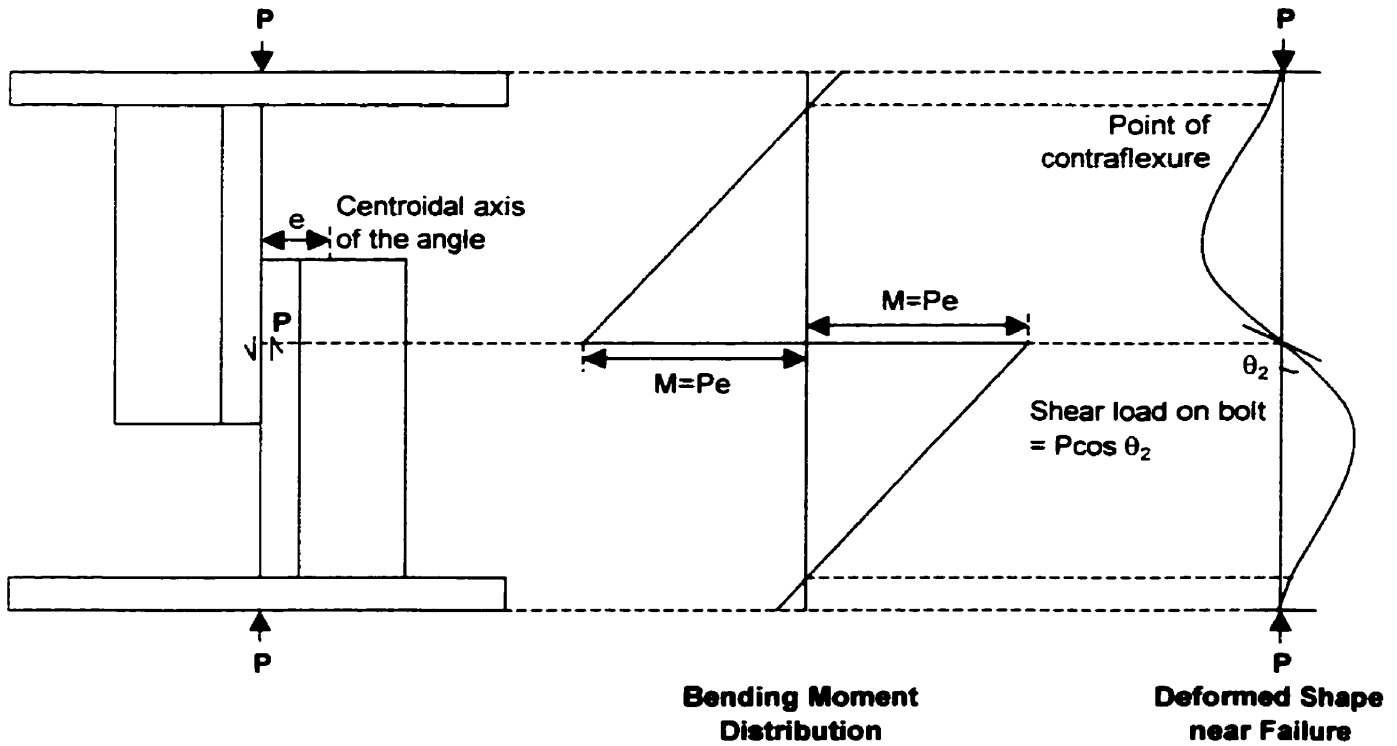


Figure 4.34 Idealized load versus deformation diagram for joints set in bearing at assembly of Test Series B



(a) Pinned End Conditions



(b) Fixed End Conditions

Note: As  $\theta_1 > \theta_2$ , therefore bolt shear load in case (a) < bolt shear load in case (b)

Figure 4.35 Effect of specimen end conditions on bolt shear

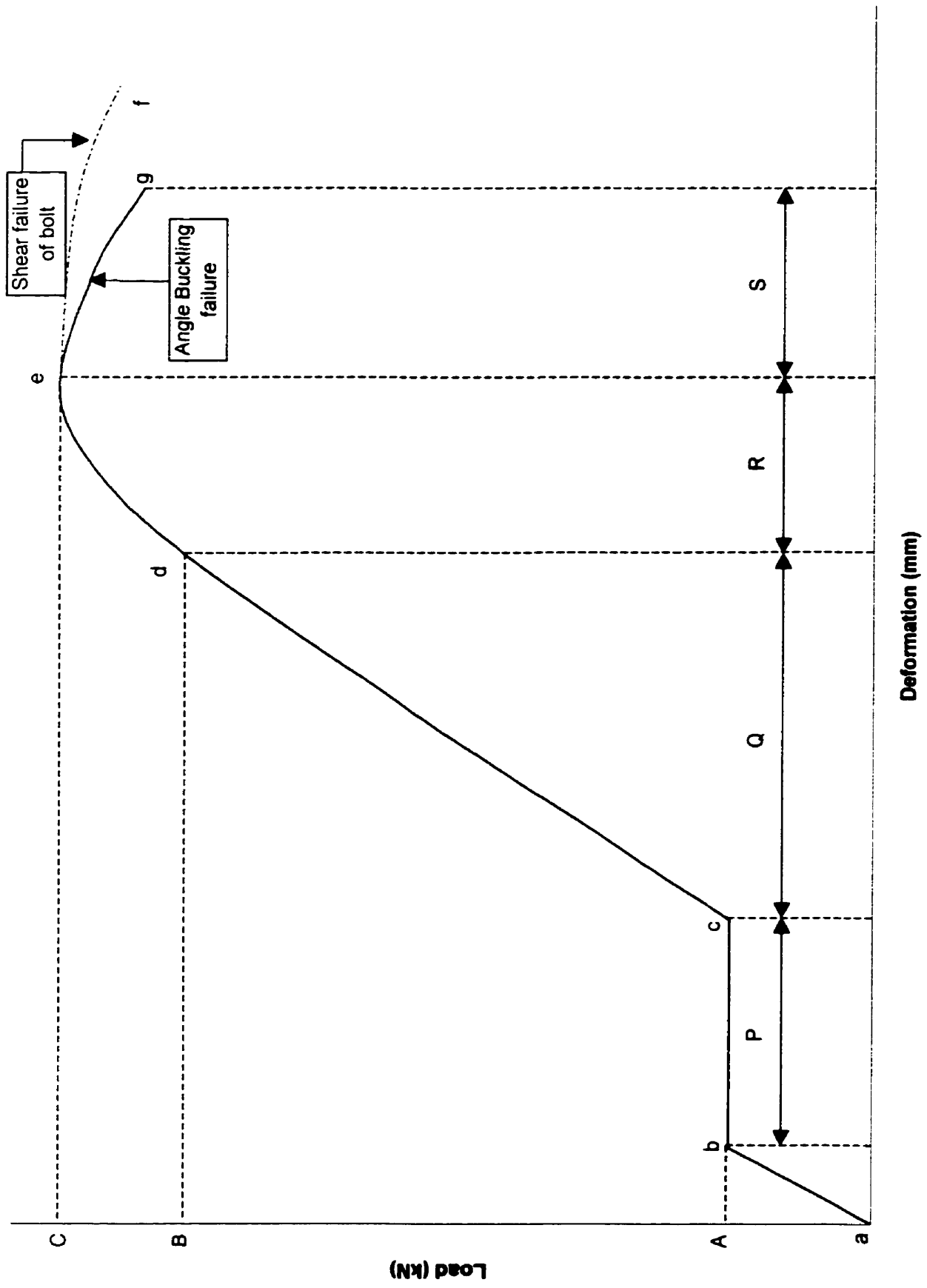
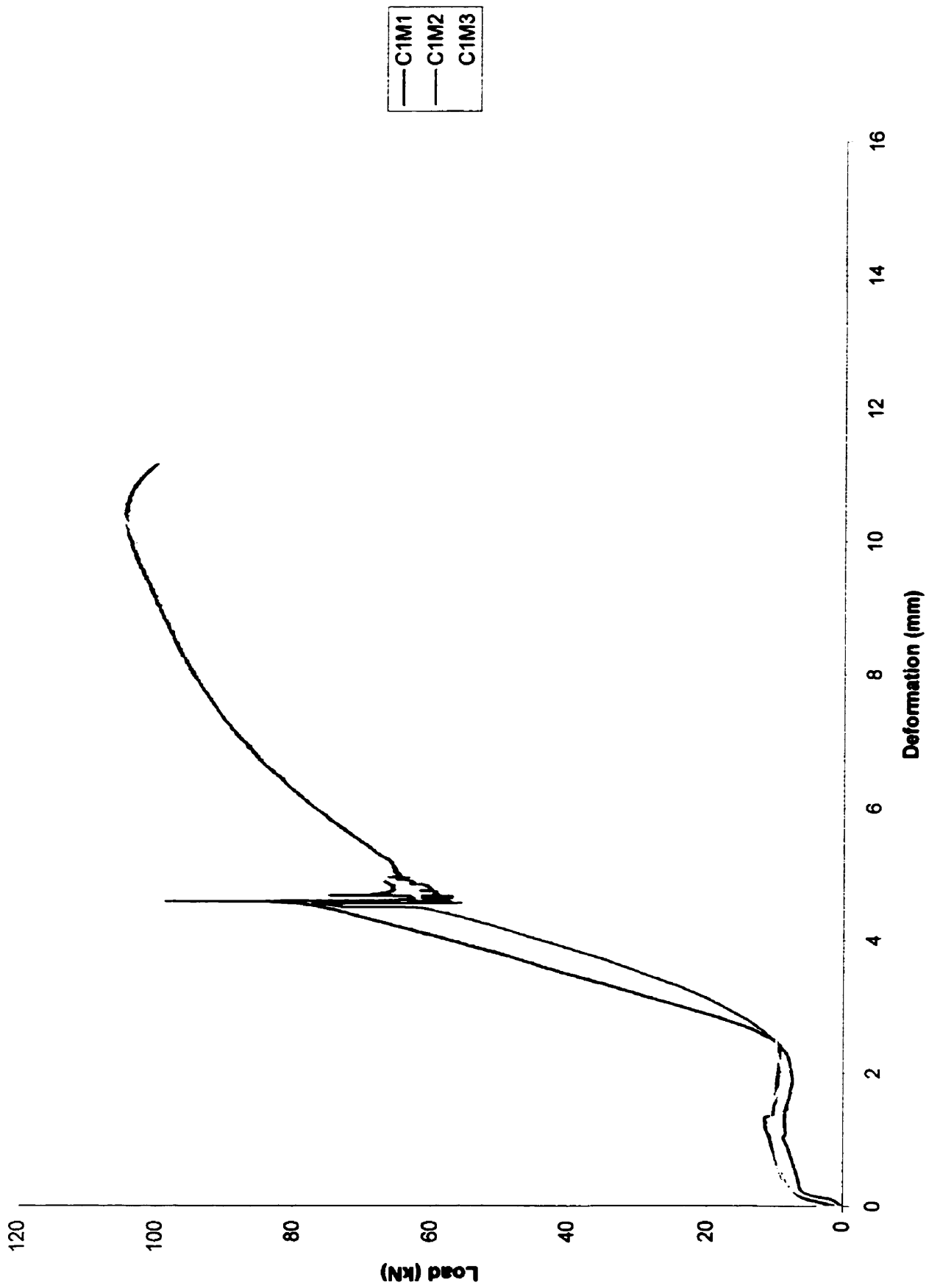
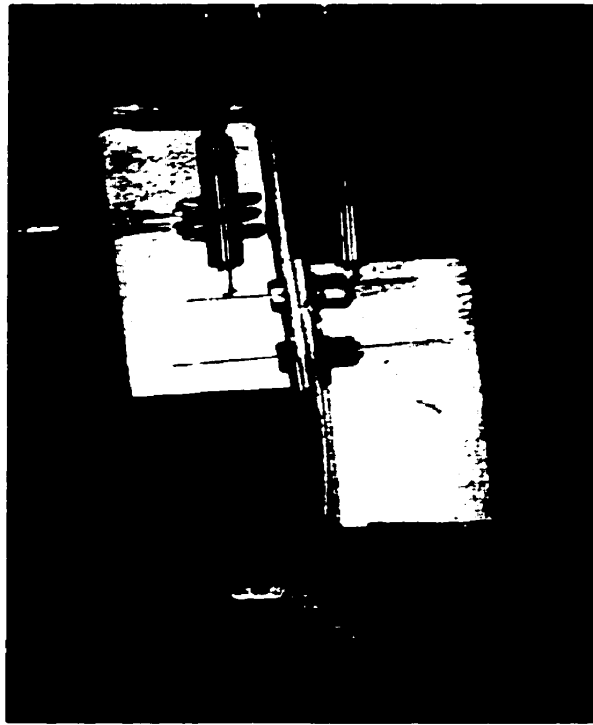


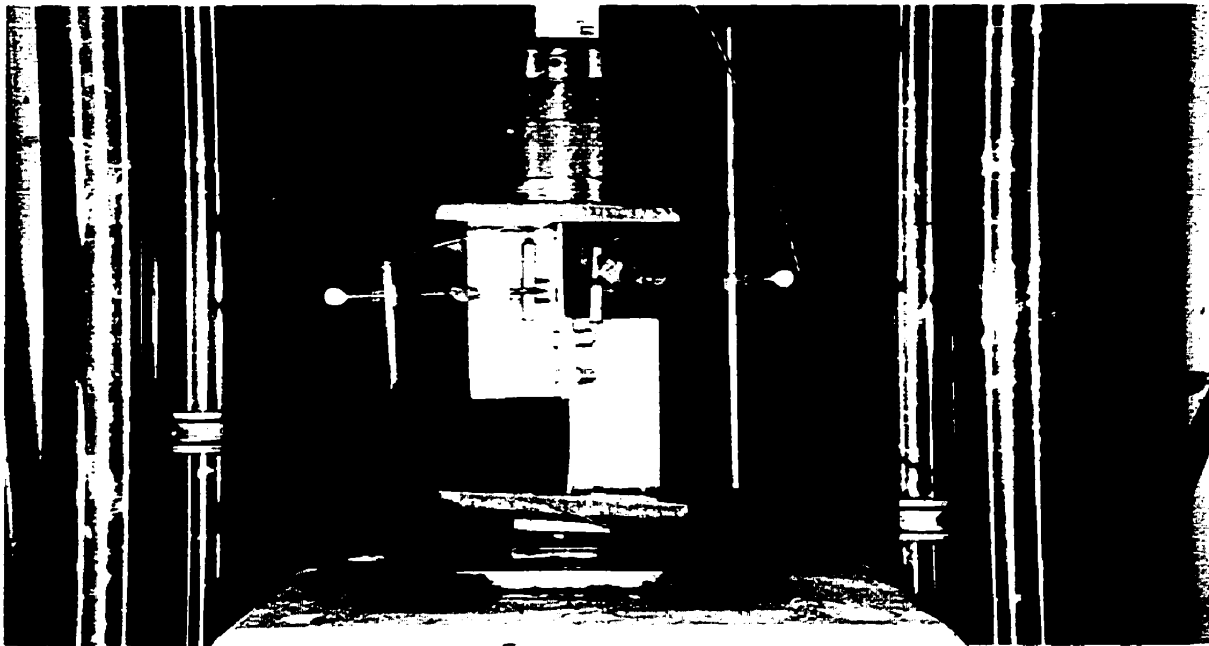
Figure 4.36 A typical load versus total joint deformation diagram for Test Series C



**Figure 4.37 Load versus total joint deformation diagrams for single bolted joints with maximum construction clearance (3.18 mm) at assembly of Test Series C**



(a)

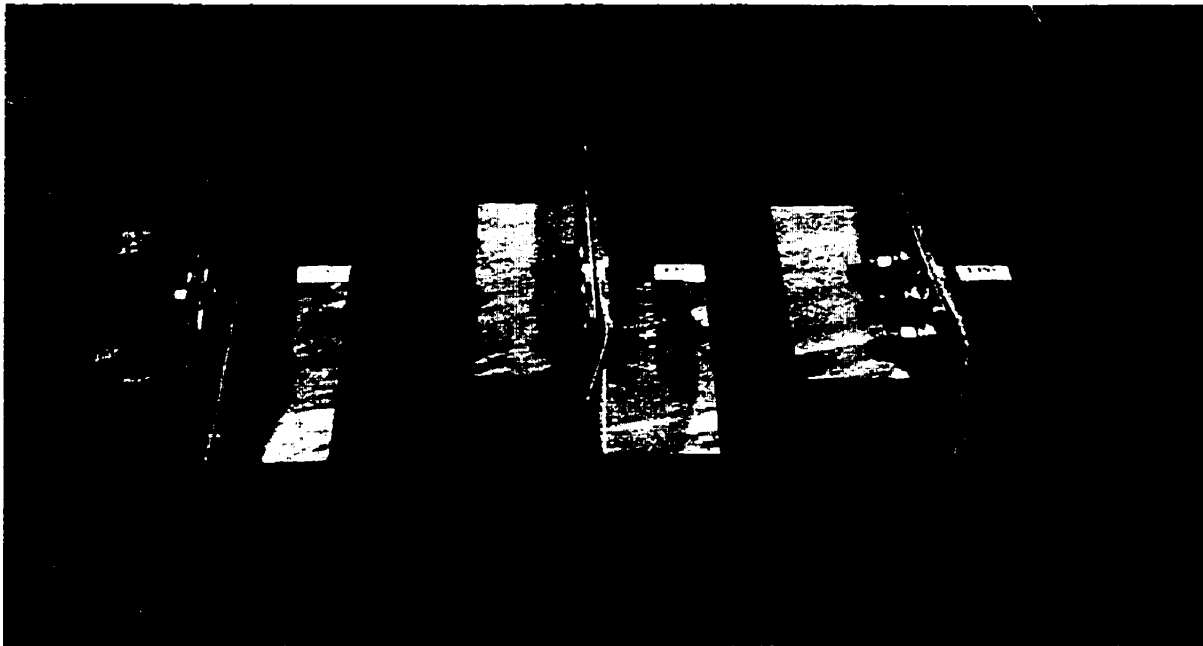


(b)

**Figure 4.38 Typical failure mode of specimens with 2 bolts (Test Series C)**

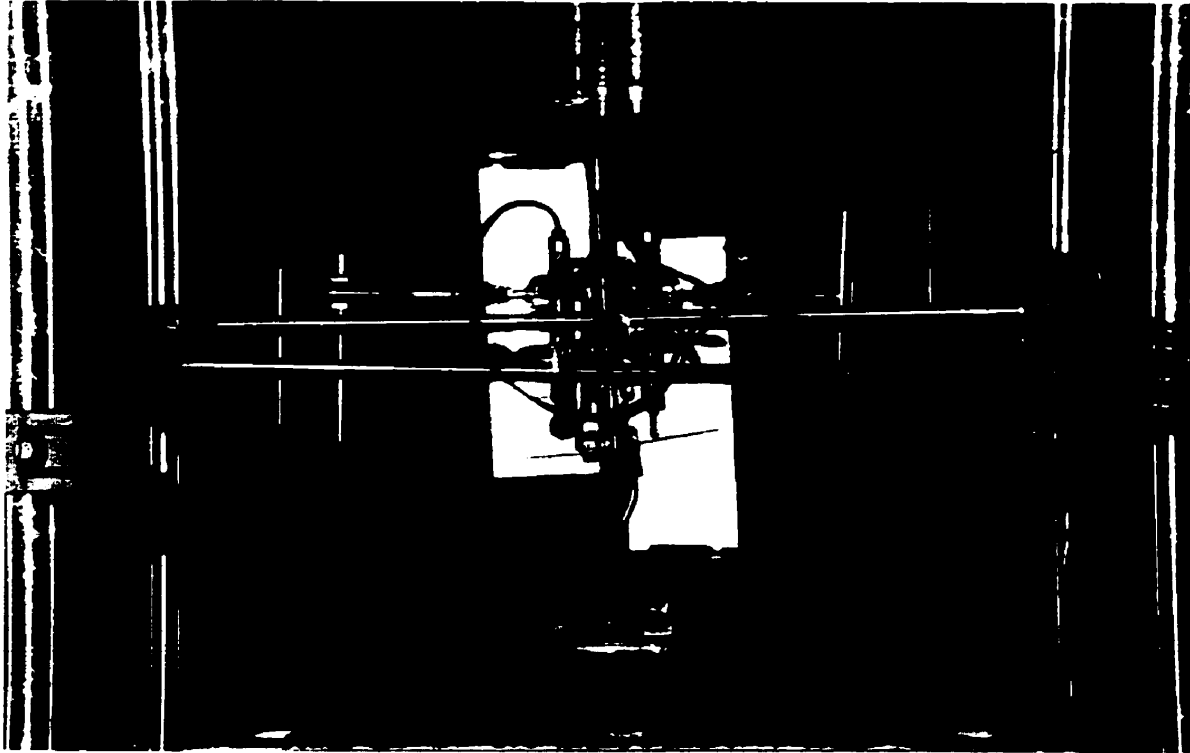


(a)



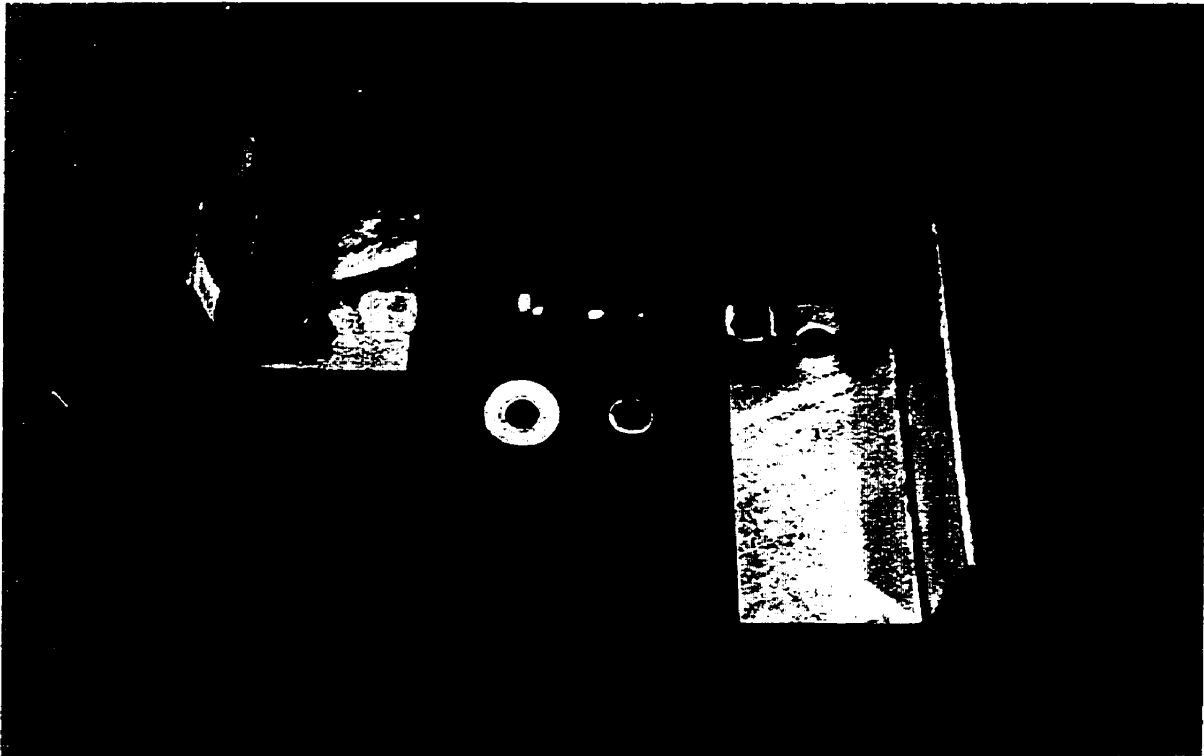
(b)

**Figure 4.39 Typical failure mode of specimens with 3 bolts (Test Series C)**

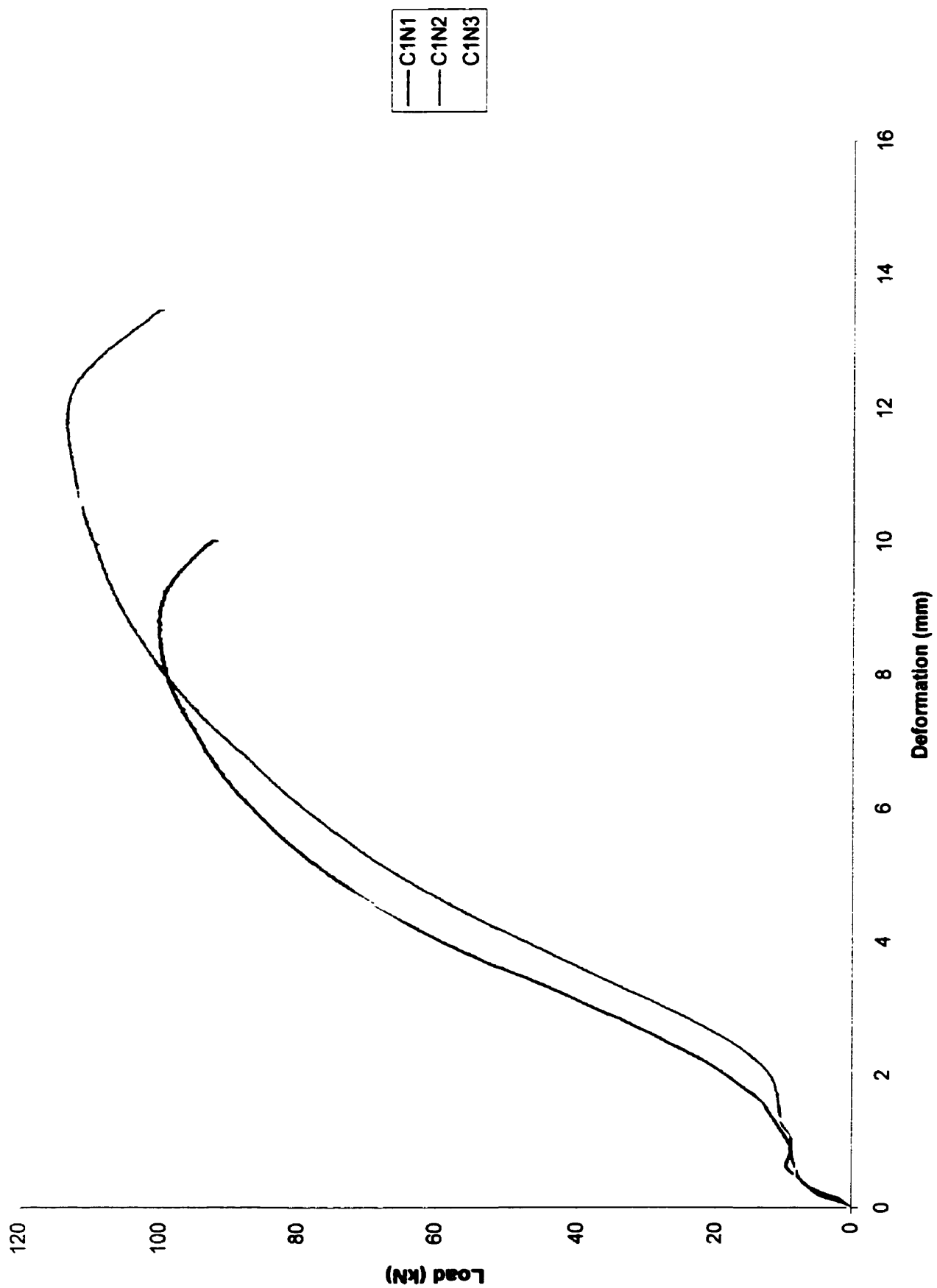


**Figure 4.40 Typical failure mode of specimens with 4 bolts (Test Series C)**

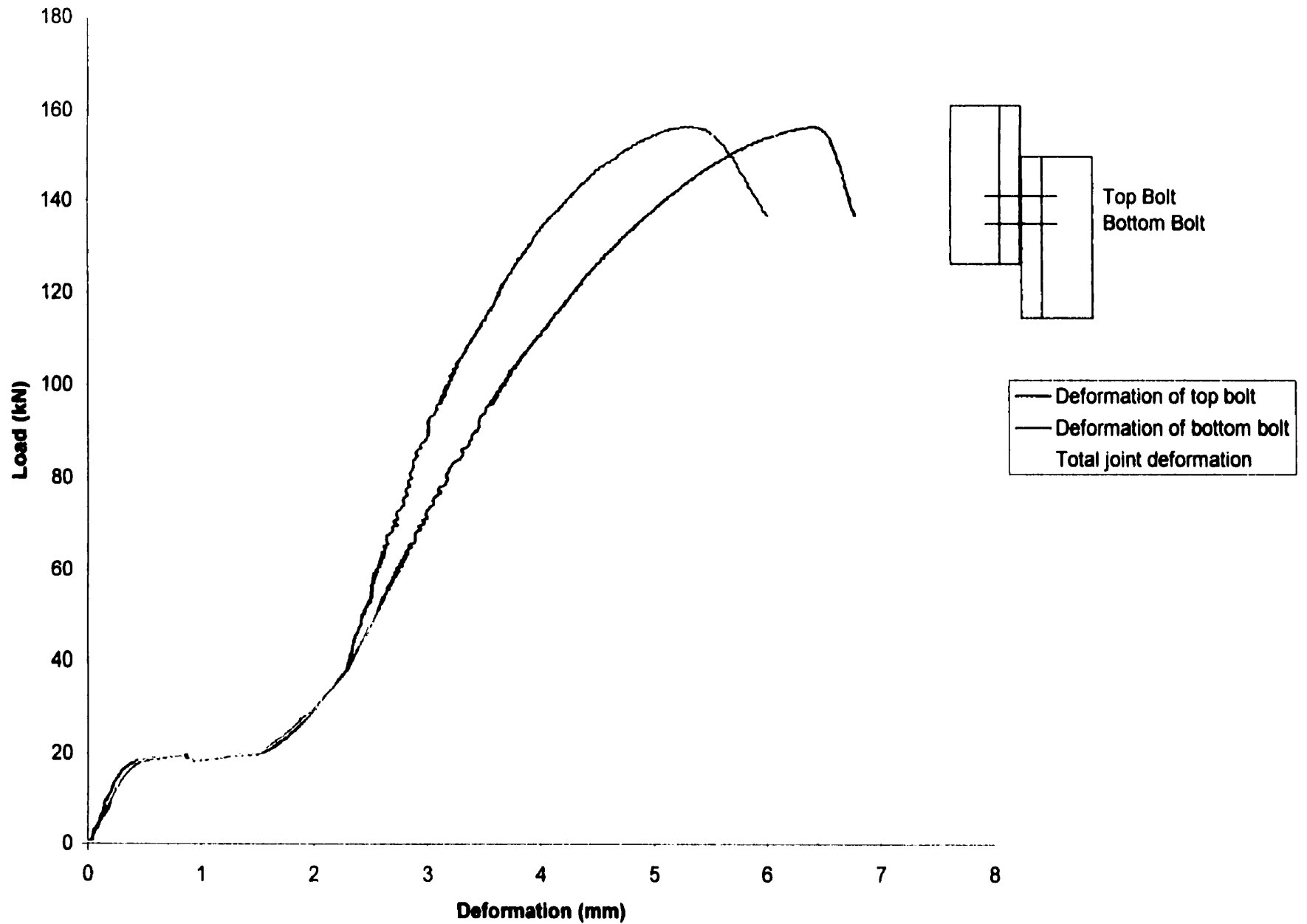




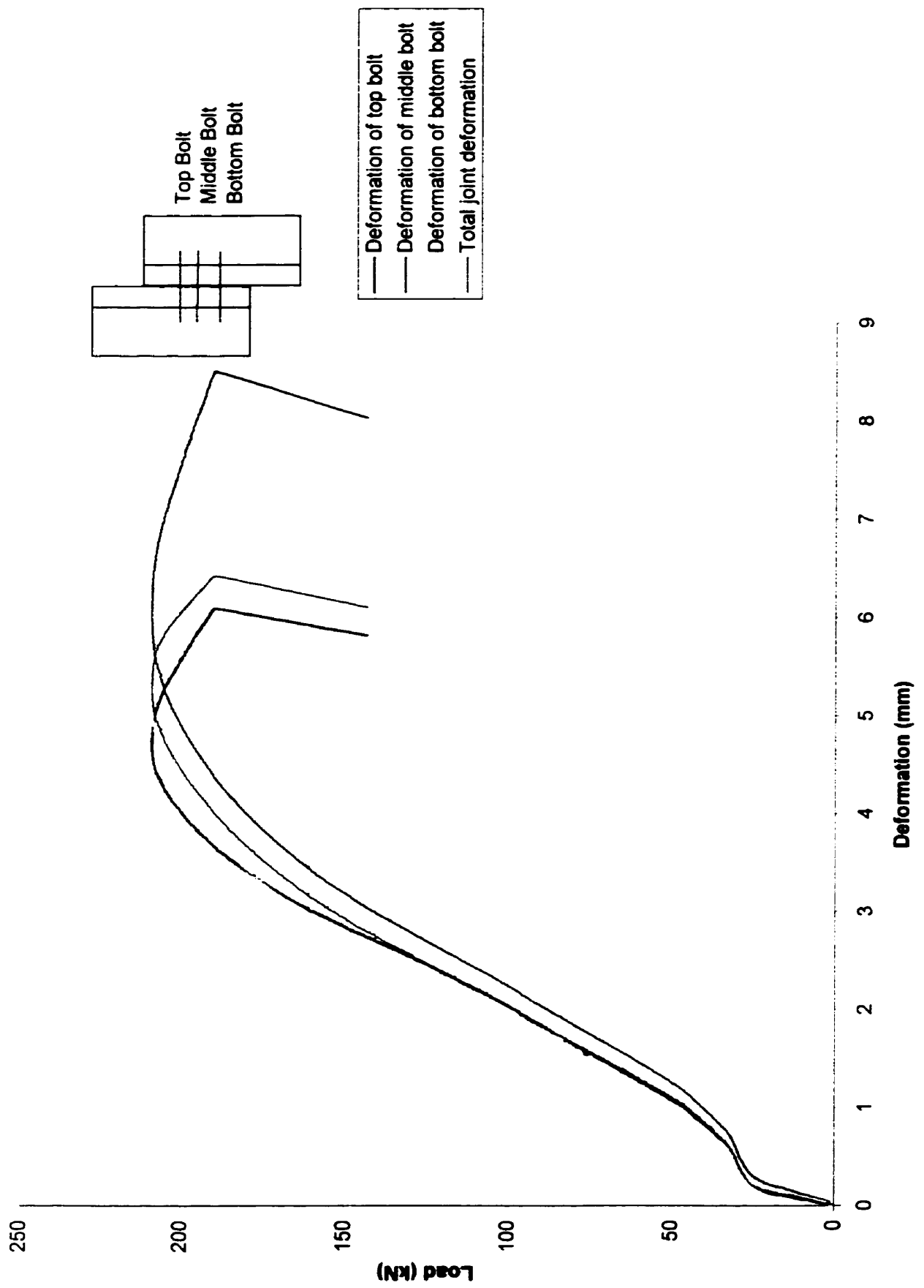
**Figure 4.41 Failure by bolt completely shearing apart in the re-tested specimen C1M1 (Test Series C)**



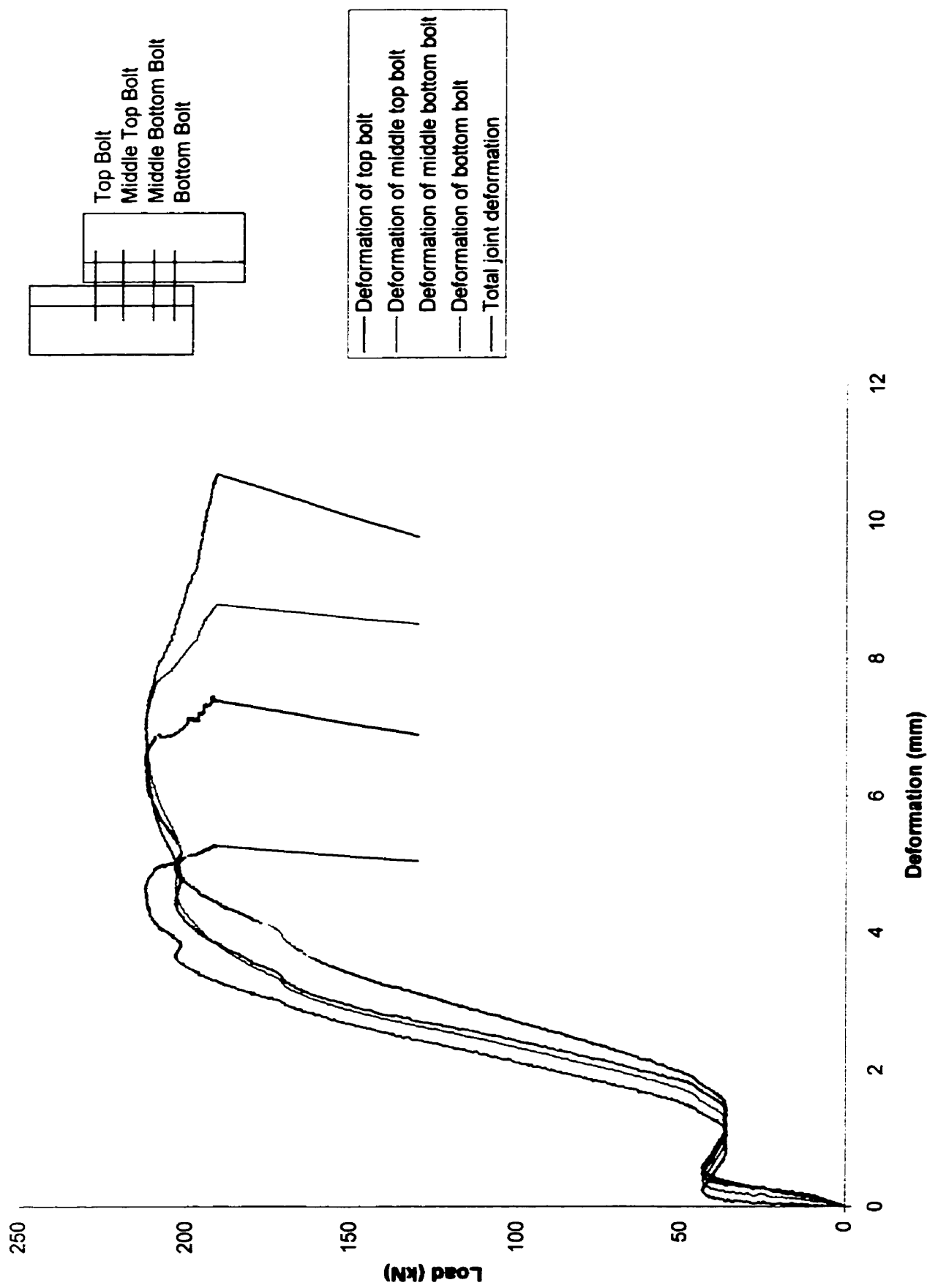
**Figure 4.42 Load versus total joint deformation diagrams for single bolted joints with normal construction clearance (1.59 mm) at assembly of Test Series C**



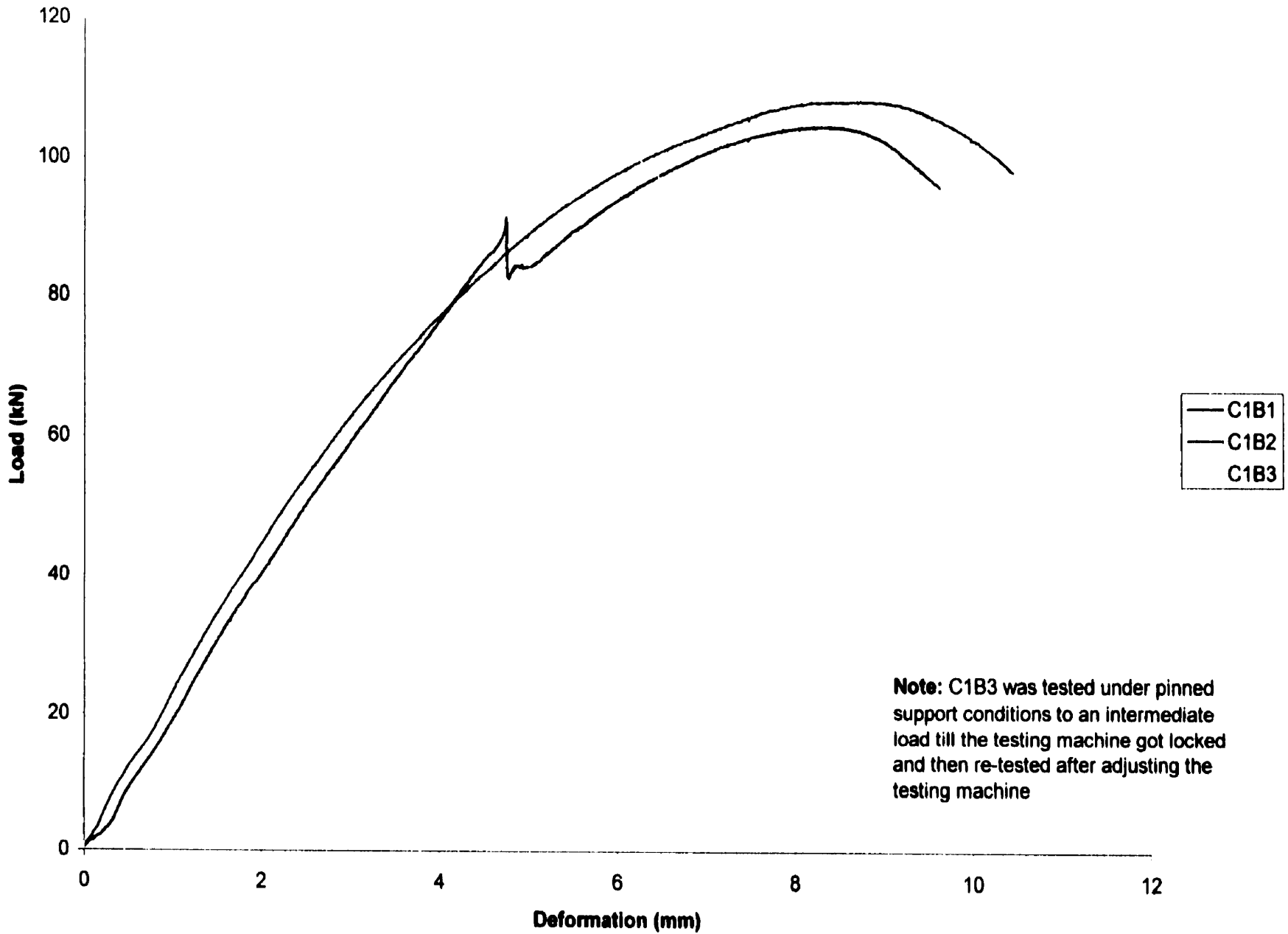
**Figure 4.43 Typical load versus bolt deformation diagrams for joints with two bolts and normal construction clearance (1.59 mm) at assembly of Test Series C (Specimen C2N1)**



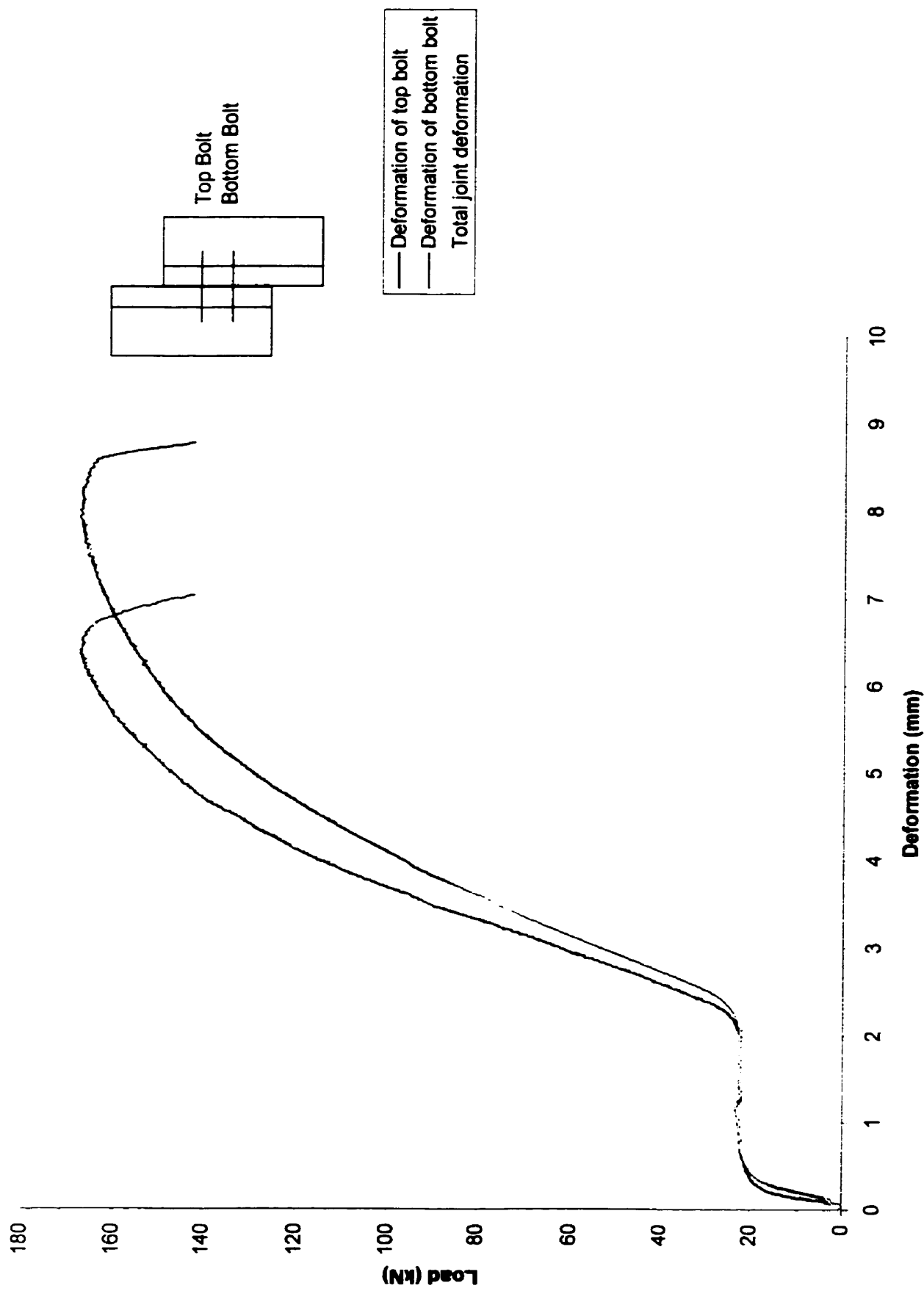
**Figure 4.44 Typical load versus bolt deformation diagrams for joints with three bolts and normal construction clearance (1.59 mm) at assembly of Test Series C (Specimen C3N2)**



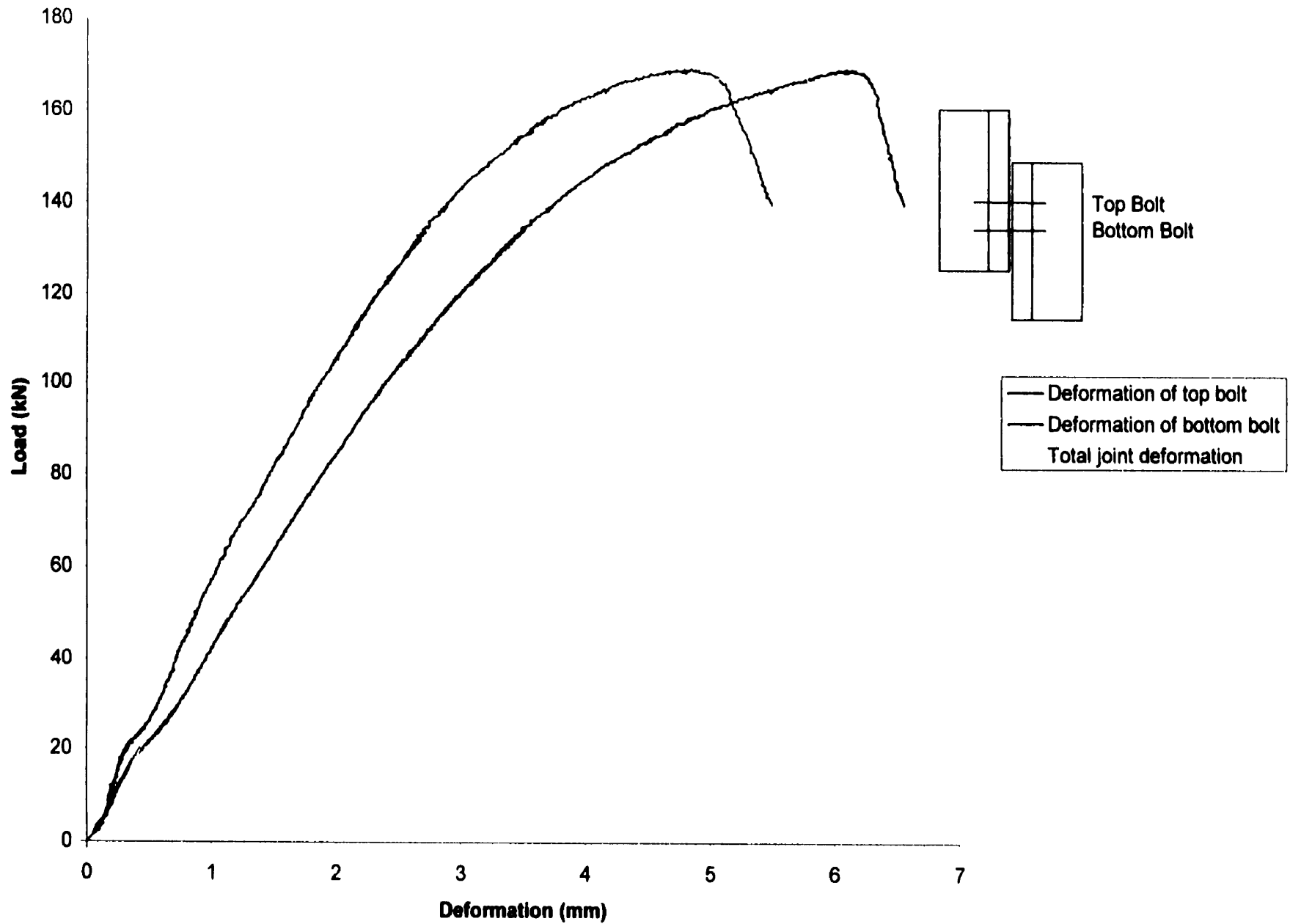
**Figure 4.45 Typical load versus bolt deformation diagrams for joints with four bolts and normal construction clearance (1.59 mm) at assembly of Test Series C (Specimen C4N3)**



**Figure 4.46 Load versus total joint deformation diagrams for single bolted joints set in bearing at assembly of Test Series C**

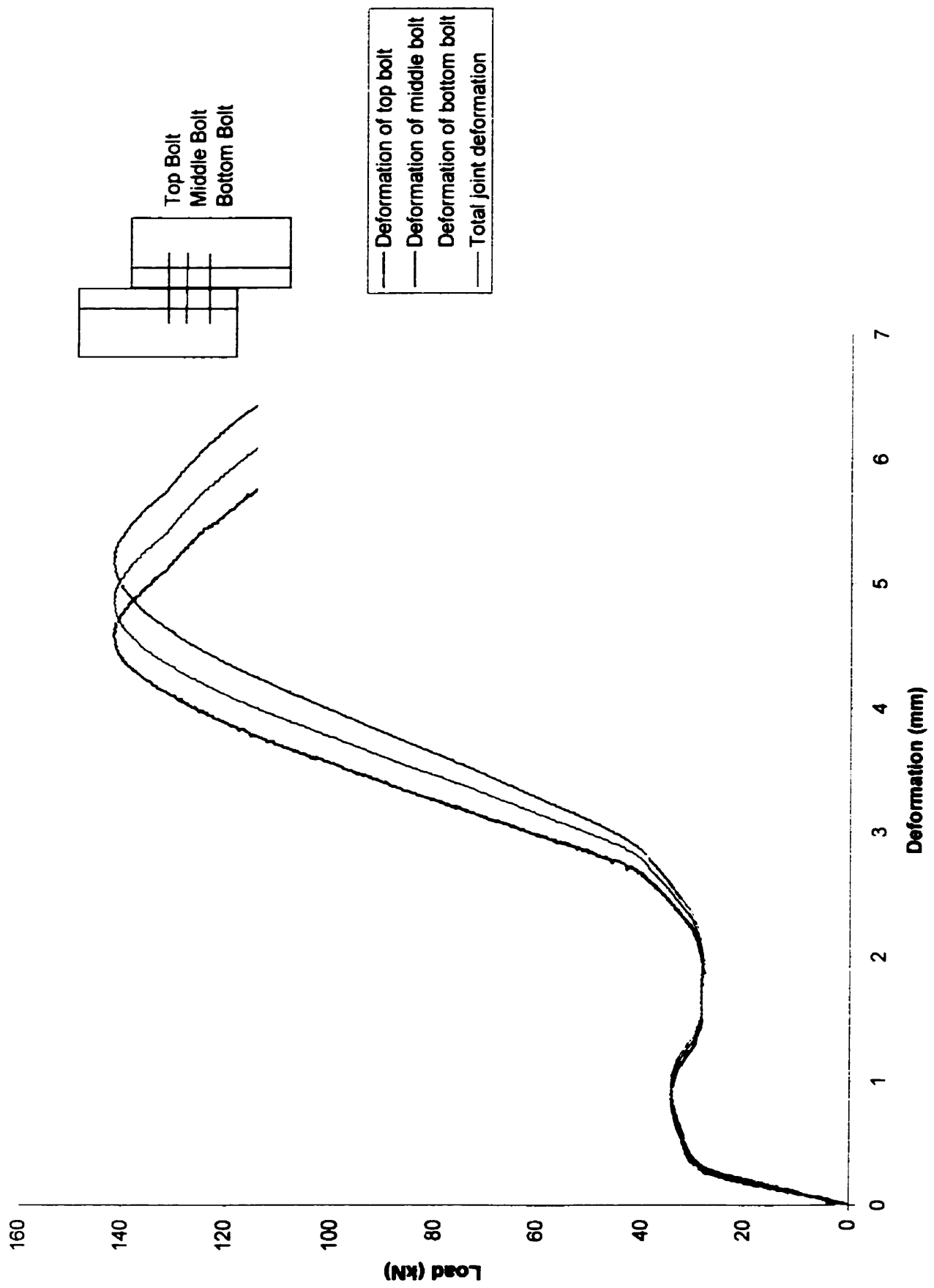


**Figure 4.47 Typical load versus bolt deformation diagrams for joints with two bolts and maximum construction clearance (3.18 mm) at assembly of Test Series C (Specimen C2M2)**

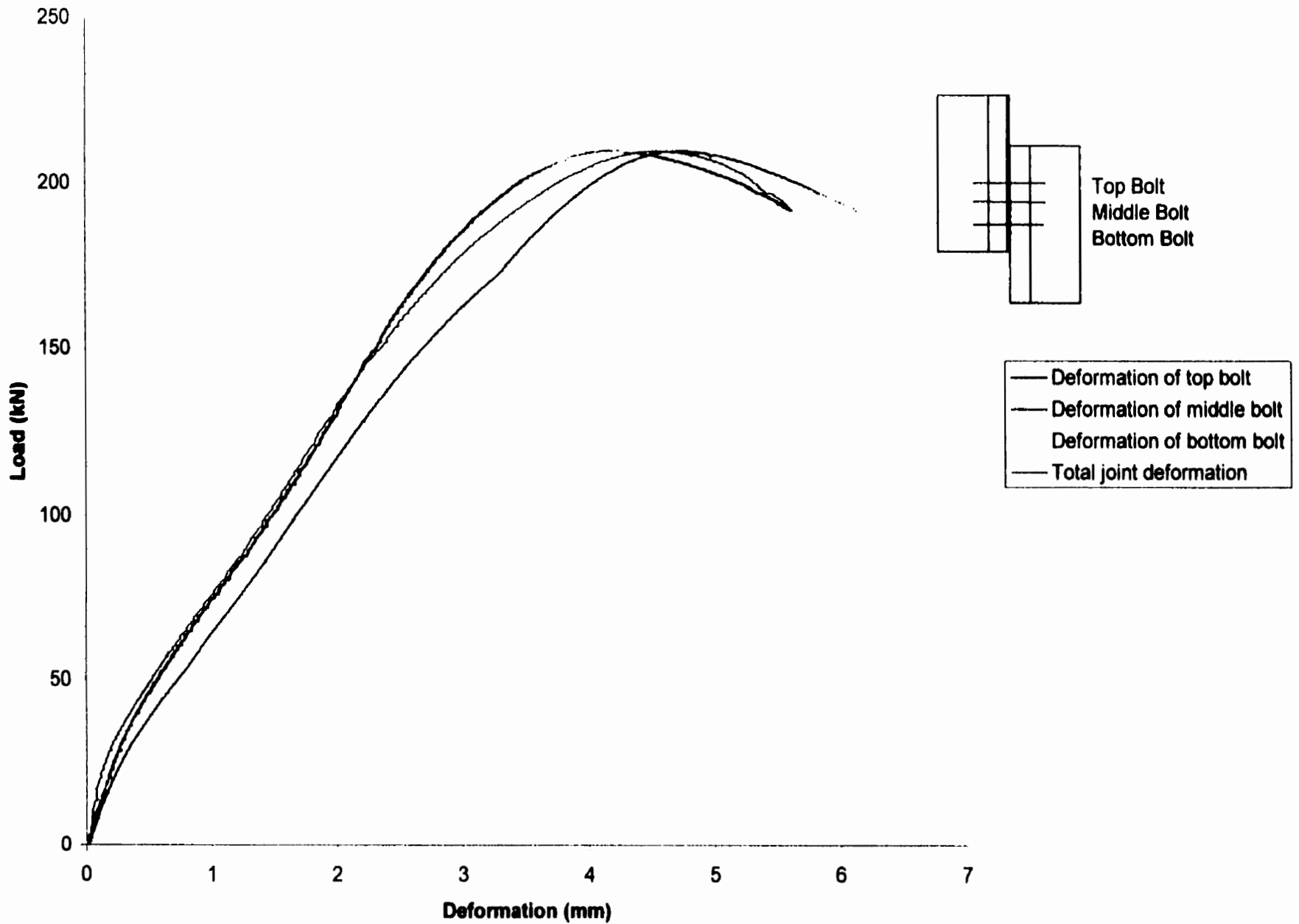


**Figure 4.48 Typical load versus bolt deformation diagrams for joints with two bolts set in bearing at assembly of Test Series C (Specimen C2B3)**

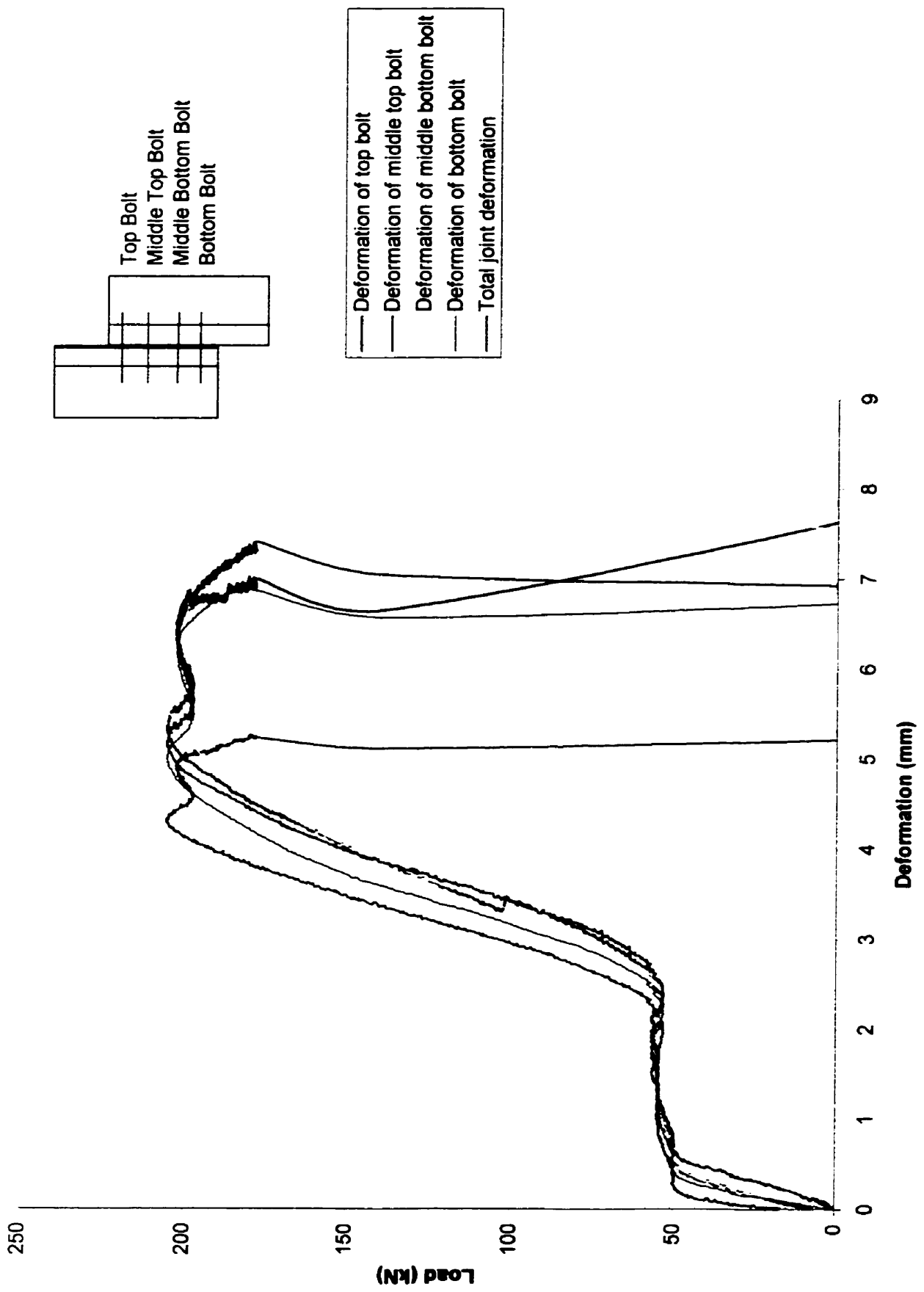




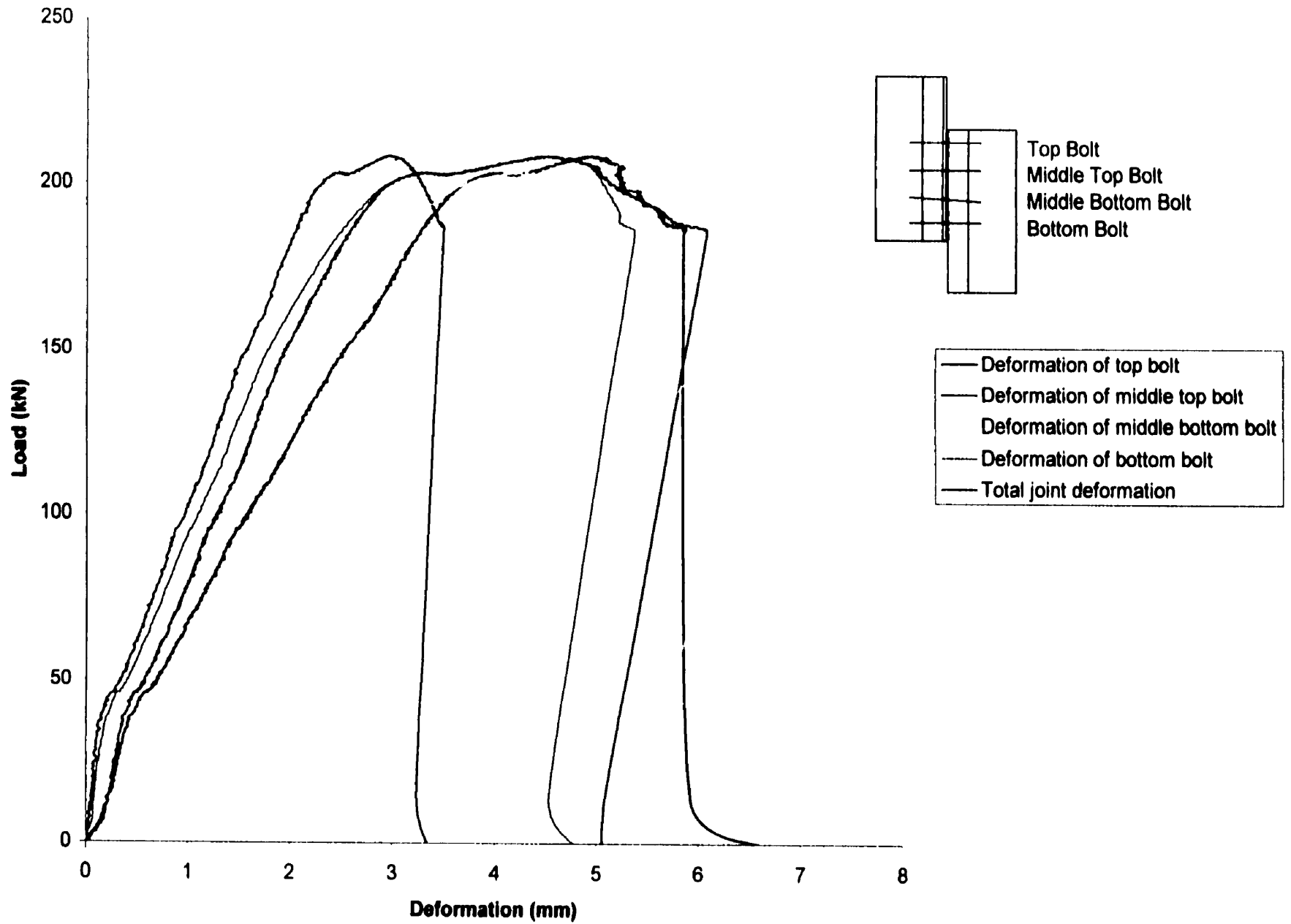
**Figure 4.49 Typical load versus bolt deformation diagrams for joints with three bolts and maximum construction clearance (3.18 mm) at assembly of Test Series C (Specimen C3M1)**



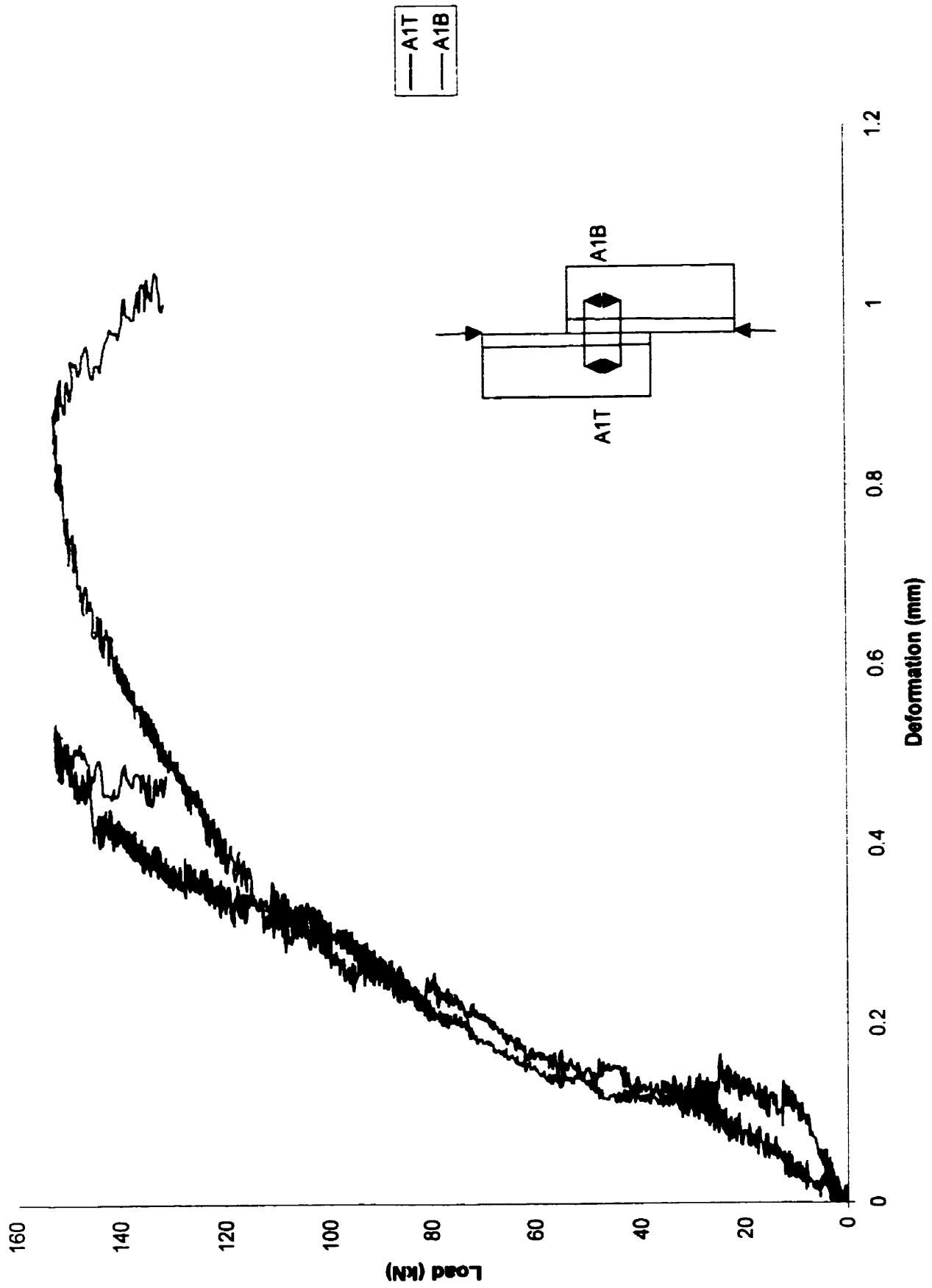
**Figure 4.50 Typical load versus bolt deformation diagrams for joints with three bolts set in bearing at assembly of Test Series C (Specimen C3B1)**



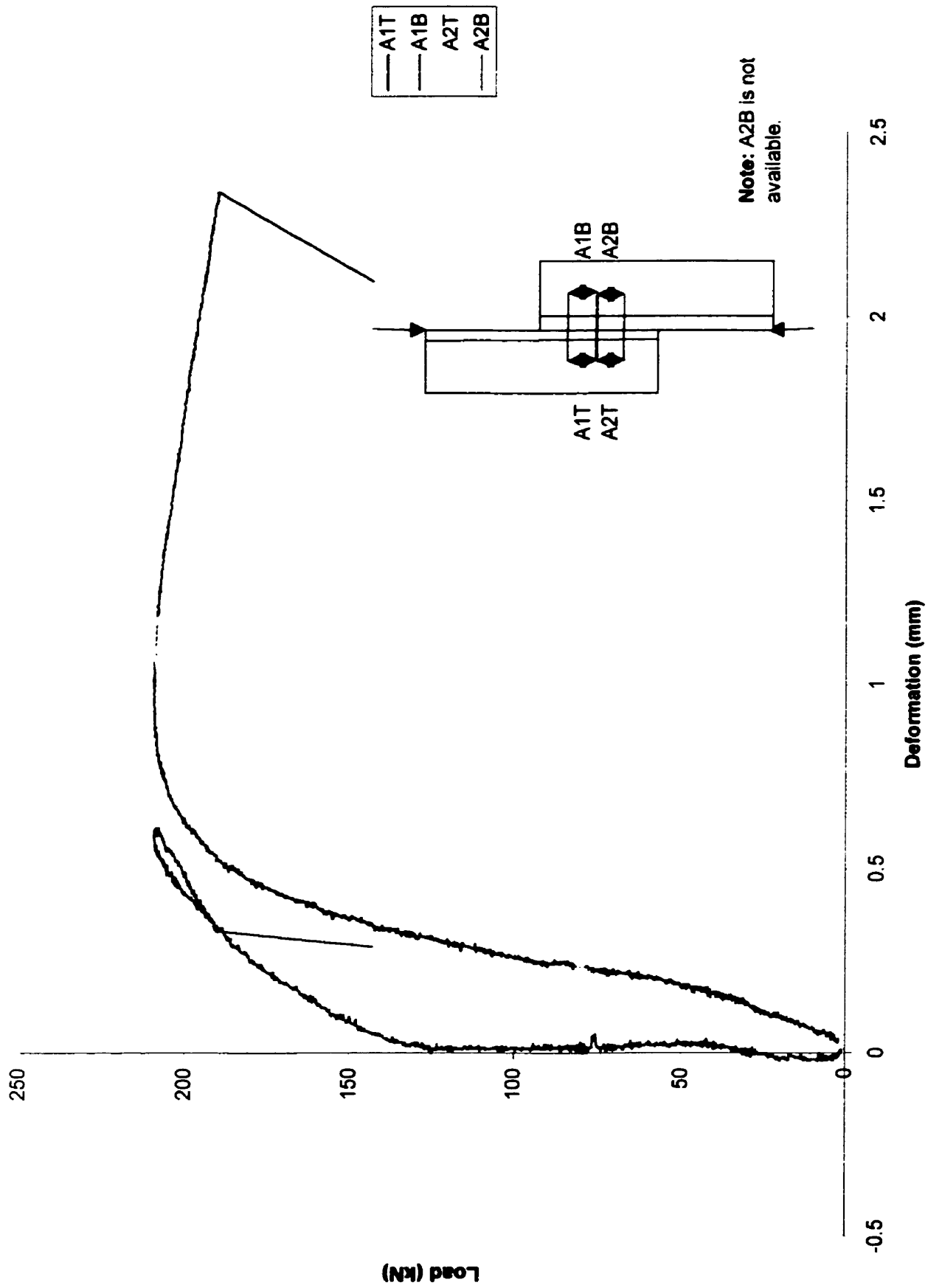
**Figure 4.51 Typical load versus bolt deformation diagrams for joints with four bolts and maximum construction clearance (3.18 mm) at assembly of Test Series C (Specimen C4M3)**



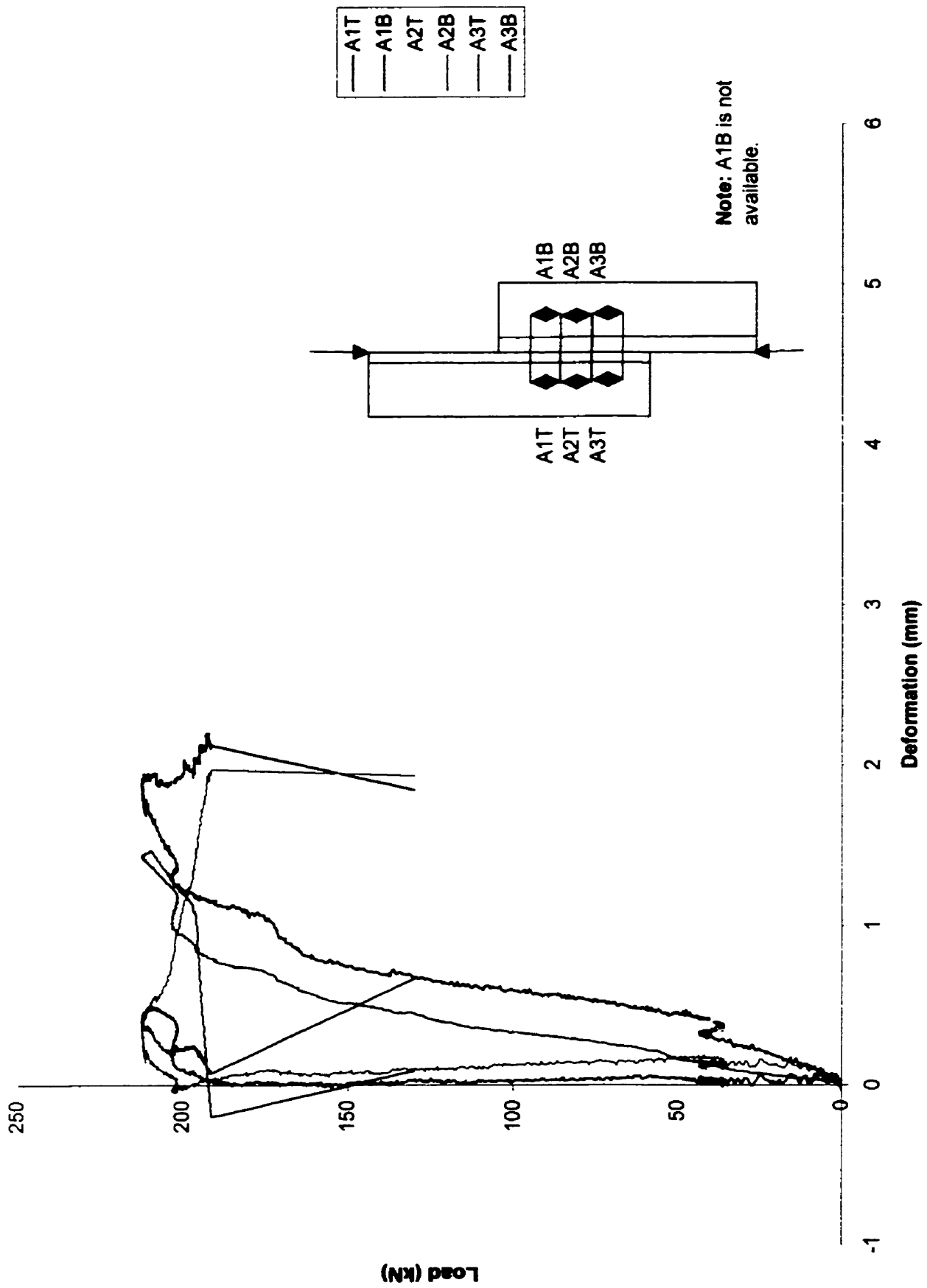
**Figure 4.52 Typical load versus bolt deformation diagrams for joints with four bolts set in bearing at assembly of Test Series C (Specimen C4B2)**



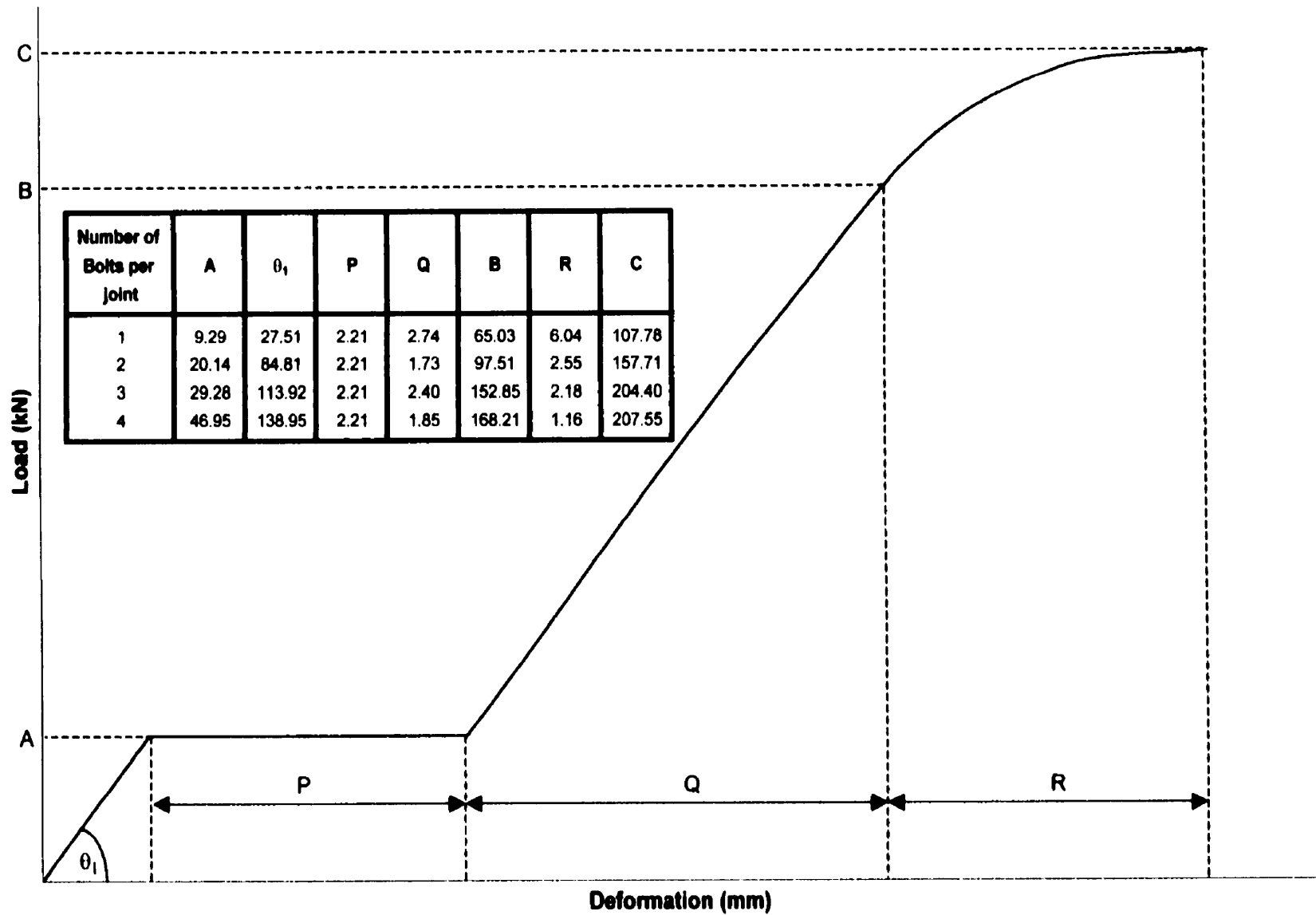
**Figure 4.53 Typical variations of load and deformation between bolt holes in the angle sections of joints with two bolts (Specimen C2B2)**



**Figure 4.54 Typical variations of load and deformation between bolt holes in the angle sections of joints with three bolts (Specimen C3N2)**

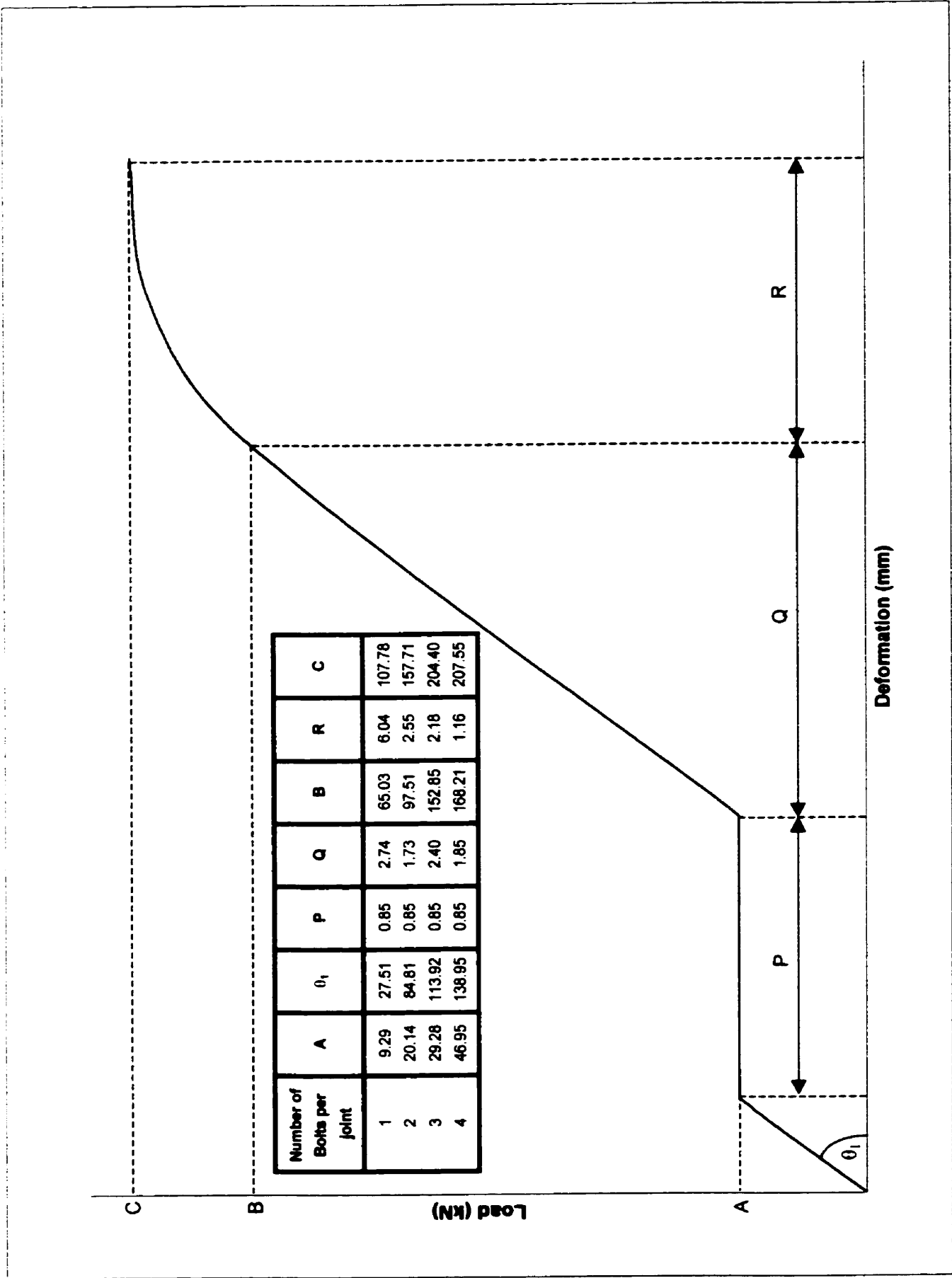


**Figure 4.55 Typical variations of load and deformation between bolt holes in the angle sections of joints with four bolts (Specimen C4N3)**

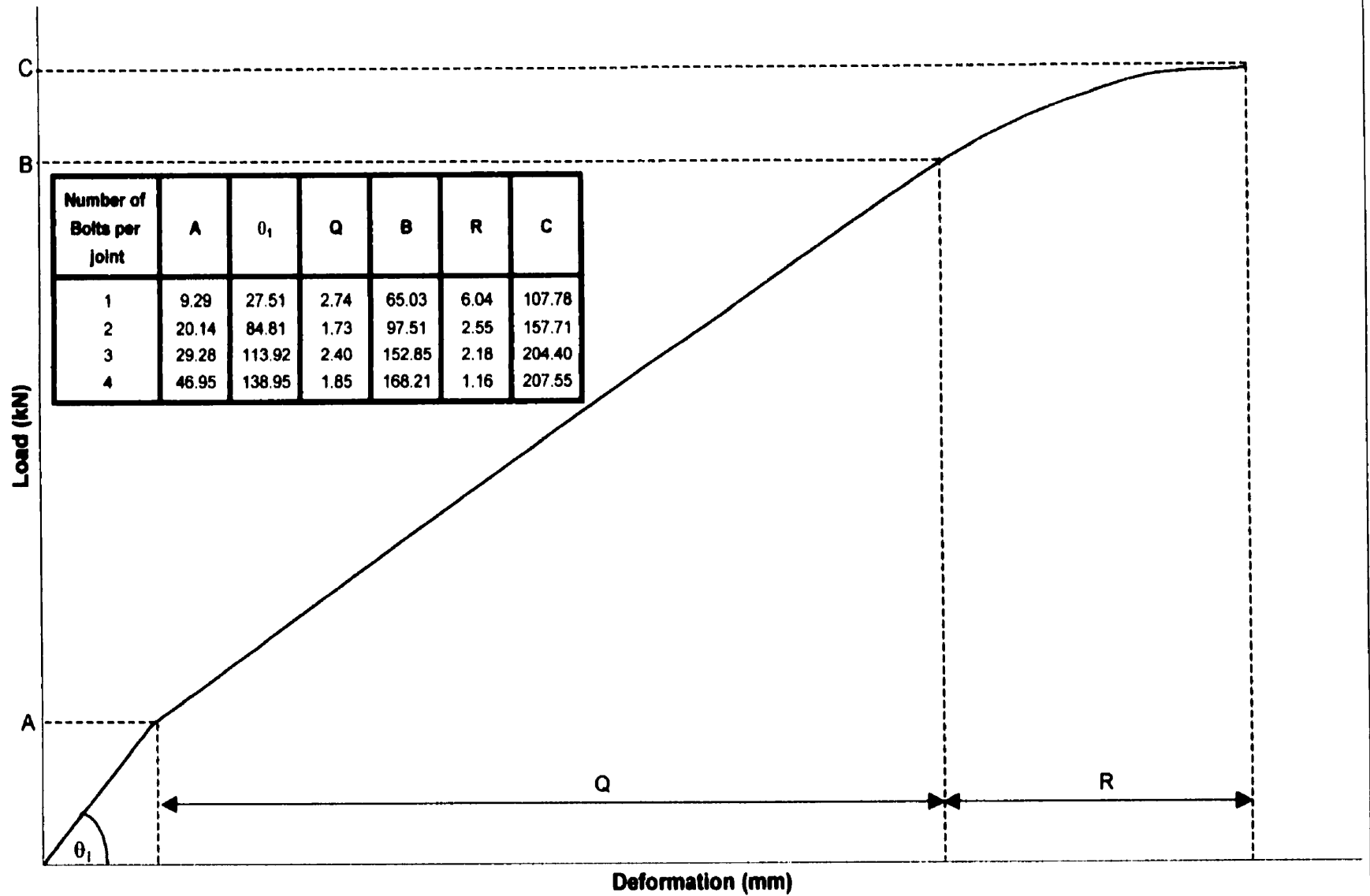


**Figure 4.56 Idealized load versus deformation diagram for joints with maximum construction clearance at assembly of Test Series C**





**Figure 4.57 Idealized load versus deformation diagram for joints with normal construction clearance at assembly of Test Series C**



**Figure 4.58** Idealized load versus deformation diagram for joints set in bearing at assembly of Test Series C

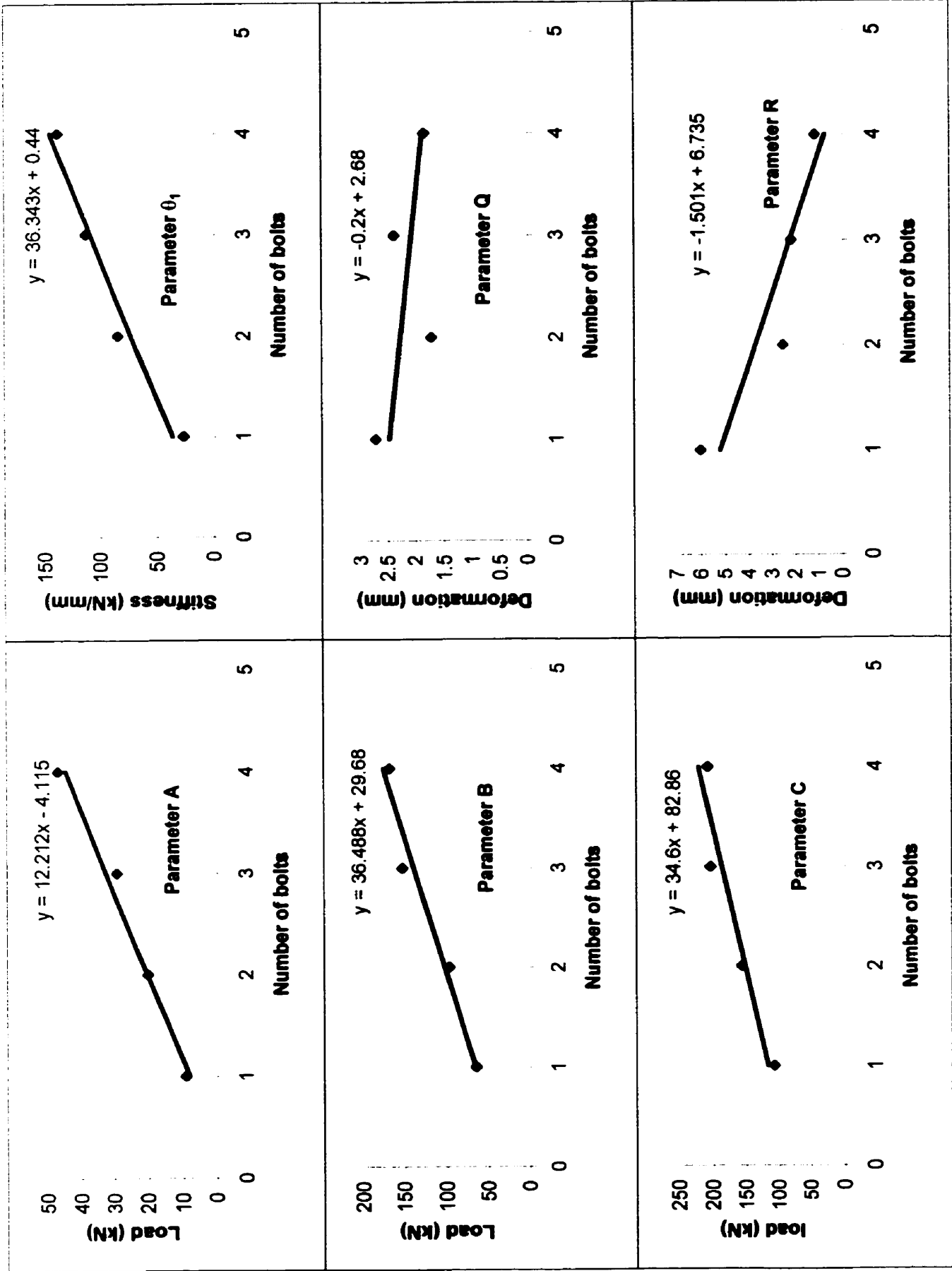


Figure 4.59 Variations of governing parameters with number of bolts

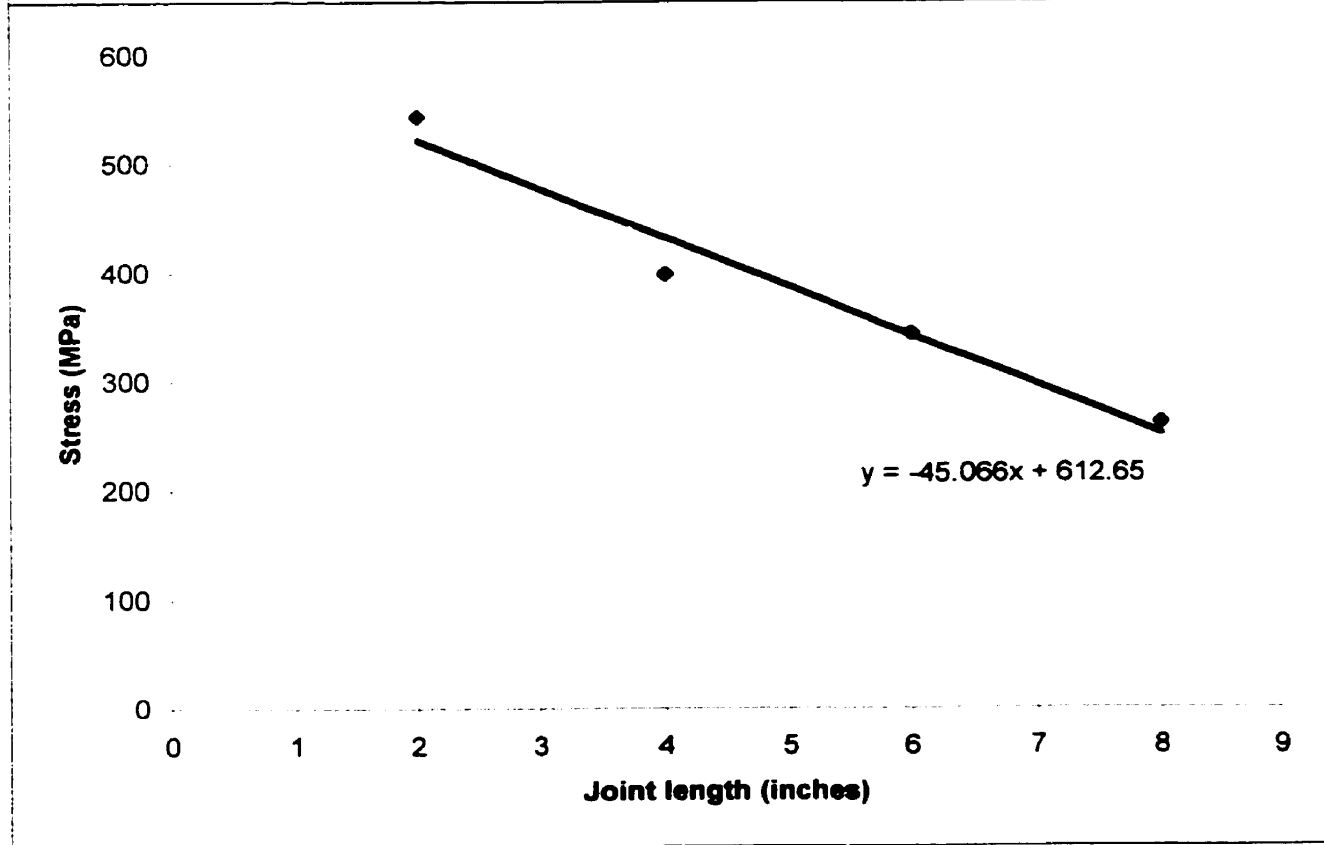
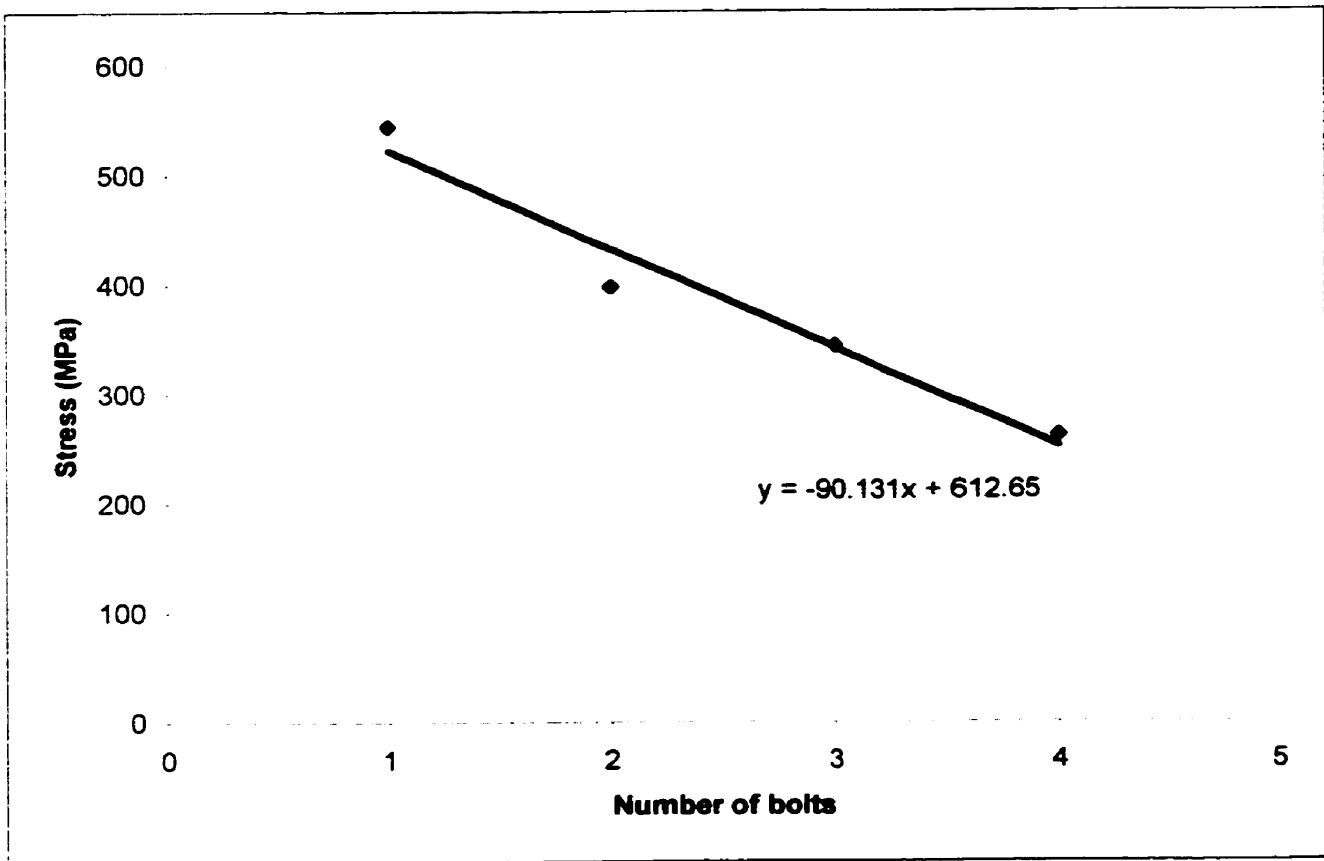


Figure 4.60 Variations of shear strength with number of bolts and joint length

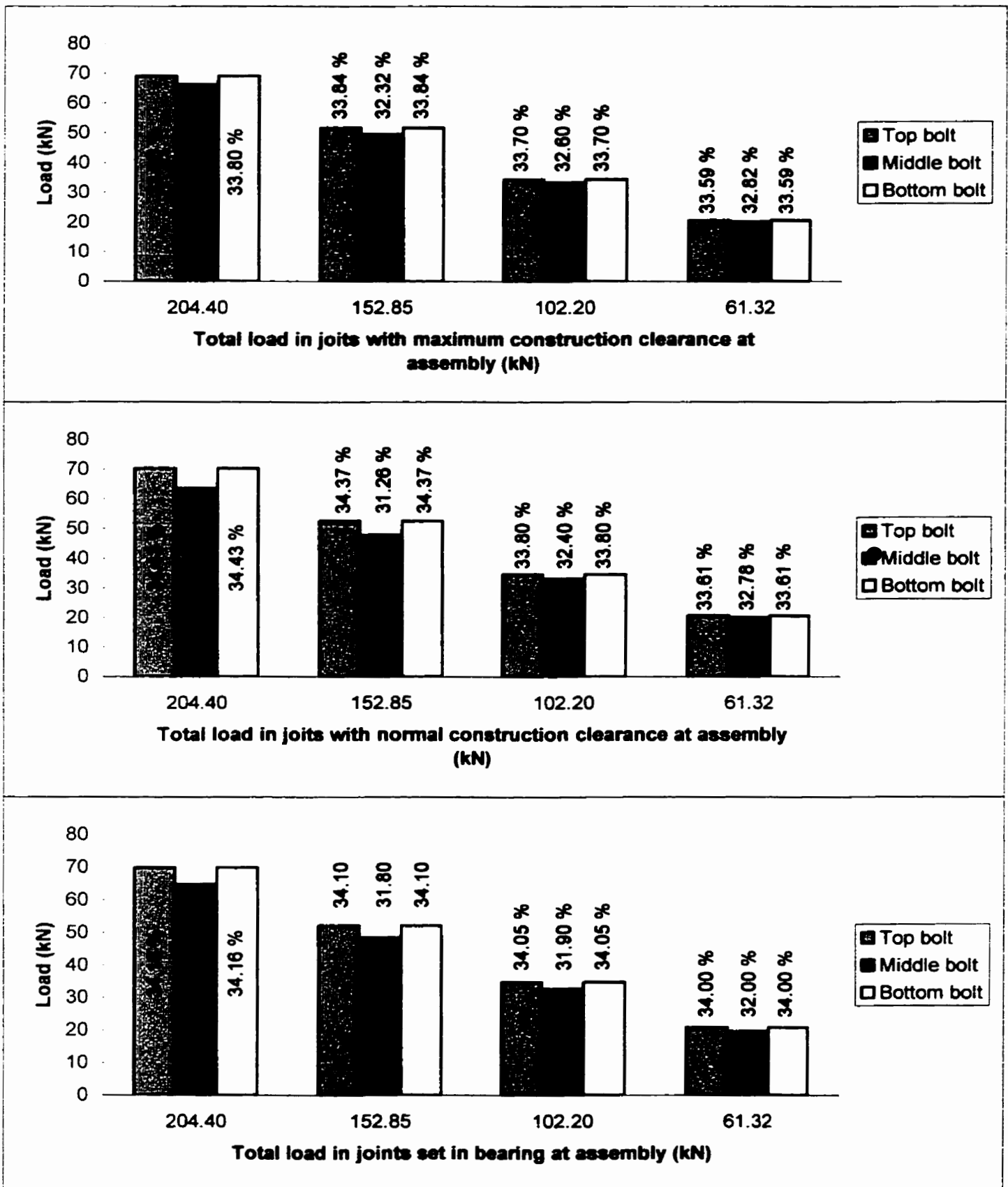


Figure 4.61 Percentage load on each bolt of three-bolt joints at ultimate load, at onset of plasticity, 50 percent of ultimate load, and 30 percent of ultimate load

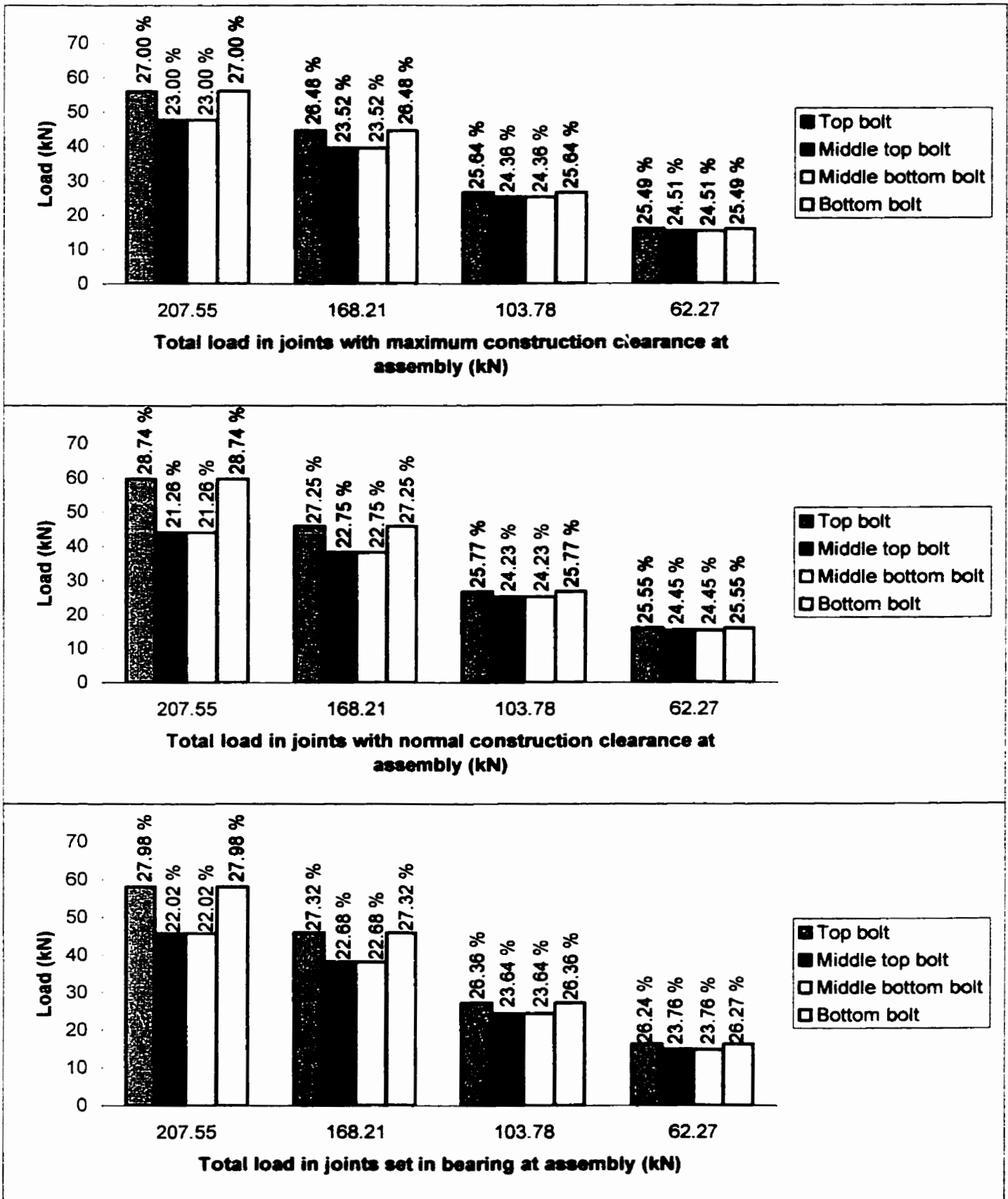
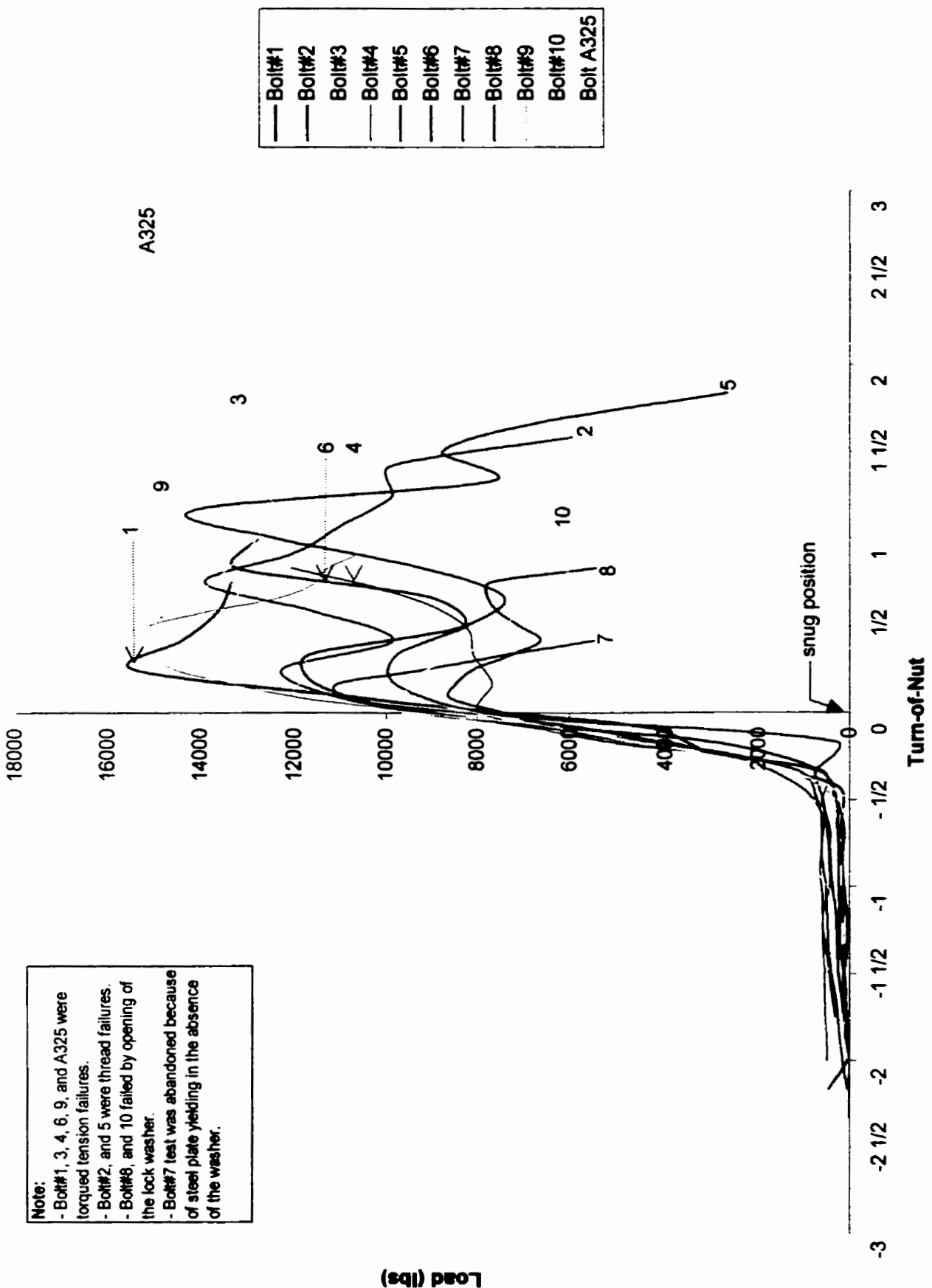


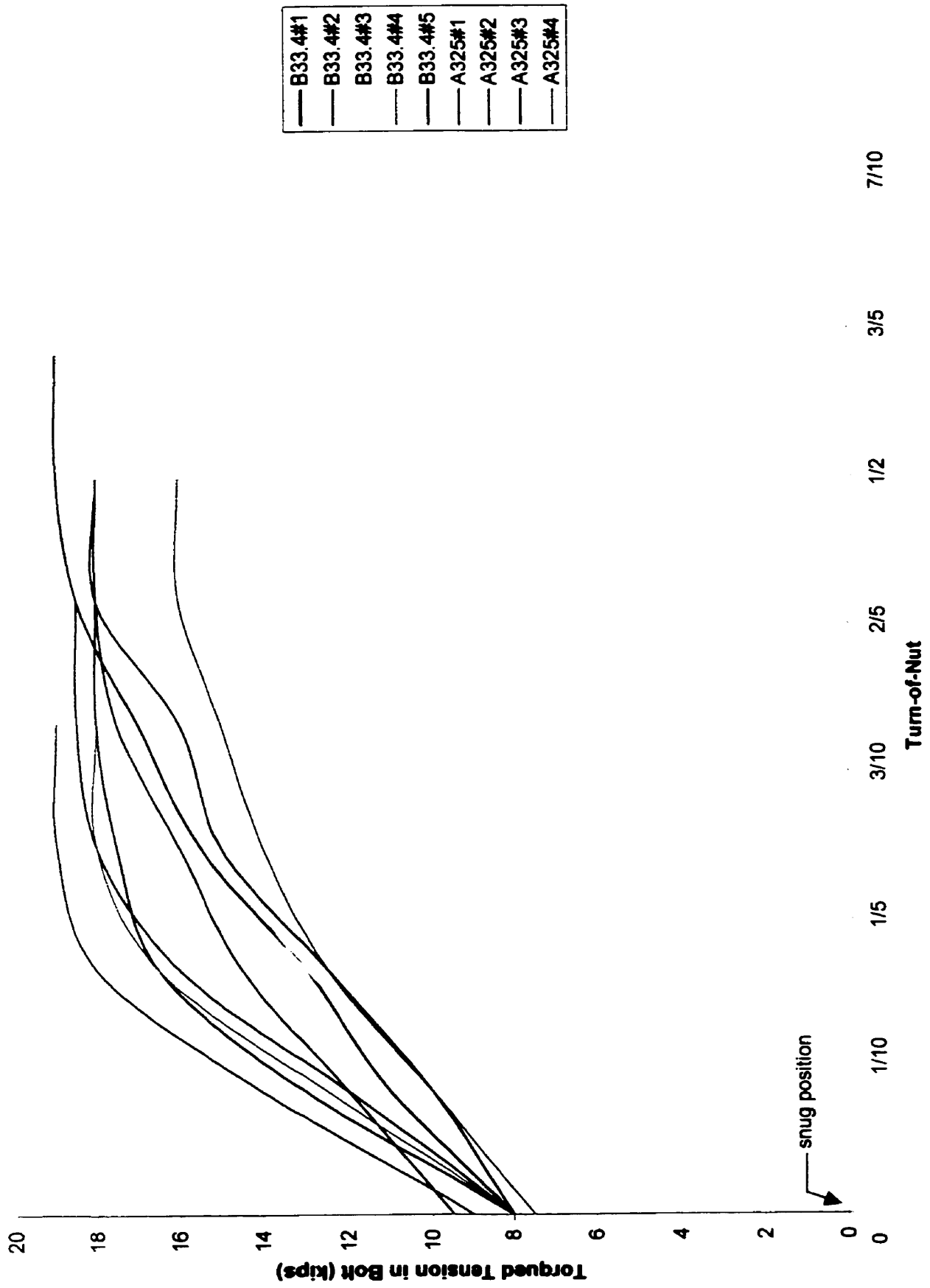
Figure 4.62 Percentage load on each bolt of four-bolt joints at ultimate load, at onset of plasticity, 50 percent of ultimate load, and 30 percent of ultimate load



**Note:**

- Bolt#1, 3, 4, 6, 9, and A325 were torqued tension failures.
- Bolt#2, and 5 were thread failures.
- Bolt#6, and 10 failed by opening of the lock washer.
- Bolt#7 test was abandoned because of steel plate yielding in the absence of the washer.

**Figure 4.63** Variation of tension versus turn-of-nut in torqued tension tests using the special rig

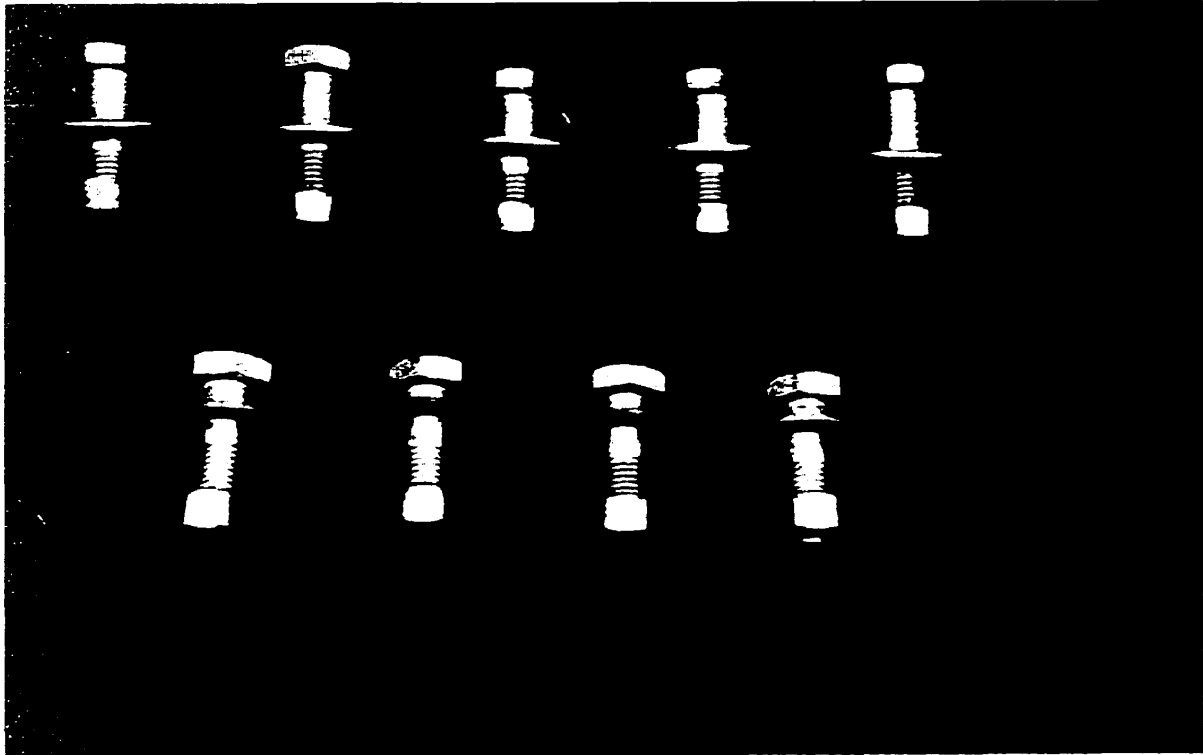


**Figure 4.64** Variation of tension versus turn-of-nut in torqued tension tests using the Skidmore-Wilhelm Hydraulic Bolt Calibrator





**Figure 4.65 Failure modes of bolts tensioned by turn-of-nut method using the special rig**



**Figure 4.66 Bolts close to failure when tensioned by turn-of-nut method using Skidmore-Wilhelm Hydraulic Bolt Calibrator**

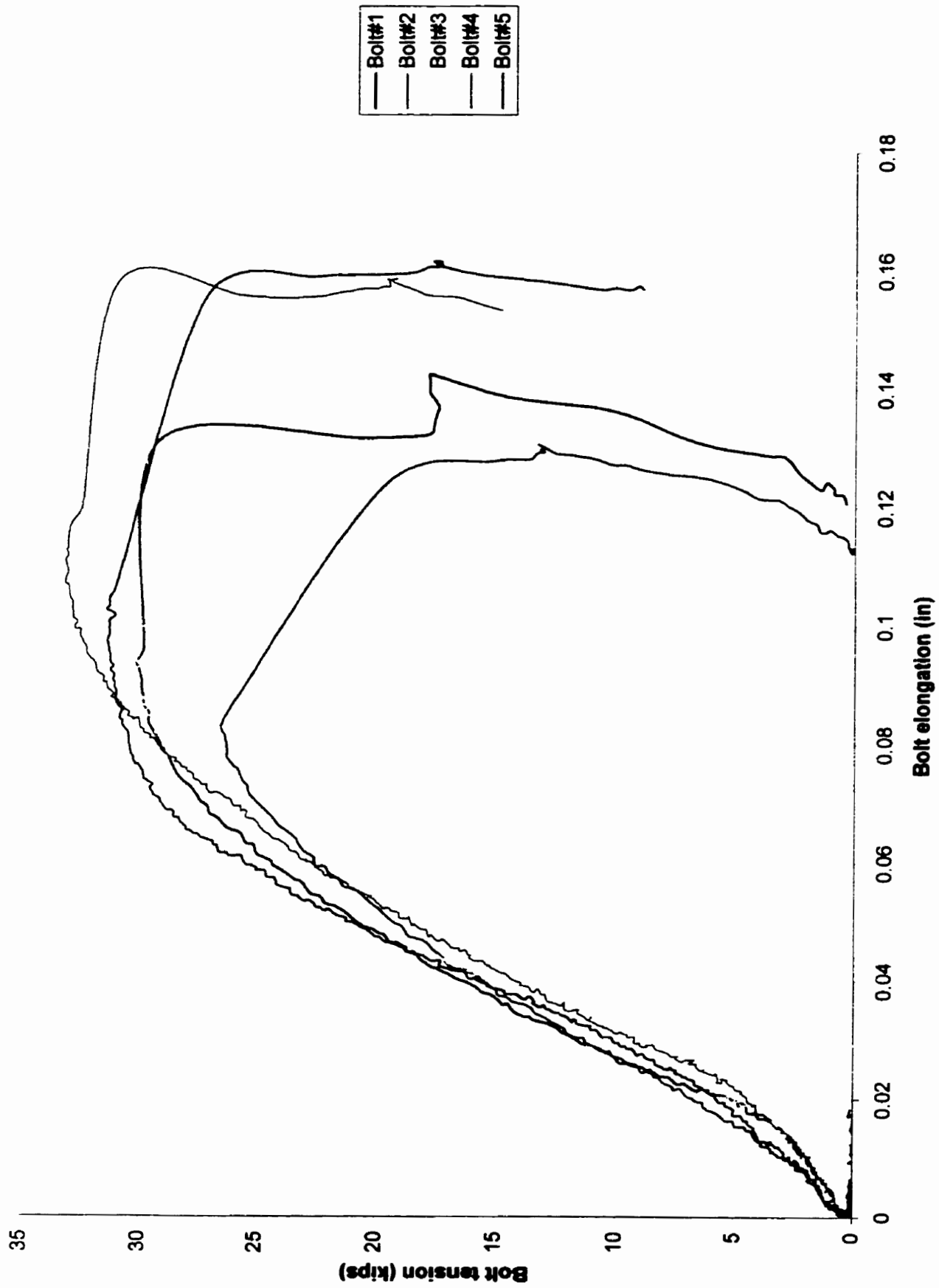


Figure 4.67 Load versus elongation diagrams of B33.4 grade 5 bolts tested in direct tension

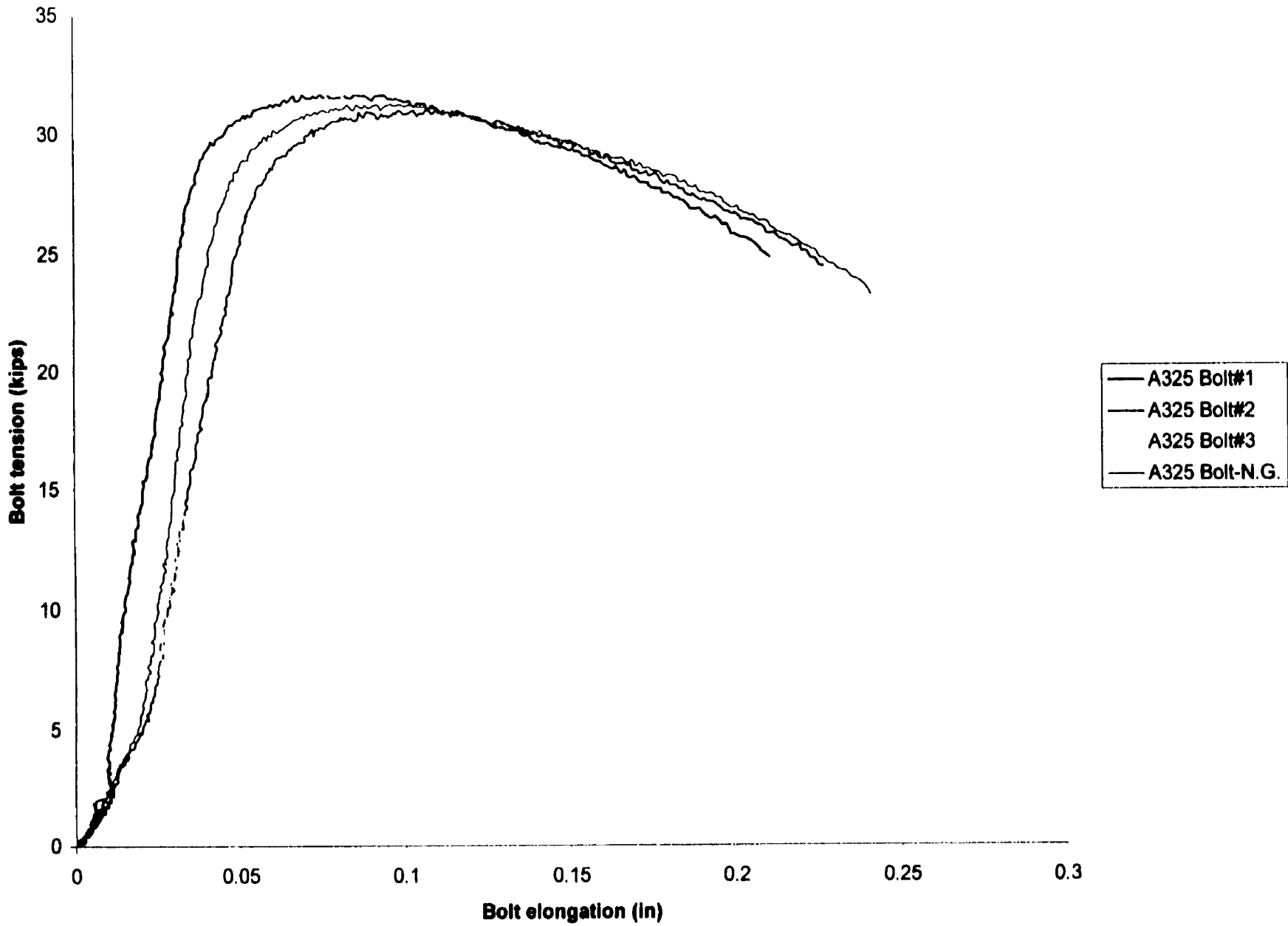
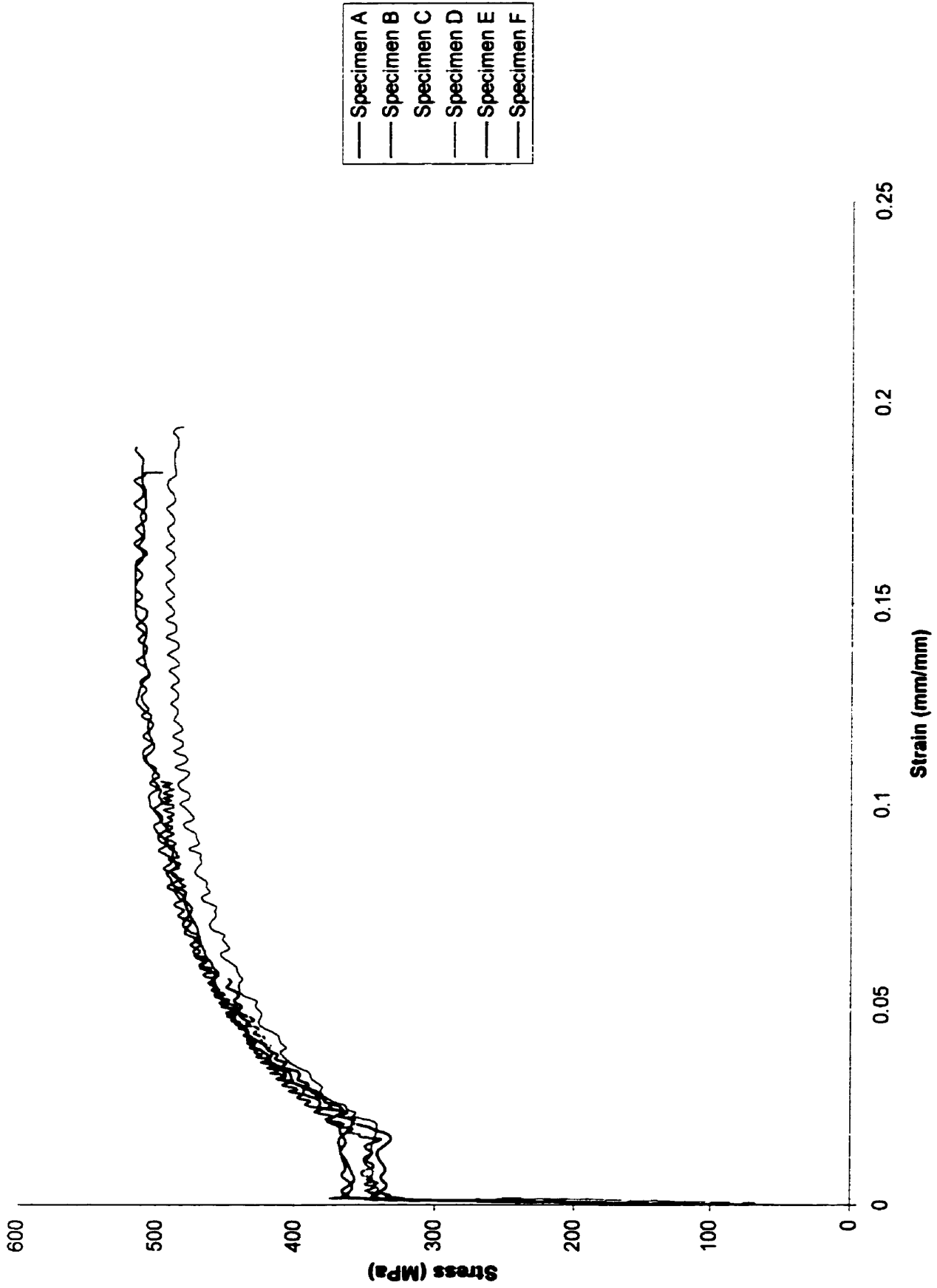


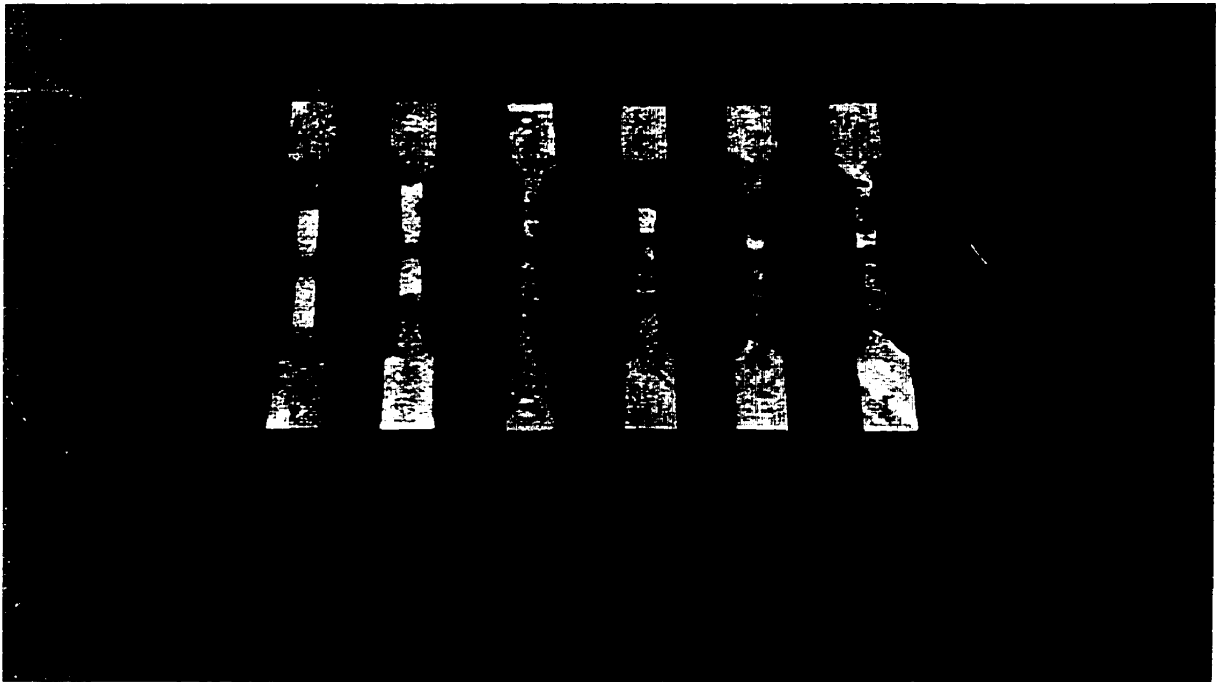
Figure 4.68 Load versus elongation diagrams of A325 bolts tested in direct tension



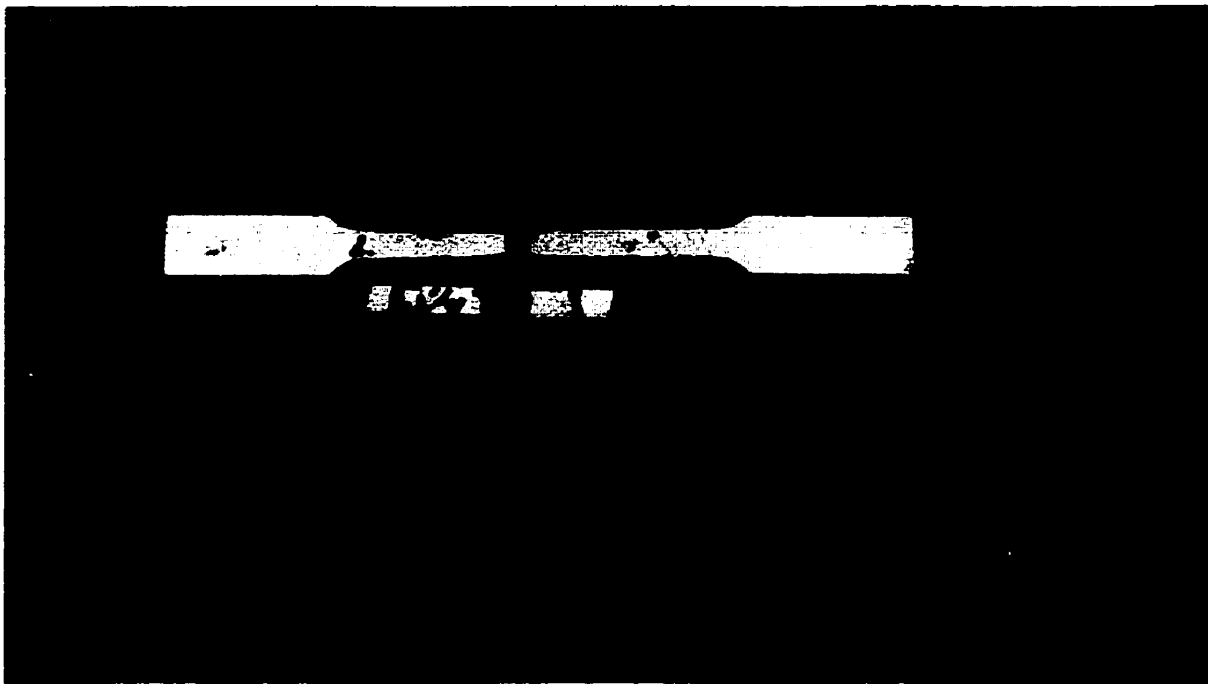
**Figure 4.69 Two failure modes of direct tension tests on bolts**



**Figure 4.70 Stress versus strain diagrams of tension test coupons from steel angles**



(a)



(b)

**Figure 4.71 Tension test coupons from steel angles after failure and a close up of a typical specimen with galvanizing layer peeled off**